

Your Guide to the City of Solana Beach Sign Permit Application

This is a guide designed to assist you in completing the City of Solana Beach sign permit application. You need only complete the SHADED portions. Our experience is that the more complete and accurate an application is, the more quickly it progresses through the review and approval process. With that in mind, please read the following guidelines and tips, we trust they will be of value. You are encouraged to review the entire Comprehensive Sign Code (Chapter 17.64). It can be viewed on the City's web site (www.ci.solana-beach.ca.us) or you are welcome to visit us at 635 South Highway 101, or give us a call at (858) 720-2440 to pick up a copy. Please let us know if we may be of further assistance. Finally, *Thank You* for choosing Solana Beach for your enterprise; we wish you all the best, and continued success.

"A.P.N." IS THE ASSESSOR'S PARCEL NUMBER

THIS IS THE OWNER OF THE BUILDING.

INCLUDE BUSINESS NAME.

THE "CONTRACTOR" IS USUALLY THE SIGN COMPANY.

THE CONTACT PERSON NAME AND PHONE NUMBER IS **VERY IMPORTANT!** THIS IS THE PERSON WHO WILL BE CONTACTED TO PICK UP THE PERMIT.

ONLY LIST THE OLD SIGNS THAT WILL REMAIN AFTER YOU'RE FINISHED.

COMPLETE ONE OF THESE SECTIONS FOR EACH SIGN. **SEE PAGE 2** FOR A LIST OF COMMON SIGN TYPES.

DESIGNATE EACH SIGN WITH A NUMBER, THEN USE THAT SAME NUMBER ON YOUR PLANS.

PLEASE SIGN AND DATE THE APPLICATION.



CITY OF SOLANA BEACH SIGN PERMIT APPLICATION

(APPLICANT: COMPLETE SHADED AREA ONLY)

"SIGN COPY" IS THE MESSAGE ON THE SIGN.

PROPERTY OWNER	Address:	Suite:	Sign No.	Sign Type:	Project over R.O.W.? YES / NO
	A.P.N.:		Sign Area:	Freestanding Sign Hgt.:	
BUSINESS/OWNER	Name:	Phone:	Sign Copy (Lettering):	FEE:	
	Address:				
CONTRACTOR/AGENT	City:	Zip Code:	Sign No.	Sign Type:	Project over R.O.W.? YES / NO
	Name (Owner):		Sign Area:	s.f. Freestanding Sign Hgt.:	
CONTACT PERSON:	Address:		Sign Copy (Lettering):	FEE:	
	City:	Code:			
Name:		State License No.:	License Class:		
Address:					
City:					
State License No.:		License Class:			
Phone:					
Phone:					
EXISTING SIGNAGE TO REMAIN	Sign Type:	Sign Copy (Lettering):	Area (s.f.):	Permit No.:	
NEW SIGNAGE REQUESTED (Plans must show letter designation for each sign requested)					
Sign No.	Sign Type:	Project over R.O.W.? YES / NO			
Sign Area:	s.f. Freestanding Sign Hgt.:				
Sign Copy (Lettering):	FEE:				
Sign No.	Sign Type:	Project over R.O.W.? YES / NO			
Sign Area:	s.f. Freestanding Sign Hgt.:				
Sign Copy (Lettering):	FEE:				
Signature of Applicant:		Date: ____/____/____			
Total Area of Wall/Projecting Signage: _____ s.f. Total Area of Freestanding Signage: _____ s.f. Total Area of all permanent Signage: _____ s.f. (includes existing signage to remain)					
TOTAL FEE: \$ _____					
TYPE OF PERMIT(S) REQUIRED:					
Sign Permit <input type="checkbox"/>					
Special Clearance Permit <input type="checkbox"/>					
Building/Electrical Permit <input type="checkbox"/>					
Other <input type="checkbox"/>					
Zone	Scenic Overlay: YES / NO	Street Frontage: Linear Building Frontage:	L.F.		
3 Copies of each: Site Plans submitted <input type="checkbox"/> Color Photos submitted or Building Elevation submitted <input type="checkbox"/> Structural/Electrical Plan submitted: <input type="checkbox"/>					
Received by:		Date:			
Zoning Approval by: (858) 720-2440		<input type="checkbox"/>			
Code Approval by: (858) 720-2413		<input type="checkbox"/>			
Conditions/Corrections:					

TO CALCULATE LINEAR BUILDING FRONTAGE **SEE PAGE 3** FOR GUIDANCE.

Common Types of Signs

A complete list of all signs is contained in the Comprehensive Sign Ordinance.

“Advertising structure” means an on-site or off-site structure of any kind or character other than the main business identification sign, erected or maintained for outdoor advertising purposes, upon which any poster, bill, printing, painting, or other advertisement of any kind whatsoever is placed.

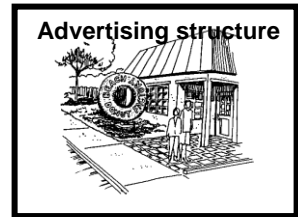

“Awning” means a roof-like protective cover constructed of metal, wood or other rigid material extending from all or a portion of a building such as a door, entrance, window or outdoor service area. For the purposes of this chapter a sign on an awning shall be considered to be a wall sign.

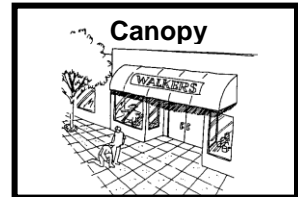

“Canopy” means a removable roof-like, protective cover constructed of a durable fabric or other flexible material extending from all or a portion of a building such as a door, entrance, window, or outdoor service area. For the purposes of this title, a sign located on a canopy shall be considered to be a wall sign.

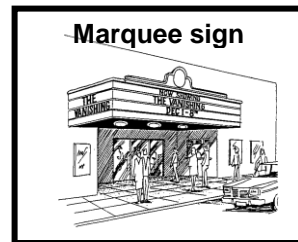

“Freestanding sign” means a sign which is supported by structures or supports that are placed on, or anchored in the ground and that are independent from any building or other structure. (See also “Monument sign”.)

“Banner, flag or pennant” means any cloth bunting, plastic, paper, fabric or similar material used for advertising purposes attached to or pinned on or from any structure, staff, pole, line, framing or vehicle, not including governmental flags.

“Marquee sign” means any sign attached to, or in any manner or made part of, a marquee.

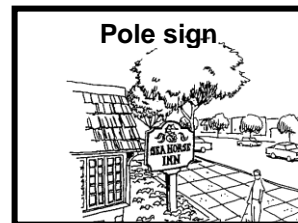

“Monument sign” means a low profile freestanding sign, with its base resting on the ground and typically incorporating the design and building materials complementary to the architectural theme of the buildings on the same property.

“Parapet” means that part of the wall which extends above the roof. For the purposes of this chapter the top of the parapet shall be considered to be the roofline. **ANY SIGN PROPOSED ABOVE THE PARAPET IS PROHIBITED**



“Pole sign” means a type of freestanding sign which is permanently supported by one or more poles or uprights.

“Portable sign” means any sign not permanently attached, or designed to be permanently attached to the ground or other permanent structure, or a sign designed to be transported by means of wheels; signs converted to A-frames or T-frames; and menu and sandwich board signs **PORTABLE SIGNS ARE PROHIBITED**



“Projecting sign” means any sign attached to and projecting from the wall of a building and not in the same plane as the wall.

“Wall sign” means a sign painted on, attached to, or erected against the wall of a building, structure, canopy or awning with the exposed face of the sign parallel to the plane of such wall or structure. For the purposes of this chapter, an architecturally integrated mansard sign shall be classified as a wall sign.

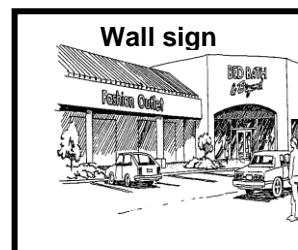

Calculating Linear Building Frontage

Please review the following illustrations and calculate the amount of sign you are allowed. To do this, measure the linear frontage of your building or business (it is "X" feet wide, and/or "X" feet long). If you are the sole business tenant in a building, use "Building Frontage" (Illustration 1, below). If you are one of several tenants, use "Business Frontage" (Illustration 2, below). REMINDER: You can only count frontages that contain an entrance open to the public during all business hours. The calculation is simple: you are allowed one SQUARE FOOT of sign for every LINEAR FOOT of frontage.

Illustration 1

Use if you are the sole business occupant of a building.

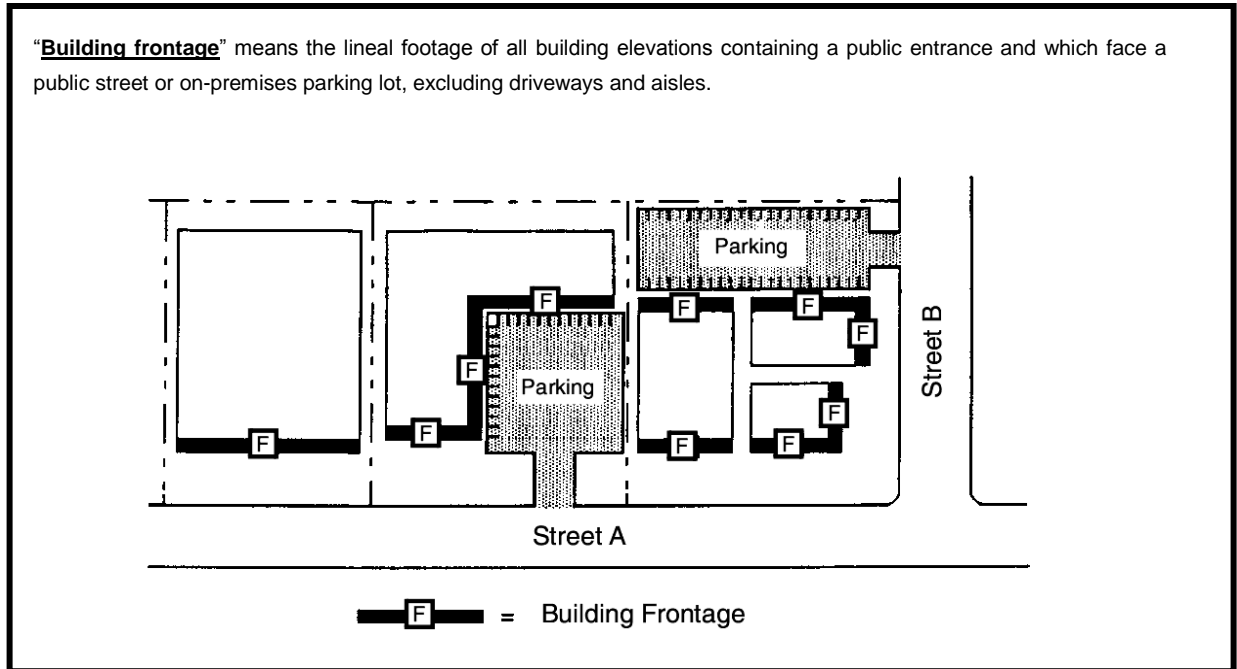
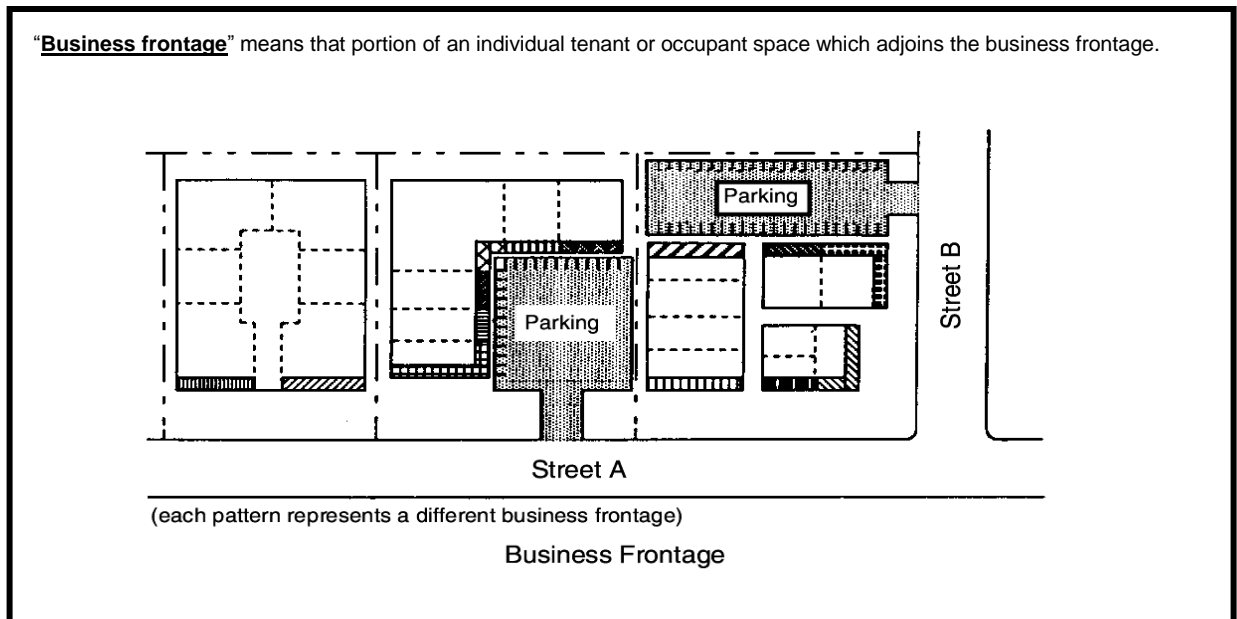

Illustration 2

Use if you are one of several tenants.



Items to Include With Your Application

Drawings

For public safety purposes, it is essential that we know how your sign is constructed and attached. Therefore each application must include a complete description of the material used in the construction of the sign and a clear description of how it is proposed to be attached to the building. In some instances a drawing should be attached to best illustrate these attributes (see Illustrations 3 and 4 below). Additionally, it is important that we know where you propose to erect the sign; therefore a site plan is necessary (see Illustration 5 on page 5). Finally, each sign should be drawn, and the drawing should include dimensions and the proposed size in square feet (see Illustration 6 on page 5).

Filing Fee

Please include one set of plans (11" x 17"), including site plan, sign illustration, and construction detail, with your application, and payment.

Are you considering a Grand Opening banner?

If you are a new business, you may want to include a "temporary grand opening banner" in your application which complies with the following requirements: 1) It may not exceed one square foot for each linear foot of building frontage, up to 32 square feet in area; 2) It may be displayed for a period not to exceed 60 days. (See 17.64.055 "Permitted temporary and special event banners" in the Comprehensive Sign Ordinance, for additional information.)

Illustration 3
Sample Attachment Detail Illustration

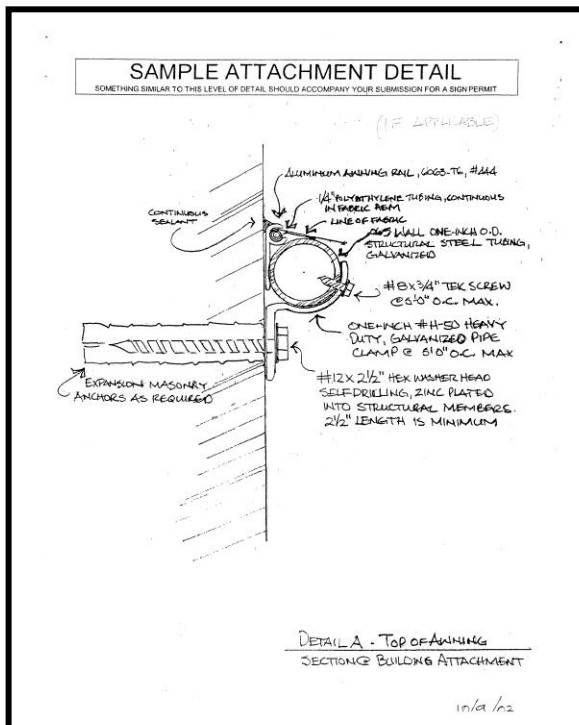

Illustration 4
Sample Construction Detail Illustration

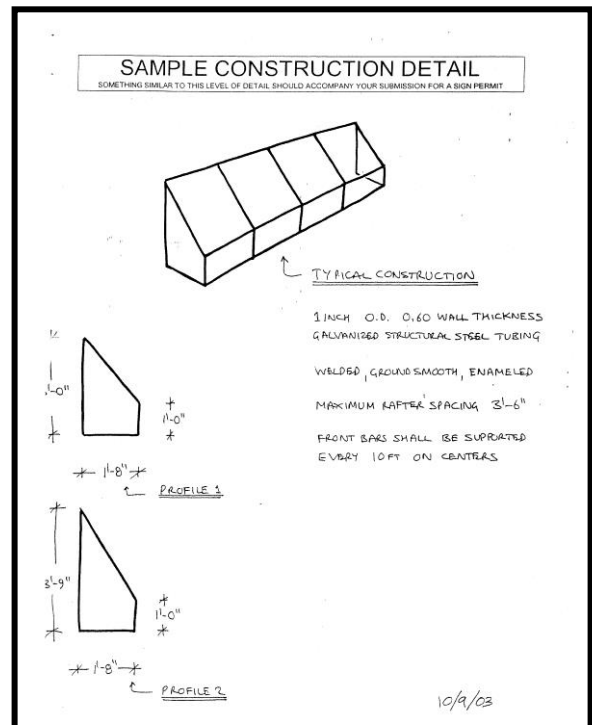

Illustration 5
Sample Sign Illustration

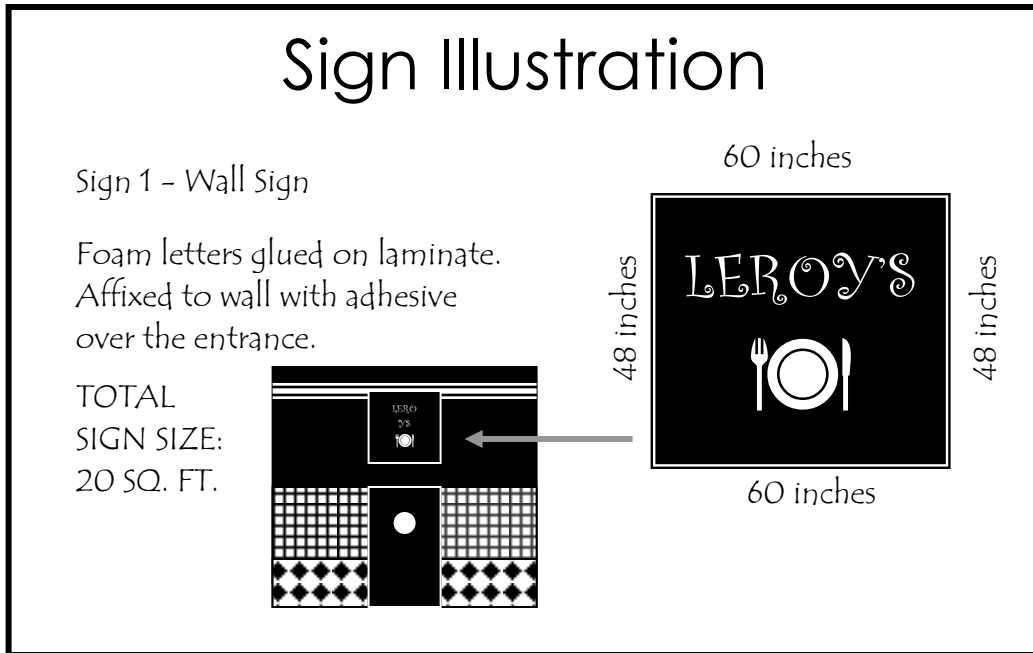
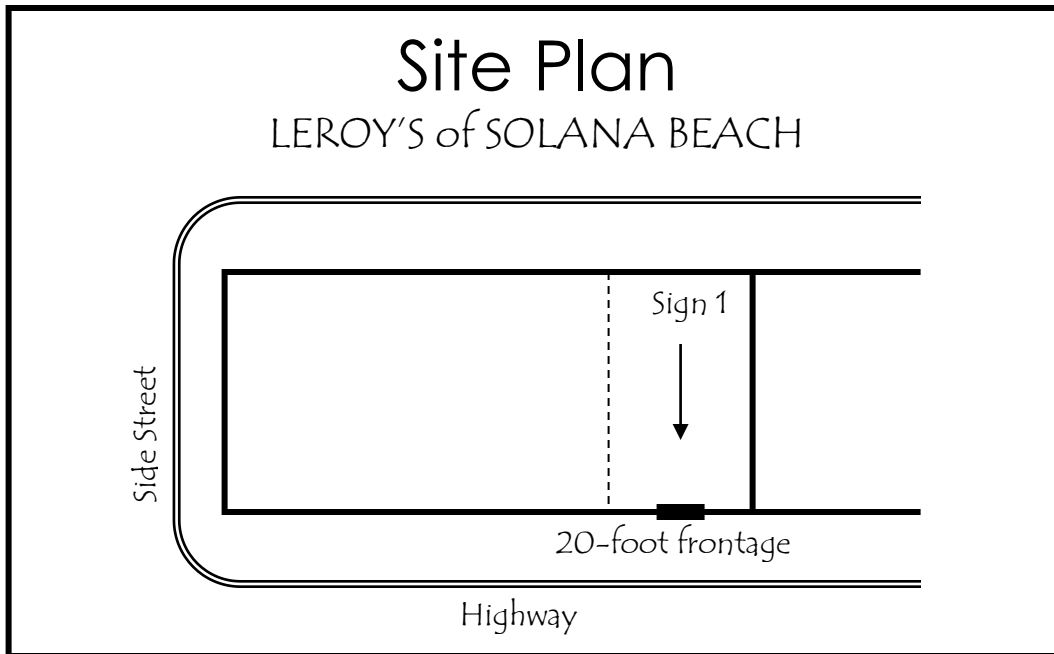

Illustration 6
Sample Site Plan



What Happens After You Submit an Application

The application is first reviewed by Planning, then routed to Engineering (only if it may have a potential sight-distance conflict) and Building. Due to the construction, placement and/or method of installation, the sign may also require a Building Permit. Please contact the Building Department at (858) 720-4450 for information on the permitting process and Building Permit fees.

SIGN PERMIT FINAL CHECKLIST

hat Your Sign Application Submission Should Include:

- One Application with shaded areas completed:
- One copy of the description (and/or illustrations) of the attachment methods:
- One copy of the description (and/or illustrations) of the construction:

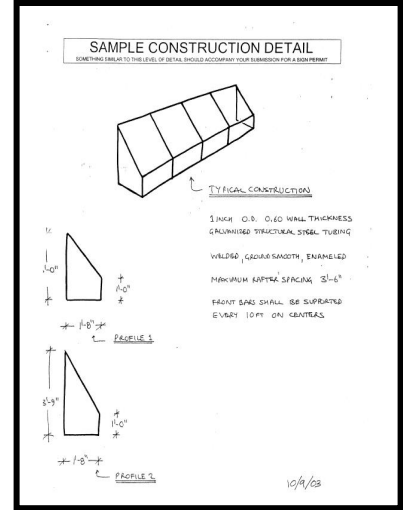
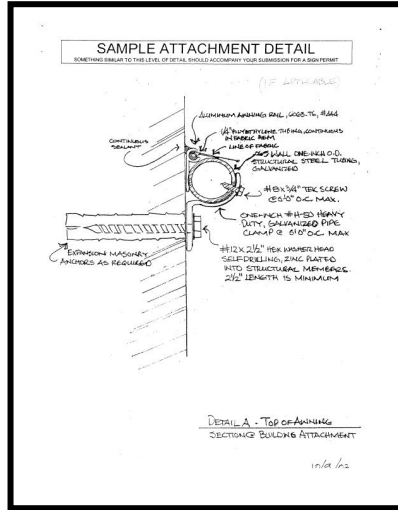

- One copy of an illustration of each sign, with measurements and size in square feet:
- One copy of a site plan depicting the location of all signs. The signs should be numbered and correspond to the numbers on the application.

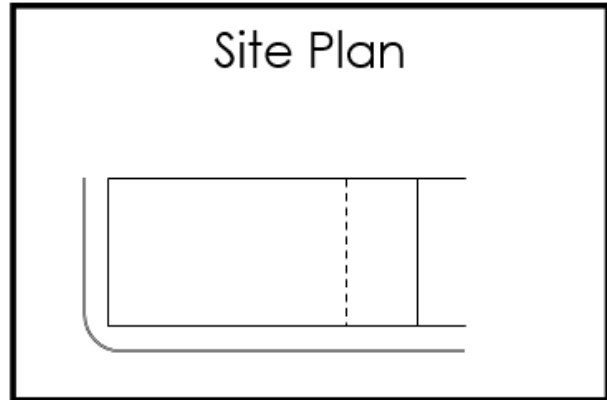

Cash OR Check
made payable to
"City of Solana Beach".

See current fee schedule for
permit fees.

