



CITY OF SOLANA BEACH
SOLANA BEACH CITY COUNCIL, SUCCESSOR AGENCY TO THE REDEVELOPMENT
AGENCY, PUBLIC FINANCING AUTHORITY, & HOUSING AUTHORITY

AGENDA

Joint REGULAR Meeting
Wednesday, May 22, 2024 * 6:00 p.m.

City Hall / Council Chambers, 635 S. Highway 101, Solana Beach, California

- City Council meetings are video recorded and archived as a permanent record. The [video](#) recording captures the complete proceedings of the meeting and is available for viewing on the City's website.
- Posted Reports & Supplemental Docs contain records up to the cut off time prior to meetings for processing new submittals. Complete records containing meeting handouts, PowerPoints, etc. can be obtained through a [Records Request](#).



PUBLIC MEETING ACCESS

The Regular Meetings of the City Council are scheduled for the 2nd and 4th Wednesdays and are broadcast live. The video taping of meetings are maintained as a permanent record and contain a detailed account of the proceedings. Council meeting tapings are archived and available for viewing on the City's [Public Meetings](#) webpage.

WATCH THE MEETING

- Live web-streaming: Meetings web-stream live on the City's website on the City's [Public Meetings](#) webpage. Find the large Live Meeting button.
- Live Broadcast on Local Govt. Channel: Meetings are broadcast live on Cox Communications - Channel 19 / Spectrum (Time Warner)-Channel 24 / AT&T U-verse Channel 99.
- Archived videos online: The video taping of meetings are maintained as a permanent record and contain a detailed account of the proceedings. Council meeting tapings are archived and available for viewing on the City's [Public Meetings](#) webpage.

AGENDA MATERIALS

A full City Council agenda packet including relative supporting documentation is available at City Hall, the Solana Beach Branch [Library](#) (157 Stevens Ave.), La Colonia Community Ctr., and online www.cityofsolanabeach.org. Agendas are posted at least 72 hours prior to regular meetings and at least 24 hours prior to special meetings. Writings and documents regarding an agenda of an open session meeting, [received](#) after the official posting, and distributed to the Council for consideration, will be made available for public viewing at the same time. In addition, items received at least 1 hour 30 minutes prior to the meeting time will be uploaded online with the agenda posting. Materials submitted for consideration should be forwarded to the [City Clerk's department](#) 858-720-2400. The designated location for viewing of hard copies is the City Clerk's office at City Hall during normal business hours.

PUBLIC COMMENTS

Written correspondence (supplemental items) regarding an agenda item at an open session meeting should be submitted to the City Clerk's Office at clerkoffice@cosb.org with a) Subject line to include the meeting date b) Include the Agenda Item # as listed on the Agenda.

- Correspondence received after the official posting of the agenda, but two hours prior to the meeting start time, on the meeting day, will be distributed to Council and made available online along with the agenda posting. All submittals received before the start of the meeting will be made part of the record.
- Written submittals will be added to the record and not read out loud.

And/Or

Verbal Comment Participation:

Please submit a speaker slip to the City Clerk prior to the meeting, or the announcement of the Section/Item, to provide public comment. Allotted times for speaking are outlined on the speaker's slip for each agenda section: Oral Communications, Consent, Public Hearings and Staff Reports. Public speakers have 3 minutes each to speak on each topic. Time may be donated by another

individual who is present at the meeting to allow an individual up to 6 minutes to speak. Group: Time may be donated by two individuals who are present at the meeting allowing an individual up to 10 minutes to speak. Group Hearings: For public hearings only, time may be donated by two individuals who are present at the meeting allowing an individual up to 15 minutes to speak.

COUNCIL DISCLOSURE

Pursuant to the Levine Act (Gov't Code Section 84308), any party to a permit, license, contract (other than competitively bid, labor or personal employment contracts) or other entitlement before the Council is required to disclose on the record any contribution, including aggregated contributions, of more than \$250 made by the party or the party's agents within the preceding 12 months to any Council Member. Participants and agents are requested to make this disclosure as well. The disclosure must include the name of the party or participant and any other person making the contribution, the name of the recipient, the amount of the contribution, and the date the contribution was made.

SPECIAL ASSISTANCE NEEDED

In compliance with the Americans with Disabilities Act of 1990, persons with a disability may request an agenda in appropriate alternative formats as required by Section 202. Any person with a disability who requires a modification or accommodation in order to participate in a meeting should direct such request to the [City Clerk's office](#) (858) 720-2400 at least 72 hours prior to the meeting.

As a courtesy to all meeting attendees, please set all electronic devices to silent mode and engage in conversations outside the Council Chambers.

<u>CITY COUNCILMEMBERS</u>		
Lesa Heebner Mayor		
Jewel Edson Deputy Mayor / Councilmember District 3		Kristi Becker Councilmember District 2
Jill MacDonald Councilmember District 4		David A. Zito Councilmember District 1

Alyssa Muto
City Manager

Johanna Canlas
City Attorney

Angela Ivey
City Clerk

SPEAKERS:

Please submit your speaker slip to the City Clerk prior to the meeting or the announcement of the Item. Allotted times for speaking are outlined on the speaker's slip for Oral Communications, Consent, Public Hearings and Staff Reports.

READING OF ORDINANCES AND RESOLUTIONS:

Pursuant to [Solana Beach Municipal Code](#) Section 2.04.460, at the time of introduction or adoption of an ordinance or adoption of a resolution, the same shall not be read in full unless after the reading of the title, further reading is requested by a member of the Council. If any Councilmember so requests, the ordinance or resolution shall be read in full. In the absence of such a request, this section shall constitute a waiver by the council of such reading.

CALL TO ORDER AND ROLL CALL:

CLOSED SESSION REPORT:

FLAG SALUTE:

APPROVAL OF AGENDA:

PROCLAMATIONS/CERTIFICATES: *Ceremonial*

None at the posting of this agenda

PRESENTATIONS: Ceremonial items that do not contain in-depth discussion and no action/direction.

None at the posting of this agenda

ORAL COMMUNICATIONS:

Comments relating to items on this evening's agenda are taken at the time the items are heard. This portion of the agenda provides an opportunity for members of the public to address the City Council on items relating to City business and not appearing on today's agenda by submitting a speaker slip (located on the back table) to the City Clerk. Pursuant to the Brown Act, no action shall be taken by the City Council on public comment items. Council may refer items to the City Manager for placement on a future agenda. The maximum time allotted for each presentation is THREE MINUTES. No donations of time are permitted (SBMC 2.04.190). Please be aware of the timer light on the Council Dais.

COUNCIL COMMUNITY ANNOUNCEMENTS / COMMENTARY:

An opportunity for City Council to make brief announcements or report on their activities. These items are not agendized for official City business with no action or substantive discussion.

A. CONSENT CALENDAR: (Action Items) (A.1. - A.6.)

Items listed on the Consent Calendar are to be acted in a single action of the City Council unless pulled for discussion. Any member of the public may address the City Council on an item of concern by submitting to the City Clerk a speaker slip (located on the back table) before the Consent Calendar is addressed. Those items removed from the Consent Calendar by a member of the Council will be trailed to the end of the agenda, while Consent Calendar items removed by the public will be heard immediately after approval of the Consent Calendar to hear the public speaker.

All speakers should refer to the public comment section at the beginning of the agenda for details. Please be aware of the timer light on the Council Dais.

A.1. Minutes of the City Council.

Recommendation: That the City Council

1. Approve the Minutes of the City Council meetings held on April 24, 2024.

[Item A.1. Report \(click here\)](#)

Posted Reports & Supplemental Docs contain records up to the cut off time, prior to the start of the meeting, for processing new submittals. The final official record containing handouts, PowerPoints, etc. can be obtained through a Records Request to the City Clerk's Office.

A.2. Register Of Demands. (File 0300-30)

Recommendation: That the City Council

1. Ratify the list of demands for April 20, 2024 – May 03, 2024.

[Item A.2. Report \(click here\)](#)

Posted Reports & Supplemental Docs contain records up to the cut off time, prior to the start of the meeting, for processing new submittals. The final official record containing handouts, PowerPoints, etc. can be obtained through a Records Request to the City Clerk's Office.

A.3. General Fund Adopted Budget for Fiscal Year 2023/2024 Changes. (File 0330-30)

Recommendation: That the City Council

1. Receive the report listing changes made to the Fiscal Year 2023-2024 General Fund Adopted Budget.

[Item A.3. Report \(click here\)](#)

Posted Reports & Supplemental Docs contain records up to the cut off time, prior to the start of the meeting, for processing new submittals. The final official record containing handouts, PowerPoints, etc. can be obtained through a Records Request to the City Clerk's Office.

A.4. Solana Beach Coastal Rail Trail Maintenance District Preliminary Engineer's Report, Annual Levy, and Collection of Assessments – Fiscal Year 2024/25.

(File 0495-20)

Recommendation: That the City Council

1. Adopt **Resolution 2024-046**, initiating the proceedings for the annual levy of assessments within the Coastal Rail Trail Maintenance District for Fiscal Year 2024/25.
2. Adopt **Resolution 2024-047**, approving the Preliminary Engineer's Report for proceedings of the annual levy of assessments within Coastal Rail Trail Maintenance District.
3. Adopt **Resolution 2024-048**, declaring intention to provide for the annual levy and collection of assessments in Coastal Rail Trail Maintenance District and setting a time and date for a public hearing for June 26, 2024.

[Item A.4. Report \(click here\)](#)

Posted Reports & Supplemental Docs contain records up to the cut off time, prior to the start of the meeting, for processing new submittals. The final official record containing handouts, PowerPoints, etc. can be obtained through a Records Request to the City Clerk's Office.

A.5. Solana Beach Lighting Maintenance District Engineer's Report, Annual Levy, and Collection of Assessments - Fiscal Year 2024/25. (File 0495-20)

Recommendation: That the City Council

1. Adopt **Resolution 2024-049** approving the Solana Beach Lighting Maintenance District Engineer's Report for Fiscal Year 2024/25 for proceedings of the annual levy of assessments within a special maintenance district.
2. Adopt **Resolution 2024-050** declaring intention to provide for an annual levy and collection of assessment in a special maintenance district and setting a time and date for a public hearing; and scheduling the public hearing for June 26, 2024.

[Item A.5. Report \(click here\)](#)

Posted Reports & Supplemental Docs contain records up to the cut off time, prior to the start of the meeting, for processing new submittals. The final official record containing handouts, PowerPoints, etc. can be obtained through a Records Request to the City Clerk's Office.

A.6. Exterior Painting and Stucco Repairs at City Hall - Notice of Completion.
(File 0710-20)

Recommendation: That the City Council

1. Adopt **Resolution 2024-060**:
 - a. Ratifying the City Manager's decision to execute Change Order No. 1 to the construction contract with Polychrome Construction, Inc., in an amount of \$39,085, for a total amount of \$86,830, for Fiscal Year 2023/24.
 - b. Authorizing the City Clerk to file a Notice of Completion.

[Item A.6. Report \(click here\)](#)

Posted Reports & Supplemental Docs contain records up to the cut off time, prior to the start of the meeting, for processing new submittals. The final official record containing handouts, PowerPoints, etc. can be obtained through a Records Request to the City Clerk's Office.

NOTE: The City Council shall not begin a new agenda item after 10:30 p.m. unless approved by a unanimous vote of all members present. (SBMC 2.04.070)

B. PUBLIC HEARINGS: (B.1. - B.3.)

This portion of the agenda provides citizens an opportunity to express their views on a specific issue as required by law after proper noticing by submitting a speaker slip (located on the back table) to the City Clerk. After considering all of the evidence, including written materials and oral testimony, the City Council must make a decision supported by findings and the findings must be supported by substantial evidence in the record. An applicant or designee(s) for a private development/business project, for which the public hearing is being held, is allotted a total of fifteen minutes to speak, as per SBMC 2.04.210. A portion of the fifteen minutes may be saved to respond to those who speak in opposition. *All other speakers should refer to the public comment section at the beginning of the agenda for time allotment.* Please be aware of the timer light on the Council Dais.

B.1. Public Hearing: 135 S. Sierra, Applicant: Las Brisas HOA, Case No: TE23-002, APN: 298-010-51-01 to 36. (File 0600-40)

Recommendation: That the City Council

1. Conduct the Public Hearing: Open the Public Hearing, Report Council Disclosures, Receive Public Testimony, and Close the Public Hearing.
2. If the City Council can make the required findings, adopt **Resolution 2024-029**, approving the request for a Time Extension for approvals and entitlements in Case No. CUP20-004 and setting the expiration date as February 9, 2025.

[Item B.1. Report \(click here\)](#)

Posted Reports & Supplemental Docs contain records up to the cut off time, prior to the start of the meeting, for processing new submittals. The final official record containing handouts, PowerPoints, etc. can be obtained through a Records Request to the City Clerk's Office.

B.2. Public Hearing: 255-265 Pacific Ave., Applicant: Alamo Family Trust, Sivage Family Revocable Trust, Bradley and Susan Stone, Case: MOD24-002.
(File 0600-40)

The proposed project meets the minimum zoning requirements under the SBMC, is consistent with the General Plan and may be found, as conditioned, to meet the discretionary findings to approve a modification to the approved CUP. Therefore, Staff recommends that the City Council:

1. Conduct the Public Hearing: Open the Public Hearing, Report Council Disclosures, Receive Public Testimony, and Close the Public Hearing.
2. Find the project exempt from the California Environmental Quality Act.
3. If the City Council makes the requisite findings and approves the project, adopt **Resolution 2024-061** conditionally approving a modification to the CUP for backfilling of existing eroded gullies within the existing geogrid reinforced slope, installation of secondary geogrid in the backfill of the gully repair, installation of temporary irrigation, and revegetation of the upper bluff with native container plants and hydroseeding on the coastal bluff below 255, 261, and 265 Pacific Avenue, Solana Beach.

[Item B.2. Report \(click here\)](#)

Posted Reports & Supplemental Docs contain records up to the cut off time, prior to the start of the meeting, for processing new submittals. The final official record containing handouts, PowerPoints, etc. can be obtained through a Records Request to the City Clerk's Office.

B.3. Public Hearing: Regional Transportation Improvement Program (RTIP) for Fiscal Years 2025-2029. (File 0840-30)

Recommendation: That the City Council

1. Conduct the Public Hearing: Open the Public Hearing, Report Council Disclosures, Receive Public Testimony, and Close the Public Hearing.
2. Consider Adoption of **Resolution 2024-042**, approving the 2025 Regional Transportation Improvement Program for Fiscal Years (FY) 2024/25 through FY 2028/29.

[Item B.3. Report \(click here\)](#)

Posted Reports & Supplemental Docs contain records up to the cut off time, prior to the start of the meeting, for processing new submittals. The final official record containing handouts, PowerPoints, etc. can be obtained through a Records Request to the City Clerk's Office.

C. STAFF REPORTS: (C.1.)

Submit speaker slips to the City Clerk.

All speakers should refer to the public comment section at the beginning of the agenda for time allotments. Please be aware of the timer light on the Council Dais.

C.1. Glencrest Sidewalk Project Update. (File 0820-45)

Recommendation: That the City Council

1. Receive report and provide direction to Staff.

[Item C.1. Report \(click here\)](#)

Posted Reports & Supplemental Docs contain records up to the cut off time, prior to the start of the meeting, for processing new submittals. The final official record containing handouts, PowerPoints, etc. can be obtained through a Records Request to the City Clerk's Office.

WORK PLAN COMMENTS:

Adopted June 28, 2023

COMPENSATION & REIMBURSEMENT DISCLOSURE:

GC: Article 2.3. Compensation: 53232.3. (a) Reimbursable expenses shall include, but not be limited to, meals, lodging, and travel. 53232.3 (d) Members of a legislative body shall provide brief reports on meetings attended at the expense of the local agency "City" at the next regular meeting of the legislative body.

COUNCIL COMMITTEE REPORTS: [Council Committees](#)

REGIONAL COMMITTEES: (outside agencies, appointed by this Council)

- a. City Selection Committee (meets twice a year) Primary-Heebner, Alternate-Edson
- b. Clean Energy Alliance (CEA) JPA: Primary-Becker, Alternate-Zito
- c. County Service Area 17: Primary-MacDonald, Alternate-Edson
- d. Escondido Creek Watershed Authority: Becker / Staff (no alternate).
- e. League of Ca. Cities' San Diego County Executive Committee: Primary-MacDonald, Alternate-Becker. Subcommittees determined by its members.
- f. League of Ca. Cities' Local Legislative Committee: Primary-MacDonald, Alternate-Becker
- g. League of Ca. Cities' Coastal Cities Issues Group (CCIG): Primary-MacDonald, Alternate-Becker
- h. North County Dispatch JPA: Primary-MacDonald, Alternate-Becker
- i. North County Transit District: Primary-Edson, Alternate-MacDonald
- j. Regional Solid Waste Association (RSWA): Primary-Zito, Alternate-MacDonald
- k. SANDAG: Primary-Heebner, 1st Alternate-Zito, 2nd Alternate-Edson. Subcommittees determined by its members.
- l. SANDAG Shoreline Preservation Committee: Primary-Becker, Alternate-Zito
- m. San Dieguito River Valley JPA: Primary-MacDonald, Alternate-Becker
- n. San Elijo JPA: Primary-Zito, Primary-Becker, Alternate-City Manager
- o. 22nd Agricultural District Association Community Relations Committee: Primary-Edson, Primary-Heebner

STANDING COMMITTEES: (All Primary Members) (Permanent Committees)

- a. Business Liaison Committee – Zito, Edson
- b. Fire Dept. Management Governance & Organizational Evaluation – Edson, MacDonald
- c. Highway 101 / Cedros Ave. Development Committee – Heebner, Edson
- d. Parks and Recreation Committee – Zito, Edson
- e. Public Arts Committee – Edson, Heebner
- f. School Relations Committee – Becker, MacDonald
- g. Solana Beach-Del Mar Relations Committee – Heebner, Edson

CITIZEN COMMISSION(S)

- a. Climate Action Commission – Zito, Becker

ADJOURN:

Next Regularly Scheduled Meeting is June 12, 2024

Always refer to the City's website Event Calendar for an updated schedule or contact City Hall. www.cityofsolanabeach.org 858-720-2400

AFFIDAVIT OF POSTING

STATE OF CALIFORNIA }
COUNTY OF SAN DIEGO } §
CITY OF SOLANA BEACH }

I, Angela Ivey, City Clerk of the City of Solana Beach, do hereby certify that this Agenda for the May 22, 2024 Council Meeting was called by City Council, Successor Agency to the Redevelopment Agency, Public Financing Authority, and the Housing Authority of the City of Solana Beach, California, was provided and posted on May 16, 2024 at 9:45 a.m. on the City Bulletin Board at the entrance to the City Council Chambers. Said meeting is held at 6:00 p.m., May 22, 2024, in the Council Chambers, at City Hall, 635 S. Highway 101, Solana Beach, California.

Angela Ivey, City Clerk
City of Solana Beach, CA

UPCOMING CITIZEN CITY COMMISSION AND COMMITTEE MEETINGS:

Regularly Scheduled, or Special Meetings that have been announced, are posted on each Citizen Commission's Agenda webpage. See the [Citizen Commission's Agenda webpages](#) or the City's Events [Calendar](#) for updates.

- **Budget & Finance Commission**
- **Climate Action Commission**
- **Parks & Recreation Commission**
- **Public Arts Commission**
- **View Assessment Commission**



CITY OF SOLANA BEACH
SOLANA BEACH CITY COUNCIL, SUCCESSOR AGENCY TO THE REDEVELOPMENT
AGENCY, PUBLIC FINANCING AUTHORITY, & HOUSING AUTHORITY

MINUTES

Joint Meeting - Closed Session

Wednesday, April 24, 2024 5:00 p.m.

City Hall / Council Chambers, 635 S. Highway 101, Solana Beach, California



CITY COUNCILMEMBERS

Lesa Heebner
Mayor

Jewel Edson
Deputy Mayor / Councilmember District 3

Kristi Becker
Councilmember District 2

Jill MacDonald
Councilmember District 4

David A. Zito
Councilmember District 1

Daniel King
Interim City Manager

Johanna Canlas
City Attorney

Angela Ivey
City Clerk

CALL TO ORDER AND ROLL CALL:

Mayor Heebner called the meeting to order at 5:55 p.m.

Present: Lesa Heebner, David A. Zito, Jewel Edson, Kristi Becker, Jill MacDonald
 Absent: None
 Also Present: Dan King, Interim City Manager
 Johanna Canlas, City Attorney

PUBLIC COMMENT ON CLOSED SESSION ITEMS (ONLY):

Report to Council Chambers and submit speaker slips to the City Clerk before the meeting recesses to closed session.

CLOSED SESSION:

1. CONFERENCE WITH LEGAL COUNSEL – EXISTING LITIGATION

Pursuant to Government Code Section 54956.9(d)(1)
 - MacDonald v. City of Solana Beach (37-2023-00038867-CU-PO-CTL)

2. CONFERENCE WITH LEGAL COUNSEL – ANTICIPATED LITIGATION

Pursuant to Government Code Section 54956.9(d)(2)
 One (1) Potential case(s).

No reportable action.

ADJOURN:

Mayor Heebner adjourned the meeting at 5:55 p.m.

Angela Ivey, City Clerk

Approved: _____



CITY OF SOLANA BEACH
SOLANA BEACH CITY COUNCIL, SUCCESSOR AGENCY TO THE REDEVELOPMENT
AGENCY, PUBLIC FINANCING AUTHORITY, & HOUSING AUTHORITY

MINUTES

Joint REGULAR Meeting
Wednesday, April 24, 2024 * 6:00 p.m.

City Hall / Council Chambers, 635 S. Highway 101, Solana Beach, California

- City Council meetings are video recorded and archived as a permanent record. The [video](#) recording captures the complete proceedings of the meeting and is available for viewing on the City's website.
- Posted Reports & Supplemental Docs contain records up to the cut off time prior to meetings for processing new submittals. Complete records containing meeting handouts, PowerPoints, etc. can be obtained through a [Records Request](#).



PUBLIC MEETING ACCESS

The Regular Meetings of the City Council are scheduled for the 2nd and 4th Wednesdays and are broadcast live. The video taping of meetings are maintained as a permanent record and contain a detailed account of the proceedings. Council meeting tapings are archived and available for viewing on the City's [Public Meetings](#) webpage.

WATCH THE MEETING

- Live web-streaming: Meetings web-stream live on the City's website on the City's [Public Meetings](#) webpage. Find the large Live Meeting button.
- Live Broadcast on Local Govt. Channel: Meetings are broadcast live on Cox Communications - Channel 19 / Spectrum (Time Warner)-Channel 24 / AT&T U-verse Channel 99.
- Archived videos online: The video taping of meetings are maintained as a permanent record and contain a detailed account of the proceedings. Council meeting tapings are archived and available for viewing on the City's [Public Meetings](#) webpage.

AGENDA MATERIALS

A full City Council agenda packet including relative supporting documentation is available at City Hall, the Solana Beach Branch [Library](#) (157 Stevens Ave.), La Colonia Community Ctr., and online www.cityofsolanabeach.org. Agendas are posted at least 72 hours prior to regular meetings and at least 24 hours prior to special meetings. Writings and documents regarding an agenda of an open session meeting, [received](#) after the official posting, and distributed to the Council for consideration, will be made available for public viewing at the same time. In addition, items received at least 1 hour 30 minutes prior to the meeting time will be uploaded online with the agenda posting. Materials submitted for consideration should be forwarded to the [City Clerk's department](#) 858-720-2400. The designated location for viewing of hard copies is the City Clerk's office at City Hall during normal business hours.

PUBLIC COMMENTS

Written correspondence (supplemental items) regarding an agenda item at an open session meeting should be submitted to the City Clerk's Office at clerkoffice@cosb.org with a) Subject line to include the meeting date b) Include the Agenda Item # as listed on the Agenda.

- Correspondence received after the official posting of the agenda, but two hours prior to the meeting start time, on the meeting day, will be distributed to Council and made available online along with the agenda posting. All submittals received before the start of the meeting will be made part of the record.
- Written submittals will be added to the record and not read out loud.

And/Or

Verbal Comment Participation:

Please submit a speaker slip to the City Clerk prior to the meeting, or the announcement of the Section/Item, to provide public comment. Allotted times for speaking are outlined on the speaker's slip for each agenda section: Oral Communications, Consent, Public Hearings and Staff Reports. Public speakers have 3 minutes each to speak on each topic. Time may be donated by another

individual who is present at the meeting to allow an individual up to 6 minutes to speak. Group: Time may be donated by two individuals who are present at the meeting allowing an individual up to 10 minutes to speak. Group Hearings: For public hearings only, time may be donated by two individuals who are present at the meeting allowing an individual up to 15 minutes to speak.

SPECIAL ASSISTANCE NEEDED

In compliance with the Americans with Disabilities Act of 1990, persons with a disability may request an agenda in appropriate alternative formats as required by Section 202. Any person with a disability who requires a modification or accommodation in order to participate in a meeting should direct such request to the [City Clerk's office](#) (858) 720-2400 at least 72 hours prior to the meeting.

As a courtesy to all meeting attendees, please set all electronic devices to silent mode and engage in conversations outside the Council Chambers.

<u>CITY COUNCILMEMBERS</u>		
Lesa Heebner Mayor		
Jewel Edson Deputy Mayor / Councilmember District 3		Kristi Becker Councilmember District 2
Jill MacDonald Councilmember District 4		David A. Zito Councilmember District 1

Dan King
Interim City Manager

Johanna Canlas
City Attorney

Angela Ivey
City Clerk

SPEAKERS:

Please submit your speaker slip to the City Clerk prior to the meeting or the announcement of the Item. Allotted times for speaking are outlined on the speaker's slip for Oral Communications, Consent, Public Hearings and Staff Reports.

READING OF ORDINANCES AND RESOLUTIONS:

Pursuant to [Solana Beach Municipal Code](#) Section 2.04.460, at the time of introduction or adoption of an ordinance or adoption of a resolution, the same shall not be read in full unless after the reading of the title, further reading is requested by a member of the Council. If any Councilmember so requests, the ordinance or resolution shall be read in full. In the absence of such a request, this section shall constitute a waiver by the council of such reading.

CALL TO ORDER AND ROLL CALL:

Mayor Heebner called the meeting to order at 6:03 p.m.

Present: Lesa Heebner, Jewel Edson, Kristi Becker, Jill MacDonald, David A. Zito

Absent: None

Also Dan King, Interim City Manager

Present: Johanna Canlas, City Attorney
Angela Ivey, City Clerk
Mo Sammak, City Engineer/Public Works Dir.
Rachel Jacobs, Finance Dir.
Joseph Lim, Community Development Dir.

CLOSED SESSION REPORT: None

FLAG SALUTE:

APPROVAL OF AGENDA:

Motion: Moved by Councilmember Becker and second by Councilmember Zito to approve. **Approved 5/0.** Ayes: Heebner, Edson, Becker, MacDonald, Zito. Noes: None. Motion carried unanimously.

PROCLAMATIONS/CERTIFICATES: *Ceremonial*

- Earth Day/Month

Mayor Heebner read a proclamation in honor of Earth Day on April 22nd focusing on environmental awareness and Solana Beach's efforts to combat climate change.

- San Diego County Fair

Mayor Heebner presented a proclamation to Carlene Moore, Del Mar Fairgrounds 22nd District Agricultural Association, recognizing the significance of the annual San Diego County Fair, its history, and partnership with the City, and declaring June 12th San Diego County Fair Day in Solana Beach.

Carlene Moore, CEO Del Mar Fairgrounds 22nd District Agricultural Association, acknowledged the City's partnership with the Fair and reviewed the upcoming events at the Fair beginning on June 12th.

ORAL COMMUNICATIONS:

Comments relating to items on this evening's agenda are taken at the time the items are heard. This portion of the agenda provides an opportunity for members of the public to address the City Council on items relating to City business and not appearing on today's agenda by submitting a speaker slip (located on the back table) to the City Clerk. Pursuant to the Brown Act, no action shall be taken by the City Council on public comment items. Council may refer items to the City Manager for placement on a future agenda. The maximum time allotted for each presentation is THREE MINUTES. No donations of time are permitted (SBMC 2.04.190). Please be aware of the timer light on the Council Dais.

Terri-Ann Skelly, San Dieguito Alliance for Drug-Free Youth, submitted a handout (on file) and spoke of concerns regarding the sale of kratom, an unregulated psychoactive substance, and highlighted the dangers associated with its use. She asked Council to implement an ordinance like one adopted by the City of Oceanside which bans the sale of kratom and other synthetic drugs.

Peggy Walker, San Dieguito Alliance for Drug-Free Youth, expressed concerns about the sale of kratom in the City and referenced warnings from the FDA and the Mayo Clinic regarding its psychoactive and addictive properties as well as the lack of oversight and age restrictions. She said that the sale of kratom is prevalent in gas stations and café bars and that the long-term effects of these drugs liken its effects to opioids. She urged Council to adopt an ordinance like the one adopted in the City of Oceanside and provide information on the FDA's stance on kratom.

Kelly McCormick, Public Health Educator, asked the Council to ban the sale of kratom products in Solana Beach and referenced an investigative report which highlighted hundreds of overdoses and deaths related to kratom. She said the concerns for the lack of regulation and warning labels, the variability of active ingredients, harmful interactions with other substances, and its addictive nature should be considered for a ban on sales in Solana Beach and asked Council to protect the community.

COUNCIL COMMUNITY ANNOUNCEMENTS / COMMENTARY:

An opportunity for City Council to make brief announcements or report on their activities. These items are not agendized for official City business with no action or substantive discussion.

A. CONSENT CALENDAR: (Action Items) (A.1. - A.9.)

Items listed on the Consent Calendar are to be acted in a single action of the City Council unless pulled for discussion. Any member of the public may address the City Council on an item of concern by submitting to the City Clerk a speaker slip (located on the back table) before the Consent Calendar is addressed. Those items removed from the Consent Calendar by a member of the Council will be trailed to the end of the agenda, while Consent Calendar items removed by the public will be heard immediately after approval of the Consent Calendar to hear the public speaker.

All speakers should refer to the public comment section at the beginning of the agenda for details. Please be aware of the timer light on the Council Dais.

A.1. Minutes of the City Council.

Recommendation: That the City Council

1. Approve the Minutes of the City Council meetings held on March 13, 2024 and March 27, 2024.

Approved Minutes <https://www.cityofsolanabeach.org/en/government/public-meetings/agendas-minutes-videos>

Motion: Moved by Deputy Mayor Edson and second by Councilmember MacDonald to approve. **Approved 5/0.** Ayes: Heebner, Edson, Becker, MacDonald, Zito. Noes: None. Motion carried unanimously.

A.2. Register Of Demands. (File 0300-30)

Recommendation: That the City Council

1. Ratify the list of demands for March 23, 2024 – April 5, 2024.

[Item A.2. Report \(click here\)](#)

Motion: Moved by Deputy Mayor Edson and second by Councilmember MacDonald to approve. **Approved 5/0.** Ayes: Heebner, Edson, Becker, MacDonald, Zito. Noes: None. Motion carried unanimously.

A.3. General Fund Adopted Budget for Fiscal Year 2023/2024 Changes. (File 0330-30)

Recommendation: That the City Council

1. Receive the report listing changes made to the Fiscal Year 2023-2024 General Fund Adopted Budget.

[Item A.3. Report \(click here\)](#)

Motion: Moved by Deputy Mayor Edson and second by Councilmember MacDonald to approve. **Approved 5/0.** Ayes: Heebner, Edson, Becker, MacDonald, Zito. Noes: None. Motion carried unanimously.

A.4. Street Maintenance & Repair Project Fiscal Year 2022-23 Notice of Completion. (File 0820-35)

Recommendation: That the City Council

1. Adopt **Resolution 2024-004:**
 - a. Authorizing the City Council to accept, as complete, the FY 2022-23 Street Maintenance & Repair Project, Bid No. 2023-07, performed by Quality Construction & Engineering.
 - b. Authorizing the City Clerk to file a Notice of Completion.

[Item A.4. Report \(click here\)](#)

Motion: Moved by Deputy Mayor Edson and second by Councilmember MacDonald to approve. **Approved 5/0.** Ayes: Heebner, Edson, Becker, MacDonald, Zito. Noes: None. Motion carried unanimously.

A.5. Security and Alarm Monitoring Services. (File 0700-40)

Recommendation: That the City Council

1. Adopt **Resolution 2024-026:**
 - a. Authorizing the City Manager to execute a Professional Services Agreement, on behalf of the City, with Rancho Santa Fe Security for security and alarm monitoring services in Fiscal Year 2024/25 in an amount not to exceed \$17,000 for Fiscal year 2024/25 from account 1006560-65300.
 - b. Authorizing the City Manager to extend the agreement up to four additional one-year terms, at the City's option, at an amount not to exceed the amount budgeted in each subsequent year.
 - c. Authorizing the City Manager to increase the annual not to exceed amount by 5% for FY 2025/26, 4.8% for FY 2026/27, 4.5% for FY 2027/28, 4.3% for FY 2028/29.
 - d. Authorizing the City Treasurer to amend the Fiscal Year 2024/25 Budget accordingly.

[Item A.5. Report \(click here\)](#)

Motion: Moved by Deputy Mayor Edson and second by Councilmember MacDonald to approve. **Approved 5/0.** Ayes: Heebner, Edson, Becker, MacDonald, Zito. Noes: None. Motion carried unanimously.

A.6. Trash Abatement Services. (File 0700-25)

Recommendation: That the City Council

1. Adopt **Resolution 2024-037:**
 - a. Authorizing the City Manager to execute a Professional Services Agreement with PRIDE Industries, in an amount not to exceed \$51,599.69 for FY 2024/25, for trash abatement, minor landscaping and other duties as assigned in public areas to be split between Street Sweeping account 1006550-65300 and Public Facilities account 1006570-65300.
 - b. Authorizing the City Manager to extend the agreement for up to four additional one-year terms at the City's option in an amount not to exceed \$51,599.69 per year.
 - c. Authorizing the City Treasurer to amend the FY 2024/25 Adopted Budget accordingly.

[Item A.6. Report \(click here\)](#)

Motion: Moved by Deputy Mayor Edson and second by Councilmember MacDonald to approve. **Approved 5/0.** Ayes: Heebner, Edson, Becker, MacDonald, Zito. Noes: None. Motion carried unanimously.

A.7. Street Maintenance and Repairs Project Fiscal Year 2023-24. (File 0820-35)

Recommendation: That the City Council

1. Adopt **Resolution 2024-043:**
 - a. Approving the list of streets scheduled for maintenance and repairs as part of the 2023/24 Street Maintenance and Repairs Project.
 - b. Authorizing the City Engineer to advertise for construction bids for the 2023/24 Street Maintenance and Repairs Project.

[Item A.7. Report \(click here\)](#)

Motion: Moved by Deputy Mayor Edson and second by Councilmember MacDonald to approve. **Approved 5/0.** Ayes: Heebner, Edson, Becker, MacDonald, Zito. Noes: None. Motion carried unanimously.

A.8. Americans with Disability Act (ADA) Pedestrian Ramps. (File 0820-20)

Recommendation: That the City Council

1. Adopt **Resolution 2024-041:**
 - a. Awarding a construction contract to LC Paving & Sealing in the amount of \$54,300 for the ADA Pedestrian Ramps, Bid No. 2024-05.
 - b. Approving an amount of \$5,430 for construction contingency.
 - c. Authorizing the City Manager to execute the construction contract on behalf of the City.
 - d. Appropriating \$6,921 to the Federal Grants revenue account and to the ADA Pedestrian Ramps CIP project, both in the CDBG fund.

- e. Appropriating \$7,809 to the ADA Pedestrian Ramps CIP project from Gas Tax.
- f. Authorizing the City Treasurer to amend the FY 2023/24 Adopted Budget accordingly.

[Item A.8. Report \(click here\)](#)

Motion: Moved by Deputy Mayor Edson and second by Councilmember MacDonald to approve. **Approved 5/0.** Ayes: Heebner, Edson, Becker, MacDonald, Zito. Noes: None. Motion carried unanimously.

A.9. Temporary Lifeguard Supervisor Position Addition. (File 0510-00)

Recommendation: That the City Council

1. Approve **Resolution 2024-044** approving the Temporary/Seasonal Lifeguard Supervisor classification and updating the FY 2023/2024 Temporary/Part-Time/Seasonal Salary Schedule 6 accordingly.

[Item A.9. Report \(click here\)](#)

Motion: Moved by Deputy Mayor Edson and second by Councilmember MacDonald to approve. **Approved 5/0.** Ayes: Heebner, Edson, Becker, MacDonald, Zito. Noes: None. Motion carried unanimously.

B. PUBLIC HEARINGS: (B.1.)

This portion of the agenda provides citizens an opportunity to express their views on a specific issue as required by law after proper noticing by submitting a speaker slip (located on the back table) to the City Clerk. After considering all of the evidence, including written materials and oral testimony, the City Council must make a decision supported by findings and the findings must be supported by substantial evidence in the record. An applicant or designee(s) for a private development/business project, for which the public hearing is being held, is allotted a total of fifteen minutes to speak, as per SBMC 2.04.210. A portion of the fifteen minutes may be saved to respond to those who speak in opposition. *All other speakers should refer to the public comment section at the beginning of the agenda for time allotment.* Please be aware of the timer light on the Council Dais.

B.1. Public Hearing: 718-732 Stevens Avenue, Applicant: 3981 Garfield St. LLC, Case No: DRP22-003/SMP22-001/SDP22-001, APN: 298-164-10 & 13. (File 0600-40)

The proposed project meets the minimum zoning requirements under the SBMC, may be found to be consistent with the General Plan and may be found, as conditioned, to meet the discretionary findings required as discussed in this report to approve a DRP and Major Subdivision. Therefore, should the City Council be able to make the findings to approve the DRP and SMAP, Staff recommends that the City Council:

1. Conduct the Public Hearing: Open the Public Hearing, Report Council Disclosures, Receive Public Testimony, and Close the Public Hearing.
2. Find the project exempt from the California Environmental Quality Act pursuant to Section 15332 of the State CEQA Guidelines; and

3. If the City Council can make the requisite findings and approve the Project, adopt **Resolution 2024-045** conditionally approving a DRP, SMAP, and SDP for the Stevens 13 Avenue Project at 718-732 Stevens Avenue, Solana Beach.

[Item B.1. Report \(click here\)](#)

[Item B.1. Updated Report #1 \(added 4-24-24 at 12:15pm\)](#)

Posted Reports & Supplemental Docs contain records up to the cut off time, prior to the start of the meeting, for processing new submittals. The final official record containing handouts, PowerPoints, etc. can be obtained through a Records Request to the City Clerk's Office.

Dan King, Interim City Manager, introduced the item.

Corey Andrews, Principal Planner, presented a PowerPoint (on file).

Mayor Heebner opened the public hearing.

Council disclosures.

Council and Staff discussed height of the buildings, parking layout, trash enclosure size, solar panel installation, fire access, the potential impact on stormwater runoff into nearby Stevens Creek, assurances regarding compliance with building codes, fire safety standards, and stormwater management requirements, the feasibility of certain design elements, such as the turning radius for parking and the adequacy of the trash enclosure size, and the possibility of incorporating permeable surfaces for parking areas to mitigate runoff impacts.

Tim Golba, Golba Architecture, presented a PowerPoint (on file) of the design concepts for the proposed development project, highlighting key aspects such as site layout, building placement, parking arrangements, and landscaping. He reviewed the efforts to integrate the project with the existing neighborhood while utilizing the site's topography to create a balanced and visually appealing design, and the engagement with neighbors through the sharing of renderings to provide a realistic visualization of the project's impact.

Council and Applicant discussed the garage parking and the allowance for additional parking outside of the garages as surplus guest parking, the design feature to prevent easy access between units for the safety and accessibility of roof decks between buildings, the choice of materials for railings and openness to using glass railings for visibility, considering native and drought-tolerant plant materials for landscaping, and utilizing garage spaces for parking rather than storage.

Lawrence and Melissa Gallego presented posters and said that the project was a three-story building towering over their backyard and disrupting their view and privacy, that there were issues regarding parking, sunlight, and the invasion of privacy due to the height of the building and the positioning of decks, and asked Council to mitigate these concerns by reducing the height of the building and the number of units.

Danny Hernandez said that he had concerns about the proposed three-story buildings, worries about parking and traffic congestion, particularly regarding the tightness of the driveways in the proposed development, that the neighborhood was predominantly zoned for two-story buildings and suggested that reducing the height of the new development would better align with the character of the area.

Tara Hernandez said she was speaking in support of neighbors Melissa and Larry Gallegos and that she empathized with her neighbors' situation, as a similar issue had occurred with her own property, that the project's size had an impact on shadows cast on neighboring houses, that she advocated for reducing the project to two stories to preserve the character of the neighborhood and prevent future developments from overshadowing the area.

Maura Griffin said that the building heights in the area should remain unchanged, the need for the building to be lowered, that more green space be included, and concerns about the number of units proposed for the development.

Richard Cordes said that he opposed the proposed development, citing concerns about the impact on the scenic view of Stevens Creek Valley from Hernandez Street that the proposed building was a giant that they do not want in the area, and that it should be reduced in size.

Chad Arendsen stated concerns about the proposed development's impact on the neighborhood's character and affordability, the importance of balancing return on investment (ROI) with community needs, that the proposed density increase does not adequately benefit the community, particularly in terms of affordable housing, and urged Council to consider making the project conform to existing regulations by limiting height and maintaining a lower unit count to better align with community interests.

PJ Chrysostomides, Applicant, said that they originally planned to build 11 units instead of nine, that this layout was a result of working with the City to meet all requirements, that the height of the existing buildings are 30 ft., that the density bonus was warranted given the affordable housing component, that the project was carefully planned to mitigate issues with parking and height, that the project would enhance the community preserving the neighborhood's character while providing much-needed housing, and that landscape plans would minimize visual impact on neighboring properties.

Council and Applicant discussed that the reduction of the height of the back buildings was not economically feasible, that they would be willing to remove rooftop decks if the community felt they were not historically appropriate, that the developer agreed to consider using solid railings instead of glass at the back to provide more privacy to neighboring properties, and that landscaping options should be chosen to soften the visual impact of the development.

Johanna Canlas, City Attorney, explained the limitations imposed by state law on the Council's discretion regarding land use decisions and were required to adhere to objective standards and could not change them to reduce density.

Council discussed their limitations and frustration with the process and encouraged the community to advocate for restoring local land use authority to cities.

Motion: Moved by Councilmember Zito and second by Deputy Mayor Edson to close the public hearing. **Approved 5/0.** Ayes: Heebner, Edson, Becker, MacDonald, Zito. Noes: None. Motion carried unanimously.

Council discussed modifications and requested that the Applicant work with the neighbors in choosing appropriate vegetation for the east end of the project to shield the project's view.

Motion: Moved by Deputy Mayor Edson and second by Councilmember MacDonald to approve. **Approved 5/0** with modifications to 1) remove roof decks 2) garages be used for parking 3) that rear balcony rails be opaque and not see through 4) increase vegetation on east end of project 5) native and drought tolerant plantings where feasibility. Ayes: Heebner, Edson, Becker, MacDonald, Zito. Noes: None. Motion carried unanimously.

Mayor Heebner recessed the meeting at 7:55 p.m. for a break and reconvened at 8:02 p.m.

C. STAFF REPORTS: (C.1.)

Submit speaker slips to the City Clerk.

All speakers should refer to the public comment section at the beginning of the agenda for time allotments. Please be aware of the timer light on the Council Dais.

C.1. Public Right-of-Way Parkway Surface Alternatives. (File 0820-18)

Recommendation: That the City Council

1. Receive report, discuss and provide direction, as necessary.

[Item C.1. Report \(click here\)](#)

[Item C.1. Supplemental Docs \(updated 4-24-24 at 5:25pm\)](#)

Posted Reports & Supplemental Docs contain records up to the cut off time, prior to the start of the meeting, for processing new submittals. The final official record containing handouts, PowerPoints, etc. can be obtained through a Records Request to the City Clerk's Office.

Dan King, Interim City Manager, introduced the item.

Mo Sammak, Engineering/Public Works Dir., presented a PowerPoint (on file) giving an overview of the current state of right-of-way improvements and seeking direction from the Council on potential alternative options.

Catherine Barnes expressed support for expanding options for approved ground coverings in the right-of-way areas in front of houses and said that there were benefits of decomposed granite (DG) in certain circumstances but highlighted its limitations, particularly on sloped properties where it can cause runoff issues and create hazards for pedestrians, especially those with disabilities. She suggested alternative options such as pavers to achieve a balance of safety, aesthetics, and environmental responsibility.

Council discussion centered on finding suitable surface options for city rights-of-way, particularly driveways and parking areas, the use of Decomposed Granite (DG) and alternative options for surfacing public areas and walkways, that DG is favored for its rural

and informal look, but it may not be suitable for all locations, such as steep slopes and areas prone to water runoff, the issues with DG maintenance including the breakdown of bonding agents and the need for frequent restoration, the need for surfaces to be walkable and compatible with mobility aids like walkers and wheelchairs for safety and accessibility, alternative materials like pavers, stamped concrete, and crushed rock, developing guidelines and policies for right-of-way improvements, questions about permit fees for maintenance projects in the right-of-way and possible reduced fees for such projects, and the need for a balance between aesthetics, environmental impact, safety, and maintenance when selecting surfacing materials for public areas.

WORK PLAN COMMENTS:

Adopted June 28, 2023

Mayor Heebner said that she expected a public speaker requesting that Cipriana Gonzales be considered for a La Colonia commemorative plaque on the tot lot.

COMPENSATION & REIMBURSEMENT DISCLOSURE: None

GC: Article 2.3. Compensation: 53232.3. (a) Reimbursable expenses shall include, but not be limited to, meals, lodging, and travel. 53232.3 (d) Members of a legislative body shall provide brief reports on meetings attended at the expense of the local agency “City” at the next regular meeting of the legislative body.

COUNCIL COMMITTEE REPORTS: [Council Committees](#)

REGIONAL COMMITTEES: (outside agencies, appointed by this Council)

ADJOURN:

Mayor Heebner adjourned the meeting at 9:04 p.m.

Angela Ivey, City Clerk

Approved: _____



STAFF REPORT CITY OF SOLANA BEACH

TO: Honorable Mayor and City Councilmembers
FROM: Alyssa Muto, City Manager
MEETING DATE: May 22, 2024
ORIGINATING DEPT: Finance
SUBJECT: Register of Demands

BACKGROUND:

Section 3.04.020 of the Solana Beach Municipal Code requires that the City Council ratify a register of demands which represents all financial demands made upon the City for the applicable period.

Register of Demands: 04/20/2024 through 05/03/2024

Check Register - Disbursement Fund (Attachment 1)		\$	933,661.19
Net Payroll Retiree Health	May 3, 2024		2,975.00
Net Payroll Staff O22	April 26, 2024		<u>300,317.54</u>
TOTAL		\$	<u>1,236,953.73</u>

DISCUSSION:

Staff certifies that the register of demands has been reviewed for accuracy, that funds are available to pay the above demands, and that the demands comply with the adopted budget.

CEQA COMPLIANCE STATEMENT:

Not a project as defined by CEQA.

FISCAL IMPACT:

The register of demands for April 20, 2024 through May 3, 2024 reflects total expenditures of \$1,236,953.73 from various City sources.

WORK PLAN:

N/A

CITY COUNCIL ACTION: _____

OPTIONS:

- Ratify the register of demands.
- Do not ratify and provide direction.

DEPARTMENT RECOMMENDATION:

Staff recommends that the City Council ratify the above register of demands.

CITY MANAGER'S RECOMMENDATION:

Approve Department Recommendation.

A handwritten signature in blue ink, appearing to read 'Alyssa Muto', written over a horizontal line.

Alyssa Muto, City Manager

Attachments:

1. Check Register – Disbursement Fund



City of Solana Beach

Register of Demands

4/20/2024 - 5/3/2024

Department Vendor	Description	Date	Check/EFT Number	Amount
100 - GENERAL FUND				
MISSION SQUARE PLAN 302817	Payroll Run 1 - Warrant O22	04/25/2024	9001418	\$17,230.09
SOLANA BEACH FIREFIGHTERS ASSOC	Payroll Run 1 - Warrant O22	04/25/2024	9001423	\$900.00
DEPARTMENT OF CONSERVATION	OCT-DEC 23-SMIP FEES	04/25/2024	106576	\$1,358.32
DEPARTMENT OF CONSERVATION	JAN-MAR 24-SMIP FEE	04/25/2024	106576	\$1,931.42
CALPERS	O21 PERS 04/12/24 PD (04/22/24 PERS)	04/22/2024	9042224	\$65,266.57
CALPERS	O22 457 CONTRIBUTION	04/25/2024	911032294	\$2,350.40
CALPERS	O22 PERS 04/26/24 PD (05/02/24 PERS)	05/02/2024	9050224	\$65,846.29
PRE-PAID LEGAL SERVICES, INC	APR 24 - PPD LEGAL	05/03/2024	106619	\$25.90
AFLAC	APRIL 24	05/03/2024	106595	\$1,005.18
DIVISION OF THE STATE ARCHITECT	SB1186 FEES: 2023 QTR 4/2024 QTR1	05/03/2024	106609	\$357.20
DIVISION OF THE STATE ARCHITECT	SB1186 FEES: 2023 QTR 4/2024 QTR1	05/03/2024	106609	\$323.60
SELF INSURED SERVICES COMPANY	MAY 24- LIFE&ADD INS/SUPP LIFE INS/LTD	05/03/2024	9001430	\$1,218.35
SELF INSURED SERVICES COMPANY	MAY 24- LIFE&ADD INS/SUPP LIFE INS/LTD	05/03/2024	9001430	\$350.75
SELF INSURED SERVICES COMPANY	MAY 24- LIFE&ADD INS/SUPP LIFE INS/LTD	05/03/2024	9001430	\$1,122.10
SELF INSURED SERVICES COMPANY	MAY 24	05/03/2024	9001431	\$2,837.80
INSTATAX	O22 TAX PAYMENT	04/24/2024	990120305	\$38,064.48
INSTATAX	O22 TAX PAYMENT	04/24/2024	990120305	\$1,252.10
INSTATAX	O22 TAX PAYMENT	04/24/2024	990120305	\$9,195.06
INSTATAX	O22 TAX PAYMENT	04/24/2024	990120305	\$15,094.97
INSTATAX	O22 TAX PAYMENT	04/24/2024	990120305	\$2,593.57
PAYMENTUS CORPORATION	MARCH 24	04/25/2024	106586	\$655.46
FIDELITY SECURITY LIFE INSURANCE COMPANY	MAY 24-VISION	05/03/2024	106611	\$497.12
IAFF-MERP	APR 24 FF TRUST PAYMENT	05/03/2024	9001436	\$4,975.00
MEHRNAZ DAVOUDI	RFND-SB0646911/SB0646914/SB0646917/SB0646918	05/03/2024	106615	\$1,432.00
TOTAL GENERAL FUND				\$235,883.73
1005100 - CITY COUNCIL				
US BANK	CLOSED SESSION	05/03/2024	106601	\$180.22
US BANK	CLOSED SESSION	05/03/2024	106601	\$187.66
TOTAL CITY COUNCIL				\$367.88
1005150 - CITY CLERK				
US BANK	TRASH BAGS	05/03/2024	106601	\$84.34
US BANK	IIMC CONFERENCE TRAVEL	05/03/2024	106601	\$301.48
US BANK	ELECTION MATERIALS	05/03/2024	106601	\$299.64
US BANK	STORAGE BAGS	05/03/2024	106601	\$23.72
US BANK	EMAIL ENCRYPTION	05/03/2024	106601	\$57.50
US BANK	CCAC CONFERENCE REGISTRATION	05/03/2024	106601	\$650.00
US BANK	MINUTES	05/03/2024	106601	\$50.25
CORODATA RECORDS MANAGEMENT, INC	MAR 24-STORAGE/SHREDDING	04/25/2024	106574	\$1,070.92
KFORCE INC.	TEMP SERVICES-02/29/24-CLK	04/25/2024	9001419	\$500.00
KFORCE INC.	TEMP SERVICES-04/04/24-CLK	04/25/2024	9001419	\$640.00
KFORCE INC.	TEMP SERVICES-04/11/24-CLK	04/25/2024	9001419	\$280.00
TOTAL CITY CLERK				\$3,957.85

1005200 - CITY MANAGER

US BANK	CARDS FOR STAFF	05/03/2024	106601	\$51.28
US BANK	TONER	05/03/2024	106601	\$103.19
US BANK	OFFICE SUPPLIES	05/03/2024	106601	\$30.44
US BANK	BUSINESS CARDS	05/03/2024	106601	\$47.83
EMANUELS JONES AND ASSOCIATES	DEC 23-LOBBYING CONSULTING SERVICES	04/24/2024	9001413	\$518.40
CARRIER JOHNSON	FEB 24-PARKING STUDY	04/25/2024	106572	\$1,645.00

TOTAL CITY MANAGER**\$2,396.14****1005250 - LEGAL SERVICES**

BEST BEST & KRIEGER LLP	NOV 23-ELECTIONS COUNSEL SRVC	05/03/2024	106598	\$442.50
-------------------------	-------------------------------	------------	--------	----------

TOTAL LEGAL SERVICES**\$442.50****1005300 - FINANCE**

WILLDAN	MAR 24- FEE STUDY & COST ALLOCATION PLAN	04/25/2024	9001425	\$475.00
HDL COREN & CONE	APR-JUN 24-CONTRACT SRVC PROPERTY TAX	05/03/2024	9001434	\$3,747.50
AMAZON.COM SALES, INC	INV:13PP-HXDF-XJFC-ADHESIVE DESK DRAWER TRAY	04/25/2024	9001415	\$29.34
DAVIS FARR, LLP	FY 23-34-ANNUAL AUDIT SERVICES	05/03/2024	106606	\$7,400.00
CALIFORNIA BOARD OF ACCOUNTANCY	CPA EXAM APPLICATION FEE	05/03/2024	106602	\$100.00

TOTAL FINANCE**\$11,751.84****1005350 - SUPPORT SERVICES**

STAPLES CONTRACT & COMMERCIAL	PAPER	05/03/2024	106623	\$450.17
STAPLES CONTRACT & COMMERCIAL	AIR DUSTER/PENS/DESK CALENDAR	04/25/2024	106589	\$51.51
STAPLES CONTRACT & COMMERCIAL	PAPER	04/25/2024	106589	\$297.38
AMAZON.COM SALES, INC	INV:13PP-HXDF-XJFC-PAPER PLATES/BOWLS/FORKS/SPOONS	04/25/2024	9001415	\$163.17
AMAZON.COM SALES, INC	INV:13PP-HXDF-XJFC-SIGN HOLDERS	04/25/2024	9001415	\$39.65
AMAZON.COM SALES, INC	INV:13PP-HXDF-XJFC-COFFEE CREAMER/PODS/SUGAR	04/25/2024	9001415	\$121.39

TOTAL SUPPORT SERVICES**\$1,123.27****1005400 - HUMAN RESOURCES**

DEPARTMENT OF JUSTICE	MAR 24-FINGERPRINT APP	04/25/2024	106577	\$192.00
US BANK	STAR AWARD	05/03/2024	106601	\$138.42
US BANK	COUNCIL SNACKS	05/03/2024	106601	\$231.36
ALTA LANGUAGE SERVICES, INC	LANGUAGE TEST	05/03/2024	9001428	\$68.00

TOTAL HUMAN RESOURCES**\$629.78****1005450 - INFORMATION SERVICES**

COX COMMUNICATIONS INC	0013410039730701-04/19/24-05/18/24	05/03/2024	106604	\$321.49
US BANK	CONSTANT CONTACT	05/03/2024	106601	\$86.00
US BANK	CD CASES/SCREEN PROTECTORS/BATTERIES/LAPTOP CAS	05/03/2024	106601	\$359.00
US BANK	COMPUTER SPEAKERS	05/03/2024	106601	\$105.24
US BANK	FS PHONE EQUIPMENT	05/03/2024	106601	\$359.72
AMAZON.COM SALES, INC	INV:13PP-HXDF-XJFC-HOTLINE AUTO DIALER	04/25/2024	9001415	\$65.13
AMAZON.COM SALES, INC	INV:13PP-HXDF-XJFC-PHONE MOUNT/PLUG CONNECTOR	04/25/2024	9001415	\$34.68
AMAZON.COM SALES, INC	INV:13PP-HXDF-XJFC-KEYBOARD	04/25/2024	9001415	\$190.25
AMAZON.COM SALES, INC	INV:13PP-HXDF-XJFC-LINEMANS TEST SET	04/25/2024	9001415	\$119.20
AMAZON.COM SALES, INC	INV:13PP-HXDF-XJFC-CABNT/PWR SRTP/ETHERNET SWITCH	04/25/2024	9001415	\$387.31

TOTAL INFORMATION SERVICES**\$2,028.02****1005550 - PLANNING**

OFFICE DEPOT INC	FOLDERS/PENS/PRESSBOARD	05/03/2024	106618	\$113.46
CENTRAL SQUARE	TRAKIT - ANNUAL MAINT 07/01/23-06/30/24	04/25/2024	106573	\$28,570.17

				TOTAL PLANNING	\$28,683.63
1005590 - CODE ENFORCEMENT					
VERIZON WIRELESS-SD	442224168 - 02/24/24-03/23/24	04/25/2024	106592		\$139.01
DATATICKET INC.	MAR 24-PARKING CITATION SERVICES	05/03/2024	106605		\$724.71
DATATICKET INC.	MAR 23-PARKING CITATION SERVICES	05/03/2024	106605		\$1,120.80
US BANK	OFFICE SUPPLIES	05/03/2024	106601		\$123.82
US BANK	WIPER FLUID	05/03/2024	106601		\$6.51
DIAMOND MMP, INC.	PARKING CITATION NOTICE	04/25/2024	9001420		\$2,336.29
				TOTAL CODE ENFORCEMENT	\$4,451.14
1006110 - LAW ENFORCEMENT					
SAN DIEGO COUNTY SHERIFF'S DEPT.	MAR 24-LAW ENFORCEMENT	05/03/2024	106621		\$400,004.51
				TOTAL LAW ENFORCEMENT	\$400,004.51
1006120 - FIRE DEPARTMENT					
L. N. CURTIS & SONS INC	PULLEYS/BELT/DUFFEL BAG/PAD/RAPPEL	04/25/2024	106583		\$1,263.79
NAPA AUTO PARTS INC	DEISEL EXHAUST FLUID	04/25/2024	106585		\$64.59
NAPA AUTO PARTS INC	TIRE WET FOAM/DETAIL SPRAY/WAX POLISH	04/25/2024	106585		\$133.50
REGIONAL COMMS SYS, MS 056 - RCS	MAR 24- SHERIFF RADIOS	04/25/2024	106587		\$769.50
REGIONAL COMMS SYS, MS 056 - RCS	MAR 24-FIRE RADIOS	04/25/2024	106587		\$1,368.00
REGIONAL COMMS SYS, MS 056 - RCS	MAR 24-CAP CODE	04/25/2024	106587		\$32.50
ALLSTAR FIRE EQUIPMENT, INC	REDZONE PARTICULATE BLOCKING HOOD	04/25/2024	106570		\$1,267.93
US BANK	TONER - FS	05/03/2024	106601		\$27.67
US BANK	FS SUPPLIES	05/03/2024	106601		\$425.74
US BANK	FS SUPPLIES	05/03/2024	106601		\$36.96
US BANK	FS SUPPLIES	05/03/2024	106601		\$105.05
US BANK	FS BATTERIES	05/03/2024	106601		\$276.34
US BANK	FS VACUUM	05/03/2024	106601		\$217.49
US BANK	FLOOD LIGHT	05/03/2024	106601		\$638.30
US BANK	MAILBOX PEDESTAL	05/03/2024	106601		\$130.50
US BANK	CONNECTOR KIT	05/03/2024	106601		\$65.24
US BANK	F150 BRAKE REPAIR	05/03/2024	106601		\$1,069.63
US BANK	TIP LIGHT	05/03/2024	106601		\$638.30
ACE UNIFORMS LLC	BOOTS	05/03/2024	9001426		\$357.21
ACE UNIFORMS LLC	HATS/PATCHES	05/03/2024	9001426		\$1,161.11
ACE UNIFORMS LLC	ALTERATIONS	04/25/2024	9001414		\$122.32
ACE UNIFORMS LLC	PATCH/SEWING	04/25/2024	9001414		\$212.20
KATIE STRICKLAND	REIMB-ICC FIRE INSPECTOR 1-02/12/24-02/29/24	05/03/2024	106613		\$230.00
SOUTHERN CALIFORNIA FIRE PREVENTION	STATUTES AND REGULATIONS	04/25/2024	106588		\$300.00
				TOTAL FIRE DEPARTMENT	\$10,913.87
1006130 - ANIMAL CONTROL					
HABITAT PROTECTION, INC	APR 24- DEAD ANIMAL REMOVAL	04/25/2024	9001417		\$45.00
HABITAT PROTECTION, INC	APR 24- DEAD ANIMAL REMOVAL	05/03/2024	9001433		\$145.00
				TOTAL ANIMAL CONTROL	\$190.00
1006170 - MARINE SAFETY					
US BANK	HARDWARE FOR SIGNAGE	05/03/2024	106601		\$18.12
US BANK	TRAINING SUPPLIES	05/03/2024	106601		\$24.88
US BANK	ROPES	05/03/2024	106601		\$206.32
US BANK	PICTURE FRAME	05/03/2024	106601		\$40.19
CULLIGAN OF SAN DIEGO	APR 24- WATER-MS	04/25/2024	106575		\$56.89
WASHED OUT PRESSURE WASHING	CLEANING LIFEGUARD TOWERS	05/03/2024	106626		\$1,116.00
				TOTAL MARINE SAFETY	\$1,462.40

1006510 - ENGINEERING

VERIZON WIRELESS-SD	362455526 - 03/02/24-04/01/24	04/25/2024	106592	\$53.17
US BANK	ARCGIS LOGIN (IT)	05/03/2024	106601	\$58.16
US BANK	APWA LUNCH MEETING	05/03/2024	106601	\$45.00
MOHAMMAD SAMMAK	REIMB-ENGINEER LUNCHEON	05/03/2024	106617	\$19.20
ARIA ASGHARZADEH	REIMB-FISH & WILDLIFE ADMIN FEE	05/03/2024	106596	\$52.50

TOTAL ENGINEERING**\$228.03****1006520 - ENVIRONMENTAL SERVICES**

VERIZON WIRELESS-SD	362455526 - 03/02/24-04/01/24	04/25/2024	106592	\$53.17
MISSION LINEN & UNIFORM INC	UNIFORM SERVICES FOR PUBLIC WORKS	05/03/2024	106616	\$14.82
MISSION LINEN & UNIFORM INC	UNIFORM SERVICES FOR PUBLIC WORKS	04/25/2024	106584	\$14.81
DOG WASTE DEPOT	DOG WASTE BAGS	04/25/2024	106579	\$140.05
DOG WASTE DEPOT	DOG WASTE BAGS	04/25/2024	106579	\$2,415.55

TOTAL ENVIRONMENTAL SERVICES**\$2,638.40****1006530 - STREET MAINTENANCE**

VERIZON WIRELESS-SD	362455526 - 03/02/24-04/01/24	04/25/2024	106592	\$53.17
MISSION LINEN & UNIFORM INC	UNIFORM SERVICES FOR PUBLIC WORKS	05/03/2024	106616	\$24.06
MISSION LINEN & UNIFORM INC	UNIFORM SERVICES FOR PUBLIC WORKS	04/25/2024	106584	\$24.07
DIXIELINE LUMBER CO INC	GLOVES/UTILITY KNIFE	04/25/2024	106578	\$90.97
DIXIELINE LUMBER CO INC	SCISSORS/SCRAPER/TRASH CAN	05/03/2024	106610	\$167.98
DIXIELINE LUMBER CO INC	TRASH CANS/PUSH BROOM HEAD	05/03/2024	106610	\$195.39
DIXIELINE LUMBER CO INC	GLOVES	05/03/2024	106610	\$62.60
DIXIELINE LUMBER CO INC	PAINT ROLLER/CUTOFF WHEEL/DIAMOND BLADE	05/03/2024	106610	\$73.31
SDG&E CO INC	02/07/24-04/05/24-UTILITIES	05/03/2024	106622	(\$59.65)
SDG&E CO INC	03/07/24-04/05/24-UTILITIES	05/03/2024	106622	\$544.20
BOOT WORLD, INC.	BOOTS	05/03/2024	106599	\$193.91
WEST COAST ARBORISTS, INC.	03/19/24-03/22/24- CITY-WIDE TREE MAINTENANC	05/03/2024	106627	\$3,500.00
US BANK	PLASTIC SHED	05/03/2024	106601	\$1,184.17
US BANK	WHITewater BOULDER	05/03/2024	106601	\$134.30
BILL SMITH FOREIGN CAR SERVICE INC	STARTER REPLACE	04/25/2024	106571	\$402.08
BILL SMITH FOREIGN CAR SERVICE INC	OIL CHANGE/FILTER	04/25/2024	106571	\$69.85

TOTAL STREET MAINTENANCE**\$6,660.41****1006540 - TRAFFIC SAFETY**

VERIZON WIRELESS-SD	362455526 - 03/02/24-04/01/24	04/25/2024	106592	\$37.98
SDG&E CO INC	02/07/24-04/05/24-UTILITIES	05/03/2024	106622	\$50.42
SDG&E CO INC	03/07/24-04/05/24-UTILITIES	05/03/2024	106622	\$496.50
DEPARTMENT OF TRANSPORTATION	JAN-MAR 24-COST SHARE AGMT I-5 TRAFFIC SIGNAL	05/03/2024	106608	\$172.06
DEPARTMENT OF TRANSPORTATION	JAN-MAR 24-COST SHARE AGMT I-5 TRAFFIC SIGNAL	05/03/2024	106608	\$1,320.16
ALL CITY MANAGEMENT SERVICES, INC	03/31/24-04/13/24- CROSSING GUARD SERVICES	05/03/2024	9001427	\$5,946.00

TOTAL TRAFFIC SAFETY**\$8,023.12****1006560 - PARK MAINTENANCE**

VERIZON WIRELESS-SD	362455526 - 03/02/24-04/01/24	04/25/2024	106592	\$75.95
MISSION LINEN & UNIFORM INC	UNIFORM SERVICES FOR PUBLIC WORKS	05/03/2024	106616	\$17.59
MISSION LINEN & UNIFORM INC	UNIFORM SERVICES FOR PUBLIC WORKS	04/25/2024	106584	\$17.58
DIXIELINE LUMBER CO INC	WIRE CONNECTOR	04/25/2024	106578	\$8.79
DIXIELINE LUMBER CO INC	GLOVES	05/03/2024	106610	\$23.47
DIXIELINE LUMBER CO INC	LAMP/OUTLET ADAPTER	05/03/2024	106610	\$39.89
DIXIELINE LUMBER CO INC	FIBERGLASS FILLER	05/03/2024	106610	\$24.46
DIXIELINE LUMBER CO INC	PLIERS/SCREWS	05/03/2024	106610	\$16.62
DIXIELINE LUMBER CO INC	SCREWS	05/03/2024	106610	\$15.25
DIXIELINE LUMBER CO INC	SIGNS	05/03/2024	106610	\$25.43

RANCHO SANTA FE SECURITY SYS INC	MAY 24-ALARM MONITORING	05/03/2024	106620	\$331.20
US BANK	PAINT	05/03/2024	106601	\$30.79
AA FARNSWORTH'S BACKFLOW SERVICES	ANNUAL BACKFLOW TEST	05/03/2024	106594	\$713.75
EMBROIDERY IMAGE	POLO-PW	04/25/2024	106580	\$114.75
BILL SMITH FOREIGN CAR SERVICE INC	TRANSMISSION/FLYWHEEL ASSB/OIL SEAL	04/25/2024	106571	\$1,280.76
THE HOME DEPOT PRO	BLEACH/LINERS	04/25/2024	106591	\$590.35

TOTAL PARK MAINTENANCE**\$3,326.63****1006570 - PUBLIC FACILITIES**

DIXIELINE LUMBER CO INC	PAINT ROLLER/PAINT BRUSH	04/25/2024	106578	\$20.52
DIXIELINE LUMBER CO INC	LIGHT SOCKET/BIT TIP HOLDER	05/03/2024	106610	\$40.39
DIXIELINE LUMBER CO INC	PLUMBING TEST	05/03/2024	106610	\$6.16
SDG&E CO INC	02/07/24-04/05/24-UTILITIES	05/03/2024	106622	\$1,721.72
SDG&E CO INC	03/07/24-04/05/24-UTILITIES	05/03/2024	106622	\$5,832.22
US BANK	VENTILATION FAN	05/03/2024	106601	\$96.79
US BANK	FLOOR MATS FOR CHEVY COLORADO	05/03/2024	106601	\$96.89
US BANK	BATHROOM FAN	05/03/2024	106601	\$10.88
US BANK	ADJUSTABLE TWIST HOSE NOZZLE	05/03/2024	106601	\$15.21
US BANK	LED LIGHTS	05/03/2024	106601	\$273.56
US BANK	BATHROOM FAUCET	05/03/2024	106601	\$254.29
LALLEY CONSTRUCTION	AS-NEEDED REPAIR-OUTDOOR SHWR/DOOR	05/03/2024	106614	\$455.00
LALLEY CONSTRUCTION	ON-CALL AS-NEEDED REPAIR SERVI	05/03/2024	106614	\$845.00
SYMONS FIRE PROTECTION	2 QTR- FIRE SUPPRESSION EQUIPMENT INSPECTION	05/03/2024	106624	\$1,110.00
SYMONS FIRE PROTECTION	Q1- FIRE SUPPRESSION EQUIPMENT	04/25/2024	106590	\$1,110.00
CINTAS CORPORATION NO. 2	FIRST AID SUPPLIES-PW	05/03/2024	106603	\$81.55
HABITAT PROTECTION, INC	APR-24- BEE/WASP REMOVAL	05/03/2024	9001433	\$1,495.00

TOTAL PUBLIC FACILITIES**\$13,465.18****1007100 - COMMUNITY SERVICES**

BAKER IRON WORKS INC	SCULPTURES/MOUNTING	05/03/2024	106597	\$4,893.75
STAPLES CONTRACT & COMMERCIAL	AIR DUSTER/PENS/DESK CALENDAR	04/25/2024	106589	\$7.06
US BANK	CITY-COUNTY COM & MARK ASSOC	05/03/2024	106601	\$400.00

TOTAL COMMUNITY SERVICES**\$5,300.81****1007110 - GF-RECREATION**

US BANK	LITTLE LIBRARY SIGN FOR LC	05/03/2024	106601	\$54.94
US BANK	TAPE AND ZIP TIES	05/03/2024	106601	\$39.09
EMBROIDERY IMAGE	STAFF UNIFORMS-PARK & REC	04/25/2024	106580	\$509.38
BUSINESS OFFICE OUTFITTERS	RECREATION DEPARTMENT FURNITURE	05/03/2024	106600	\$3,366.11

TOTAL GF-RECREATION**\$3,969.52****1205460 - SELF INSURANCE RETENTION**

US BANK	PARMA HOTEL	05/03/2024	106601	\$915.48
GEORGE HILLS COMPANY, INC.	GL CLAIMS SERVICES	05/03/2024	9001432	\$756.90

TOTAL SELF INSURANCE RETENTION**\$1,672.38****1355450 - ASSET REPLACEMENT-INFO SYS**

DELL MARKETING L.P.	LAPTOP	05/03/2024	106607	\$2,262.69
---------------------	--------	------------	--------	------------

TOTAL ASSET REPLACEMENT-INFO SYS**\$2,262.69****1356120 - ASSET REPLACEMENT-FIRE**

FIRE STATION OUTFITTERS LLC	RECLINERS-FS	04/25/2024	106581	\$1,903.13
-----------------------------	--------------	------------	--------	------------

TOTAL ASSET REPLACEMENT-FIRE**\$1,903.13****1356170 - ASSET REPLACEMENT-MARN SFTY**

US BANK	PAINT FOR DIVE TRAILER	05/03/2024	106601	\$57.25
---------	------------------------	------------	--------	---------

TOTAL ASSET REPLACEMENT-MARN SFTY**\$57.25**

1605360 - OPEB OBLIGATION

MIDAMERICA	MAY 24	05/03/2024	9001435	\$8,225.00
------------	--------	------------	---------	------------

TOTAL OPEB OBLIGATION**\$8,225.00****2037510 - HIGHWAY 101 LANDSC #33**

SDG&E CO INC	03/07/24-04/05/24-UTILITIES	05/03/2024	106622	\$2,633.18
--------------	-----------------------------	------------	--------	------------

TOTAL HIGHWAY 101 LANDSC #33**\$2,633.18****2117600 - STREET LIGHTING DISTRICT**

VERIZON WIRELESS-SD	362455526 - 03/02/24-04/01/24	04/25/2024	106592	\$15.19
---------------------	-------------------------------	------------	--------	---------

SDG&E CO INC	02/07/24-04/05/24-UTILITIES	05/03/2024	106622	\$9,245.93
--------------	-----------------------------	------------	--------	------------

TOTAL STREET LIGHTING DISTRICT**\$9,261.12****2135550 - DEVELOPER PASS-THRU- PLANNING**

PAMELA ELLIOTT LANDSCAPE ARCHITECT	MARCH 2024	04/25/2024	9001421	\$350.00
------------------------------------	------------	------------	---------	----------

PAMELA ELLIOTT LANDSCAPE ARCHITECT	MARCH 2024	04/25/2024	9001421	\$350.00
------------------------------------	------------	------------	---------	----------

PAMELA ELLIOTT LANDSCAPE ARCHITECT	MARCH 2024	04/25/2024	9001421	\$350.00
------------------------------------	------------	------------	---------	----------

PAMELA ELLIOTT LANDSCAPE ARCHITECT	MARCH 2024	04/25/2024	9001421	\$350.00
------------------------------------	------------	------------	---------	----------

PAMELA ELLIOTT LANDSCAPE ARCHITECT	MARCH 2024	04/25/2024	9001421	\$350.00
------------------------------------	------------	------------	---------	----------

PAMELA ELLIOTT LANDSCAPE ARCHITECT	MARCH 2024	04/25/2024	9001421	\$350.00
------------------------------------	------------	------------	---------	----------

PAMELA ELLIOTT LANDSCAPE ARCHITECT	MARCH 2024	04/25/2024	9001421	\$350.00
------------------------------------	------------	------------	---------	----------

PAMELA ELLIOTT LANDSCAPE ARCHITECT	MARCH 2024	04/25/2024	9001421	\$350.00
------------------------------------	------------	------------	---------	----------

PAMELA ELLIOTT LANDSCAPE ARCHITECT	MARCH 2024	04/25/2024	9001421	\$350.00
------------------------------------	------------	------------	---------	----------

PAMELA ELLIOTT LANDSCAPE ARCHITECT	MARCH 2024	04/25/2024	9001421	\$350.00
------------------------------------	------------	------------	---------	----------

PAMELA ELLIOTT LANDSCAPE ARCHITECT	APRIL 2024	04/25/2024	9001421	\$350.00
------------------------------------	------------	------------	---------	----------

PAMELA ELLIOTT LANDSCAPE ARCHITECT	APRIL 2024	04/25/2024	9001421	\$350.00
------------------------------------	------------	------------	---------	----------

CONSTRUCTION TESTING & ENGINEERING, INC.	GEOTECHNICAL REVIEW FOR THE LAS BRISAS TE23-002	04/25/2024	9001424	\$610.00
--	---	------------	---------	----------

TOTAL DEVELOPER PASS-THRU- PLANNING**\$4,810.00****2146120 - FIRE MITIGATION FEES**

LINEGEAR FIRE & RESCUE EQUIPMENT	JACKETS/PANTS	04/25/2024	106582	\$2,533.62
----------------------------------	---------------	------------	--------	------------

TOTAL FIRE MITIGATION FEES**\$2,533.62****2196110 - COPS PROGRAM**

SAN DIEGO COUNTY SHERIFF'S DEPT.	MAR 24-LAW ENFORCEMENT	05/03/2024	106621	\$12,051.99
----------------------------------	------------------------	------------	--------	-------------

TOTAL COPS PROGRAM**\$12,051.99****2505570 - COASTAL BUSINESS/VISITORS**

US BANK	EGG HUNT COLORING POSTER	05/03/2024	106601	\$75.00
---------	--------------------------	------------	--------	---------

US BANK	EGG HUNT SUPPLIES	05/03/2024	106601	\$77.43
---------	-------------------	------------	--------	---------

US BANK	EGG HUNT SUPPLIES	05/03/2024	106601	\$135.22
---------	-------------------	------------	--------	----------

US BANK	EGG HUNT SUPPLIES	05/03/2024	106601	\$213.87
---------	-------------------	------------	--------	----------

US BANK	EGG HUNT SUPPLIES	05/03/2024	106601	\$171.89
---------	-------------------	------------	--------	----------

US BANK	EGG HUNT SUPPLIES	05/03/2024	106601	\$233.73
---------	-------------------	------------	--------	----------

TOTAL COASTAL BUSINESS/VISITORS**\$907.14****2556180 - CAMP PROGRAMS**

US BANK	SCHEDULING PROGRAM	05/03/2024	106601	\$12.00
---------	--------------------	------------	--------	---------

TOTAL CAMP PROGRAMS**\$12.00****2706120 - PUBLIC SAFETY- FIRE**

US BANK	LED POWER SUPPLY/MDC NCDJPA	05/03/2024	106601	\$130.24
---------	-----------------------------	------------	--------	----------

US BANK	MDC SUPPLIES	05/03/2024	106601	\$159.37
---------	--------------	------------	--------	----------

US BANK	FIRE IPAD PROTECTIVE CASES/MDC NCDJPA	05/03/2024	106601	\$1,744.73
---------	---------------------------------------	------------	--------	------------

GAETKE MEDICAL CORPORATION	FIRE EMPLOYEE PHYSICALS (10/13/2023)	05/03/2024	106612	\$10,000.00
----------------------------	--------------------------------------	------------	--------	-------------

TOTAL PUBLIC SAFETY- FIRE**\$12,034.34****2706170 - PUBLIC SAFETY- MARINE SAFETY**

US BANK	CSA.17 SHARPS CONTAINER	05/03/2024	106601	\$19.32
---------	-------------------------	------------	--------	---------

TOTAL PUBLIC SAFETY- MARINE SAFETY**\$19.32****459 - MISC. CAPITAL PROJECTS**

QUALITY CONSTRUCTION & ENGINEERING, INC.	9362.23 FY23 PAVEMENT MAINTENCE	04/25/2024	106593	(\$1,236.65)
--	---------------------------------	------------	--------	--------------

TOTAL MISC. CAPITAL PROJECTS**(\$1,236.65)****4595450 - MISC.CAPITALPROJECTS-IS**

US BANK	9408.00 COUNCIL CHAMBER UPGRADES	05/03/2024	106601	\$945.86
AMAZON.COM SALES, INC	INV:13PP-HXDF-XJFC-SMART TV	04/25/2024	9001415	\$982.56
AMAZON.COM SALES, INC	INV:13PP-HXDF-XJFC-HDMI CABLE/DISPLAY PORT	04/25/2024	9001415	\$63.06
AMAZON.COM SALES, INC	INV:13PP-HXDF-XJFC-TOUCH SCREEN MONITOR	04/25/2024	9001415	\$276.85

TOTAL MISC.CAPITALPROJECTS-IS**\$2,268.33****4596510 - MISC.CAPITALPROJECTS-ENG**

UT SAN DIEGO - NRTH COUNTY	NTC-BID NO:2024-04	05/03/2024	106625	\$785.95
QUALITY CONSTRUCTION & ENGINEERING, INC.	9362.23 FY23 PAVEMENT MAINT CO	04/25/2024	106593	\$21,229.34
QUALITY CONSTRUCTION & ENGINEERING, INC.	9362.23 FY23 PAVEMENT MAINTENA	04/25/2024	106593	\$3,503.66

TOTAL MISC.CAPITALPROJECTS-ENG**\$25,518.95****5097700 - SANITATION**

VERIZON WIRELESS-SD	362455526 - 03/02/24-04/01/24	04/25/2024	106592	\$15.19
MISSION LINEN & UNIFORM INC	UNIFORM SERVICES FOR PUBLIC WORKS	05/03/2024	106616	\$9.25
MISSION LINEN & UNIFORM INC	UNIFORM SERVICES FOR PUBLIC WORKS	04/25/2024	106584	\$9.26

TOTAL SANITATION**\$33.70****6527820 - SUCCESSOR AGENCY**

COMPUTERSHARE CORPORATE TRUST	INTREST/PRINCIPAL 2017 BOND-06/01	04/25/2024	9001416	\$33,099.36
COMPUTERSHARE CORPORATE TRUST	INTREST/PRINCIPAL 2017 BOND-06/01	04/25/2024	9001416	\$67,800.00
COMPUTERSHARE CORPORATE TRUST	INTREST/PRINCIPAL 2017 BOND-06/01	04/25/2024	9001416	(\$104.32)

TOTAL SUCCESSOR AGENCY**\$100,795.04****REPORT TOTAL:****\$933,661.19**



STAFF REPORT CITY OF SOLANA BEACH

TO: Honorable Mayor and City Councilmembers
FROM: Alyssa Muto, City Manager
MEETING DATE: May 22, 2024
ORIGINATING DEPT: Finance
SUBJECT: Report on Changes Made to the General Fund Adopted Budget for Fiscal Year 2023-24

BACKGROUND:

Staff provides a report at each Council meeting that lists changes made to the current Fiscal Year (FY) General Fund Adopted Budget. The information provided in this Staff Report lists the changes made through May 8, 2024.

DISCUSSION:

The following table reports the revenues, expenditures, and transfers for 1) the Adopted General Fund Budget approved by Council on June 28, 2023 (Resolution 2023-089), 2) prior year purchase order carryover adjustments, and 3) any resolutions passed by Council that amended the Adopted General Fund Budget.

GENERAL FUND - ADOPTED BUDGET PLUS CHANGES						
As of 05/08/2024						
General Fund - Operations						
Date	Action	Description	Revenues	Expenditures	Transfers from GF	Net Surplus
06/28/2023	Reso 2023-089	Adopted Budget	24,472,918	(23,078,124)	(980,000)	\$ 414,794
07/01/2023	System Generated	FY 2023 GF PO Carryover		(19,590)		395,204
09/27/2023	Reso 2023-113	Ord 531 Training/Diversion Program		(10,000)		385,204
11/29/2023	Reso 2023-128	Engineering Survey Services		(100,000)		285,204
03/13/2024	Reso 2024-027	STC Traffic Inc (Pedestrian Crossing)		(20,000)		265,204
03/27/2024	Reso 2024-015	La Colonia Master Plan Update			(70,000)	195,204
04/10/2024	Reso 2024-039	Mid-Year Adjustments for FY 2024	702,072	(21,229)		876,047
						876,047
General Fund - Measure S						
Date	Action	Description	Revenues	Expenditures	Transfers from GF	Net Surplus
06/28/2023	Reso 2023-089	Adopted Budget	4,400,000	(1,124,000)	(733,400)	\$ 2,542,600
04/10/2024	Reso 2024-039	Mid-Year Adjustments for FY 2024	200,000			2,742,600
						2,742,600
Combined General Fund Net Surplus						\$ 3,618,647

COUNCIL ACTION:

CEQA COMPLIANCE STATEMENT:

Not a project as defined by CEQA.

FISCAL IMPACT:

N/A

WORK PLAN:

N/A

OPTIONS:

- Receive the report.
- Do not accept the report.

DEPARTMENT RECOMMENDATION:

Staff recommends that the City Council receive the report listing changes made to the FY 2023-2024 General Fund Adopted Budget.

CITY MANAGER'S RECOMMENDATION:

Approve Department Recommendation



Alyssa Muto, City Manager



STAFF REPORT CITY OF SOLANA BEACH

TO: Honorable Mayor and City Councilmembers
FROM: Alyssa Muto, City Manager
MEETING DATE: May 22, 2024
ORIGINATING DEPT: Engineering Department
SUBJECT: **City Council Consideration of Resolutions 2024-046, 2024-047 and 2024-048 Approving the Preliminary Coastal Rail Trail Engineer’s Report for Fiscal Year 2024/25 and the Annual Levy and Collection of Assessments for the Solana Beach Coastal Rail Trail Maintenance District**

BACKGROUND:

In 2006, the City Council adopted a resolution forming the Solana Beach Coastal Rail Trail Maintenance District (District) under the provisions of the Landscape and Lighting Act of 1972, Division 15, Part 2, of the California Streets and Highways Code (1972 Act). The District was formed for the purpose of levying and collecting funds for the operation, maintenance, and servicing of landscaping, lighting and all appurtenant facilities related to the Coastal Rail Trail (CRT). In order to levy and collect an assessment in the District, it is necessary to notify the property owners of the City and conduct a Public Hearing. Staff is recommending the public hearing be held on June 12, 2024.

This item is presented to the City Council for the consideration of Resolution 2024-046 (Attachment 1) initiating proceedings for the District for Fiscal Year (FY) 2024/25, Resolution 2024-047 (Attachment 2) approving the Preliminary Engineer’s Report and Resolution 2024-048 (Attachment 3) setting a time and place for a Public Hearing.

DISCUSSION:

The District’s major costs are for ongoing maintenance of the CRT. The maintenance items include landscaping, irrigation, trail maintenance and graffiti removal. The costs also include the utility charges for water use along the CRT. The District includes funds for capital replacement as well including future replacement of landscaping, irrigation, pedestrian/bike path and hardscape items. The capital replacement costs also include an operating reserve of approximately 10% of the direct maintenance costs.

CITY COUNCIL ACTION:

The District's assessment methodology uses an Equivalent Benefit Unit (EBU) System. The EBU method of apportioning benefit is typically viewed as the most appropriate and equitable assessment methodology for districts formed under the 1972 Act. The EBU for the proposed District establishes the single-family detached residential unit as the basic unit, representing 1.0 EBU. The following summarizes the EBU application by land use:

<u>Land Use</u>	<u>EBU</u>
Single-Family Residential	1.0 per parcel
Residential Condominium	1.0 per dwelling unit
Multi-Family Residential	0.75 per dwelling unit
Planned Residential Development	1.0 per proposed unit
Commercial/Industrial	1.0 per parcel
Vacant Single-Family Residential	1.0 per parcel
Vacant Multi-Family Residential	0.75 per parcel
Vacant Commercial/Industrial	1.0 per parcel

The methodology identifies parcels that are exempt from the proposed District. They include, but are not limited to, parcels identified as public streets, roadways, dedicated public easements, open space and rights-of-way. These properties, as well as other publicly owned properties such as schools, fire stations, post offices and community centers are considered to receive little or no benefit from the improvements of the proposed District.

In addition to assigning properties an EBU by land type, the assessment methodology utilizes three zones based on the proximity of parcels to the CRT. Properties located closest to the CRT will receive a greater special benefit than those properties that are located further away from the trail. A factor is applied to each of the zones according to their locations. The three zones are as follows:

Zone 1:

This zone includes all properties generally located within a few blocks and closest to the CRT. The properties are located between the east side of Acacia Avenue, the east side of South Sierra Avenue and the west side of Rios Avenue (see the assessment boundary map in the Engineer's Report). Parcels in this zone are assessed the EBU amounts based on land use and then multiplied by a factor of three.

Zone 2:

This zone includes all properties that are generally located on the west side of Acacia Avenue, the west side of South Sierra Avenue and those properties located between the east side of Rios Avenue and west of Interstate 5. Parcels in this zone are assessed the EBU amounts based on land use and then multiplied by a factor of two.

Zone 3:

This zone includes properties located east of Interstate 5. Parcels in this zone are assessed the EBU amounts based on land use and then multiplied by a factor of 0.5.

At the formation of the District, the adopted Maximum Assessment formula included an annual Consumer Price Index for All Urban Consumers (CPI-U) adjustment that is not to exceed 2.00%. This Maximum Assessment annual adjustment adopted by the initial vote is not considered an increased assessment. Since the CPI-U for 2023 was 5.51%, the increase to the EBU charge from last year is 2.00%, which is the maximum allowed. The following shows the maximum assessment rates proposed to be levied in the Fiscal Year (FY) 2024/25 by land use:

Land Use Description	Per	Base Rate Zone 1	Base Rate Zone 2	Base Rate Zone 3
Single-Family Residential	Lot or Parcel	\$25.08	\$16.72	\$4.18
Residential Condominium	Dwelling Unit	\$25.08	\$16.72	\$4.18
Multi-Family Residential	Dwelling Unit	\$18.82	\$12.54	\$3.14
Planned Residential Development	Lot or Dwelling Unit	\$25.08	\$16.72	\$4.18
Commercial/Industrial	Parcel	\$25.08	\$16.72	\$4.18
Vacant Single-Family Residential	Parcel	\$25.08	\$16.72	\$4.18
Vacant Multi-Family Residential	Parcel	\$18.82	\$12.54	\$3.14
Vacant Commercial/Industrial	Parcel	\$25.08	\$16.72	\$4.18
Timeshare Units	1 week of ownership	\$ 0.00	\$ 0.00	\$0.00
Exempt Parcels	Parcel	\$ 0.00	\$ 0.00	\$0.00
Public Owned Parcels	Parcel	\$ 0.00	\$ 0.00	\$0.00

The 1972 Act requires the City Council to adopt a resolution annually directing the preparation and filing of an Annual Report and a Resolution of Intention to renew the annual assessments for the District. The resolutions declare the City Council's intention to levy and collect assessments and set the date of the public hearing at which the assessments will be levied. The law requires the assessment information to be submitted to the County by August 10th of each year.

Attachment 4 is the preliminary CRT Maintenance District Engineer's Report for FY 2024/25. The report contains an overview of the District; a description of the services and

improvements to be maintained; the proposed FY 2024/25 Budget; and the method of apportionment.

The City will notify the property owners about levying and collecting assessments in the Solana Beach Coastal Rail Trail Maintenance District by publishing a notice about the date of the Public Hearing (June 26, 2024) in the local paper.

CEQA COMPLIANCE STATEMENT:

Not a project as defined by CEQA.

FISCAL IMPACT:

The District began assessing a benefit charge in FY 2006/07. The CPI-U for 2023 was 5.51%. Since the maximum amount the assessment is allowed to increase each year is equal to the CPI-U but not greater than 2.00%, the assessments for FY 2024/25 are proposed to increase by 2.00% per Table 3 of the Report (and indicated on the previous page of this Staff Report). The amount of the Equivalent Benefit Unit for FY 2024/25 is \$8.36. This is \$0.18 more per EBU than last year's assessment and is consistent with the approval of the District by the vote of the property owners in January 2006.

Based on the above methodology and included in the Engineer's Report, the CRT is expected to receive \$84,177 in benefit charge revenues (total assessment amount). The total amount expected to be spent on the Coastal Rail Trail in FY 2024/25 is \$106,231. The shortfall of \$22,054, or the difference between the amount expected to be received (\$84,177) and the amount expected to be spent (\$106,231), will be covered by available projected reserves in the CRT fund of \$45,984 on July 1, 2024. The CRT fund should keep reserves equal to approximately 50% of the annual assessment amount. The proposed budget will reduce the CRT fund balance to approximately \$23,930 by June 30, 2025. This reserve will be under the 50% recommended maximum fund balance of \$42,089. In the future, additional funds will need to be appropriated from non-CRT funding sources to fully fund the maintenance of the Coastal Rail Trail and maintain the recommended operating reserves.

WORK PLAN:

Renewal of the CRT Maintenance District is consistent with the Fiscal Sustainability section of the City's Work Plan.

OPTIONS:

- Accept the Preliminary Coastal Rail Trail Maintenance District Engineer's Report for FY 2024/25, proceed with the annual levy of assessments and set the time and date for a public hearing to be held on June 26, 2024.

- Do not renew the CRT Maintenance District and fund cost for maintenance of the CRT through the General Fund.
- Provide direction.

DEPARTMENT RECOMMENDATION:

Staff recommends that the City Council:

1. Adopt Resolution 2024-046, initiating the proceedings for the annual levy of assessments within the Coastal Rail Trail Maintenance District for Fiscal Year 2024/25.
2. Adopt Resolution 2024-047, approving the Preliminary Engineer's Report for proceedings of the annual levy of assessments within Coastal Rail Trail Maintenance District.
3. Adopt Resolution 2024-048, declaring intention to provide for the annual levy and collection of assessments in Coastal Rail Trail Maintenance District and setting a time and date for a public hearing for June 26, 2024.

CITY MANAGER'S RECOMMENDATION:

Approve Department Recommendation.



Alyssa Muto, City Manager

Attachments:

1. Resolution 2024-046, Initiating Proceedings
2. Resolution 2024-047, Approving Preliminary Engineer's Report
3. Resolution 2024-048, Setting the Public Hearing
4. CRT Maintenance District Engineer's Report for FY 2024/25

RESOLUTION 2024-046

A RESOLUTION OF THE CITY COUNCIL OF THE CITY OF SOLANA BEACH, CALIFORNIA, INITIATING PROCEEDINGS FOR THE CITY OF SOLANA BEACH COASTAL RAIL TRAIL MAINTENANCE DISTRICT FOR FY 2024/25 AND FOR THE ANNUAL LEVY OF ASSESSMENTS WITHIN THE COASTAL RAIL TRAIL MAINTENANCE DISTRICT

WHEREAS, the City Council of the City of Solana Beach, California, by previous Resolutions formed and approved the maximum annual assessment rates for the City of Solana Beach Coastal Rail Trail Maintenance District (“District”), pursuant to the provisions of the *Landscaping and Lighting Act of 1972, Part 2, Division 15 of the California Streets and Highways Code (commencing with sections 22500)* (1972 Act); and

WHEREAS, the 1972 Act provides the City Council the authority to annually levy and collect assessments for the District on the San Diego County tax roll on behalf of the District to pay the maintenance, services, and operation of facilities and improvements related thereto; and

WHEREAS, the City has retained Koppel & Gruber Public Finance for the purpose of preparing and filing an engineer’s report (hereinafter referred to as the Engineer’s Report) with the City Clerk.

NOW, THEREFORE, the City Council of the City of Solana Beach, California, does resolve as follows:

1. That the above recitations are true and correct.
2. The City Council hereby appoints Koppel & Gruber Public Finance as the District Assessment Engineer and orders Koppel & Gruber Public Finance to prepare the Engineer’s Report concerning the District and the levy of assessments for Fiscal Year (FY) 2024/25, in accordance with *Chapter 1, Article 4, beginning with Section 22565* of the Act.

That Coastal Rail Trail Maintenance District Engineer’s Report for FY 2024/25, as presented, consists of the following:

- A description of the District boundary and improvements; and
- The Annual Budget (costs and expenses of services, operation and maintenance); and
- The method of apportionment for calculating the assessment for

each of the assessed parcels, lots and subdivisions of land for the property located within the CRT Maintenance District in proportion to the special benefits received and a roll containing the proposed levy amount for each assessed parcel within the CRT Maintenance District for FY 2024/25; and

- An exhibit showing the boundaries of the District.

Upon completion of the Engineer's Report, said Report shall be filed with the City Clerk, who shall submit the same to the City Council for its consideration pursuant to *Section 22586* of the Act.

3. The proposed improvements for the District include, but are not limited to: the ongoing maintenance, operation and servicing of landscaping and public lighting improvements that were installed as part of the construction of the City's Coastal Rail Trail. These improvements may also include all materials, equipment, utilities, labor, and appurtenant facilities related to those improvements. The Engineer's Report describes in more detail the items to be maintained and serviced.
4. The City Council hereby determines that to provide the improvements described in Section 3 of this resolution, it is necessary to levy and collect assessments against lots and parcels within the District.
5. The City Manager of the City of Solana Beach is hereby authorized and directed to take any and all action necessary and appropriate in connection with the annual levy and collection of assessments for the District.

PASSED AND ADOPTED this 22nd day of May 2024, at a Regular Meeting of the City Council of the City of Solana Beach, California by the following vote:

AYES: Councilmembers –
NOES: Councilmembers –
ABSTAIN: Councilmembers –
ABSENT: Councilmembers –

LESA HEEBNER, Mayor

APPROVED AS TO FORM:

ATTEST:

JOHANNA N. CANLAS, City Attorney

ANGELA IVEY, City Clerk

RESOLUTION 2024-047

A RESOLUTION OF THE CITY COUNCIL OF THE CITY OF SOLANA BEACH, CALIFORNIA, APPROVING THE PRELIMINARY ENGINEER'S REPORT FOR PROCEEDINGS FOR THE ANNUAL LEVY OF ASSESSMENTS WITHIN THE COASTAL RAIL TRAIL MAINTENANCE DISTRICT

WHEREAS, the City Council of the City of Solana Beach, California, pursuant to the terms of the "Landscaping and Lighting Act of 1972", being Division 15, Part 2 of the Streets and Highways Code of the State of California, did, by previous Resolution, initiate proceedings and ordered the preparation of an Engineer's Report for the annual levy of assessments within a special assessment district, such special assessment district known and designated as City of Solana Beach Coastal Rail Trail Maintenance District (Maintenance District); and

WHEREAS, pursuant to Section 22586 of the Streets and Highways Code, there has now been presented to this City Council the Engineer's Report as required by said Division 15 of the Streets and Highways Code and as previously directed by Resolution; and

WHEREAS, the City Council has carefully examined and reviewed the Preliminary Engineer's Report as presented, and is preliminarily satisfied with the Maintenance District, each and all the budget items and documents as set forth therein and is satisfied that the proposed assessments have been spread in accordance with the benefits received from the improvements to be maintained and services, as set forth in said Engineer's Report.

NOW, THEREFORE, the City Council of the City of Solana Beach, California, does resolve as follows:

1. That the above recitations are true and correct.
2. That the Coastal Rail Trail Maintenance District Engineer's Report for Fiscal Year 2024/25, as presented, consists of the following:
 - A description of the Maintenance District boundary and improvements; and
 - The Annual Budget (costs and expenses of services, operation and maintenance); and
 - The method of apportionment for calculating the assessment for each of the assessed parcels, lots, and subdivisions of land for the

property located within the Maintenance District in proportion to the special benefits received and a roll containing the proposed levy amount for each assessed parcel within the Maintenance District for Fiscal Year 2024/25; and

- An exhibit showing the boundaries of the District.
3. That the Engineer's Report is hereby preliminarily approved and ordered to be filed in the Office of the City Clerk as a permanent record and to remain open to public inspection.
 4. That the City Clerk shall certify to the passage and adoption of this Resolution and the minutes of this meeting shall so reflect the presentation of the Engineer's Report.

PASSED AND ADOPTED this 22nd day of May 2024, at a Regular Meeting of the City Council of the City of Solana Beach, California by the following vote:

AYES: Councilmembers –
NOES: Councilmembers –
ABSTAIN: Councilmembers –
ABSENT: Councilmembers –

LESA HEEBNER, Mayor

APPROVED AS TO FORM:

ATTEST:

JOHANNA N. CANLAS, City Attorney

ANGELA IVEY, City Clerk

RESOLUTION 2024-048

A RESOLUTION OF THE CITY COUNCIL OF THE CITY OF SOLANA BEACH, CALIFORNIA, DECLARING ITS INTENTION TO PROVIDE FOR THE ANNUAL LEVY AND COLLECTION OF ASSESSMENTS IN THE COASTAL RAIL TRAIL MAINTENANCE DISTRICT FOR FY 2024/25 AND SETTING A TIME AND PLACE FOR A PUBLIC HEARING THEREON

WHEREAS, the City Council of the City of Solana Beach, California, has previously formed a special assessment district pursuant to the terms of the "Landscaping and Lighting Act of 1972", being Division 15, Part 2 of the Streets and Highways Code of the State of California, such special assessment district known and designated as City of Solana Beach Coastal Rail Trail Maintenance District (the Maintenance District); and

WHEREAS, at this time, the City Council is desirous to take proceedings to provide for the annual levy of assessments for the next ensuing fiscal year to provide for costs and expenses necessary to pay for the maintenance of the improvements in said Maintenance District; and

WHEREAS, at the formation of the District, the adopted Maximum Assessment formula includes an annual Consumer Price Index for All Urban Consumers (CPI-U) adjustment not to exceed 2.00% and this annual adjustment adopted by the initial vote is not considered an increased assessment. The CPI-U for 2023 was 5.51%. Since the maximum amount the assessment is allowed to increase each year is 2.00%, the assessments per Equivalent Benefit Unit (EBU) for Fiscal Year 2024/25 are proposed to increase by 2.00%; and

WHEREAS, there has been presented and approved by this City Council the Engineer's Report, as required by law, and this City Council is desirous of continuing with the proceedings for said annual levy by adopting this Resolution of Intent pursuant to Streets and Highways Code Section 22587.

NOW, THEREFORE, the City Council of the City of Solana Beach, California, does resolve as follows:

1. That the above recitations are true and correct.
2. The public interest and convenience require, and the City Council does propose at this time, to levy assessments for the Maintenance District to provide for the financing of the operation, maintenance and servicing of certain improvements located within the Coastal Rail Trail including both

landscaping improvements and appurtenances and public lighting improvements and appurtenances.

The landscaping improvements and services to be maintained by the Maintenance District include, but are not limited to, landscaping, planting, ground cover, shrubbery, turf, trees, irrigation and drainage systems, hardscape, fixtures, sidewalks, fencing and other appurtenant items located along and adjacent to the City portion of the Coastal Rail Trail.

The public lighting improvements to be maintained and serviced include, but are not limited to, poles, fixtures, bulbs, conduits, conductors, equipment including guys, anchors, posts and pedestals, metering devices and appurtenant facilities as required to provide lighting along and within the Coastal Rail Trail.

3. That said works of improvement are of special benefit to the properties within the boundaries of said Maintenance District, which Maintenance District the legislative body previously declared to be the area specially benefited by said works of improvement, and for particulars, reference is made to the boundary map as previously approved by this legislative body, a copy of which is on file in the Office of the City Clerk and open for public inspection, and is designated by the name of this Maintenance District.
4. That the Engineers Report, as preliminarily approved by the legislative body, is on file with the City Clerk and open for public inspection. Reference is made to such Engineer's Report for a full and detailed description of the improvements to be installed and/or maintained, the boundaries of the Maintenance District, any zones therein and the proposed assessments upon assessable lots and parcels of land within the Maintenance District.
5. All costs and expenses of the works of maintenance and incidental expenses have been apportioned and distributed to the benefiting parcels in accordance with the special benefits received from the proposed work.
6. Notice is hereby given of a public hearing on the 26th day of June, 2024 at 6:00 P.M.
7. At that time, the legislative body will consider and finally determine whether to levy the proposed annual assessment, and to hear all protests relating to said proposed proceedings, or the estimate of the cost and expenses of the proposed maintenance, or the proposed annual assessment; and any and all persons interested may file a written protest at clerkoffice@cosb.org before 12:00 p.m. of the hearing day or, having

filed such a protest, may file a written withdrawal of that protest at clerkoffice@cosb.org prior to 12:00 p.m. of such hearing day. Any such written protest must state all grounds for objection. A written protest by a property owner must contain a description sufficient to identify the property owned by such person, e.g. assessor's parcel number.

Any interested person may mail a protest to the following address:

CITY CLERK
CITY OF SOLANA BEACH
635 S. HIGHWAY 101
SOLANA BEACH, CA 92075
clerkoffice@cosb.org

To be considered by the legislative body, all protests must be received by 12:00 p.m. the public hearing date. A postmark prior to such date and time will not be sufficient.

8. That the City Clerk is hereby authorized and directed to give notice as required by law by causing a copy of the Resolution to be published in the newspaper of general circulation within said City; and publication to be completed not less than ten (10) days prior to the date set for the public hearing.

PASSED AND ADOPTED this 22nd day of May 2024, at a Regular Meeting of the City Council of the City of Solana Beach, California by the following vote:

AYES: Councilmembers –
NOES: Councilmembers –
ABSTAIN Councilmembers –
ABSENT: Councilmembers –

LESA HEEBNER, Mayor

APPROVED AS TO FORM:

ATTEST:

JOHANNA N. CANLAS, City Attorney

ANGELA IVEY, City Clerk



City Of Solana Beach

Coastal Rail Trail Maintenance District
Engineer's Report
Fiscal Year 2024/2025

Date May 8, 2024

KOPPEL & GRUBER
PUBLIC FINANCE

334 Via Vera Cruz, Suite 256

San Marcos, California 92078

760-510-0290

info@kgpl.net

TABLE OF CONTENTS

SECTION I.	OVERVIEW	1
SECTION II.	PLANS AND SPECIFICATION.....	3
SECTION III.	PROPOSED FISCAL YEAR 2024/2025 BUDGET	5
A.	ESTIMATED FISCAL YEAR 2024/2025 BUDGET	5
B.	DESCRIPTION OF BUDGET ITEMS.....	7
SECTION IV.	METHOD OF APPORTIONMENT	8
A.	GENERAL	8
B.	GENERAL BENEFIT ANALYSIS	8
C.	SPECIAL BENEFIT ANALYSIS	9
D.	ASSESSMENT METHODOLOGY	10
E.	RATES	12
F.	ASSESSMENT RANGE FORMULA.....	13
SECTION V.	ASSESSMENT ROLL.....	14
SECTION VI.	ASSESEMENT DIAGRAM.....	15

SECTION I. OVERVIEW

A. INTRODUCTION AND BACKGROUND

The Coastal Rail Trail (the “CRT”) is a project sponsored by the cities of Oceanside, Carlsbad, Encinitas, Solana Beach and San Diego for a multi-use pathway (bicycle facilities and pedestrian) that will ultimately extend from the San Luis Rey River in Oceanside to the Santa Fe Depot in San Diego. Each of the sponsoring cities has agreed to construct and maintain the portion of the trail that is located within their jurisdiction. The City of Solana Beach (the “City”) began construction on their portion of the CRT (“City CRT”) in August 2003 by obtaining outside grants and the City CRT was substantially completed in November of 2004.

The City CRT consists of a Class I bicycle trail that is approximately 1.7 miles long. The Solana Beach portion of the CRT starts at the south City boundary at Via de la Valle and extends north to Ocean Street near the north City boundary.

The City of Solana Beach Coastal Rail Trail Maintenance District (“District”) was formed in January 2006 in order to provide funding for the maintenance of certain public improvements including but not limited to the operation, maintenance and servicing of landscaping and public lighting improvements along the City CRT. This report constitutes the Fiscal Year 2024/2025 Engineer’s Report for the District.

The City Council pursuant to the provisions of the *Landscaping and Lighting Act of 1972, Part 2 of Division 15 of the Streets and Highways Code of California, beginning with Section 22500* (“Act”) and in compliance with the substantive and procedural requirements of the *California State Constitution Article XIIC and XIID* (“Proposition 218”) and the *Proposition 218 Omnibus Implementation Act (Government Code Section 53750 and following)* (the “Implementation Act”) desires to levy and collect annual assessments against lots and parcels within the District beginning in the fiscal year commencing July 1, 2024 and ending June 30, 2025 to pay for the operation, maintenance and servicing of landscaping and public lighting improvements along the City CRT. The proposed assessments are based on the City’s estimate of the costs for Fiscal Year 2024/2025 to maintain the City CRT improvements that provide a special benefit to properties assessed within the District. The assessment rates set for Fiscal Year 2024/2025 as set forth in this Engineer’s Report, do not exceed the maximum rates established at the time the District was formed, therefore, the City and the District are not required to go through a property owner ballot procedure in order to establish the 2024/2025 assessment rates.

B. CONTENTS OF ENGINEER’S REPORT

This Report describes the District boundaries and the proposed improvements to be assessed to the property owners located within the District. The Report is made up of the following sections.

SECTION I. OVERVIEW – Provides a general introduction into the Report and provides background on the District and the assessment.

SECTION II. PLANS AND SPECIFICATIONS – Contains a general description of the improvements that are maintained and serviced by the District.

SECTION III. PROPOSED FISCAL YEAR 2024/2025 BUDGET – Identifies the cost of the maintenance and services to be provided by the District including incidental costs and expenses.

SECTION IV. METHOD OF APPORTIONMENT – Describes the basis in which costs have been apportioned to lots or parcels within the District, in proportion to the special benefit received by each lot or parcel.

SECTION V. ASSESSMENT ROLL – The assessment roll identifies the maximum assessment to be levied to each lot or parcel within the District.

SECTION VI. ASSESSMENT DIAGRAM – Displays a diagram of the District showing the boundaries of the District.

For this Report, each lot or parcel to be assessed, refers to an individual property assigned its own Assessment Parcel Number (“APN”) by the San Diego County (“County”) Assessor’s Office as shown on the last equalized roll of the assessor.

Following the conclusion of the Public Hearing, the City Council will confirm the Report as submitted or amended and may order the collection of assessments for Fiscal Year 2024/2025.

SECTION II. PLANS AND SPECIFICATION

A. GENERAL DESCRIPTION OF THE DISTRICT

The boundaries of the District are defined as being contiguous with the boundaries of the City of Solana Beach. Solana Beach is located approximately thirty miles north of the City of San Diego in the north coastal area of the County. The City is bordered by the Pacific Ocean to the west, the City of Encinitas to the north, the City of Del Mar to the south and the County of San Diego to the east.

The properties within the District include single-family residential, multi-family residential, timeshare, commercial, and industrial parcels. Each parcel has been categorized into three zones based upon their general proximity to the City CRT. Please refer to Section IV D of the Report for a further explanation on the zones included within the District.

B. DESCRIPTION OF SERVICES AND IMPROVEMENTS TO BE MAINTAINED

The District provides a funding mechanism for the ongoing maintenance, operation and servicing of landscaping and public lighting improvements that were installed as part of the construction of the City CRT. These improvements may include, but are not limited to, all materials, equipment, utilities, labor, and appurtenant facilities related to those improvements.

The improvements constructed as part of the project that are to be maintained and serviced by the District relate to landscaping and public lighting improvements, and are generally described as follows:

- Concrete and decomposed granite trails including landscaping, irrigation, drainage, grading, lighting, and hardscape features.
- Concrete paths, trees, plantings, lighting, irrigation, conduit, infrastructure, earthwork, trash receptacles, fencing, node structures (bus shelters, art amenities, garden nodes), drinking fountains, signage, and observation deck.
- Open space and irrigated and planted slopes located along the Trail.
- Public lighting facilities within and adjacent to the City CRT.

Maintenance services will be provided by City personnel and/or private contractors. The proposed improvements to be maintained and services are generally described as follows:

LANDSCAPING AND APPURTENANT IMPROVEMENTS

The landscaping improvements and services to be maintained by the District include but are not limited to landscaping, planting, ground cover, shrubbery, turf, trees, irrigation and drainage systems, hardscape, fixtures, sidewalks, fencing and other appurtenant items located along and adjacent to the City CRT.

PUBLIC LIGHTING AND APPURTENANT IMPROVEMENTS

The public lighting improvements to be maintained and serviced include but are not limited to the following, which provide public lighting directly or indirectly to the City CRT or to other public areas associated with or necessary for use of the trail:

- Maintenance, repair and replacement of public light poles and fixtures, including changing light bulbs, painting, photoelectric cell repair or replacement, and repairing damage caused by automobile accidents, vandalism, time, and weather.
- Electrical conduit repair and replacement due to damage by vandalism, time and weather.
- Service-call maintenance, repair and replacement including painting, replacing worn out electrical components and repairing damage due to accidents, vandalism, and weather.
- Payment of the electrical bill for the existing street lighting system.
- Responding to constituent and business inquiries and complaints regarding the public lighting.

Maintenance means the furnishing of services and materials for the ordinary and usual maintenance, operation and servicing of landscaping and public lighting improvements facilities and appurtenant facilities. This includes repair, removal or replacement of all or part of any of the landscaping and street lighting improvements, or appurtenant facilities; providing for the life, growth, health and beauty of landscaping improvements and for the operation of the lighting improvements.

Servicing means the furnishing of all labor, materials, equipment and utilities necessary to maintain the landscaping improvements and to maintain and operate the public lighting improvements or appurtenant facilities in order to provide adequate illumination.

SECTION III. PROPOSED FISCAL YEAR BUDGET

A. ESTIMATED FISCAL YEAR 2024/2025 BUDGET

A summary of the proposed District Fiscal Year 2024/2025 budget is summarized, by category, in Table 1 shown on the following page:

Table 1
CITY OF SOLANA BEACH
COASTAL RAIL TRAIL MAINTENANCE DISTRICT
2024/2025 BUDGET

	TOTAL BUDGET	GENERAL BENEFIT PORTION ^{1&2}	PROPOSED FY 2024/2025 ASSESSMENT
OPERATING AND MAINTENANCE COSTS			
Operating and Maintenance			
Landscape, Irrigation & Hardscape Maintenance Thru an Outside Contract (Includes Tree Trimming)	\$68,500	\$3,500	\$65,000
Utilities (Water)	\$21,000	\$0	\$21,000
Utilities (Electricity)	\$29,500	\$29,500	\$0
Trail Maintenance (DG & Concrete Paths)	\$1,400	\$0	\$1,400
Graffiti Abatement	\$200	\$0	\$200
Advertising	\$700	\$0	\$700
Total Operating and Maintenance Costs	\$121,300	\$33,000	\$88,300
CAPITAL REPLACEMENT AND RESERVES			
Capital Replacement			
Landscape & Irrigation Replacement	\$3,600	\$100	\$3,500
Pedestrian/Bicycle Path Replacement	\$2,500	\$0	\$2,500
Hardscape Features Replacement (water fountain, art work, bus shelter)	\$2,600	\$100	\$2,500
Reserves			
Fiscal Year 2024/2025 Reserve Collection	\$0	\$0	\$0
Total Capital Replacement and Reserves	\$8,700	\$200	\$8,500
ADMINISTRATION COSTS			
District Administration Costs			
County SB 2557 Costs			\$598
County Electronic Data Processing Costs			\$602
City Administration/Consultant Costs			\$8,231
Total Administration Costs			\$9,431
AMOUNT TO LEVY			
TOTAL BUDGET			\$106,231
LESS OPERATING RESERVES USED IN FY²			(\$22,054)
TOTAL ASSESSMENT AMOUNT			\$84,177
Total Parcels in the District			13,105
Total Parcels Levied			5,658
Total Equivalent Benefit Units			10,069.13
Proposed Levy Per Equivalent Benefit Unit			\$8.36
Inflation Percentage Applied to Proposed Levy Per EBU			2.00%
OPERATING RESERVES			
Beginning Balance as of 7/1/24			\$45,984
FY 2024/2025 Collection			\$84,177
Expenditures			(\$106,231)
Projected Ending Balance as of 6/30/25 ³			\$23,930
Maximum Recommended Cash Flow Reserve Amount			\$42,089

1. While the cost of the electricity is not 100% general benefit, the City is paying for the entire cost through other available funds and none of the cost is being allocated to the parcels located within the District.
2. The CRT landscaping cost is greater than the available funding from the District so other available funding is being utilized to cover the difference.
3. The City is developing a plan on how to utilize the operating reserves on the CRT in the future.

B. DESCRIPTION OF BUDGET ITEMS

The following is a brief description of the major budget categories that includes the detailed costs of maintenance and services for the District included in the table above.

OPERATING AND MAINTENANCE COSTS – This includes the costs of maintaining and servicing the landscaping and lighting improvements. This may include, but is not limited to, the costs for labor, utilities, equipment, supplies, repairs, replacements and upgrades that are required to properly maintain the items that provide a direct benefit to properties located within the District.

CAPITAL REPLACEMENT AND RESERVES – These items provide a funding source to pay for items that wear out over time, other unanticipated items not directly budgeted for and for the replacement of the landscaping, pathways and hardscape features located along and adjacent to the City CRT.

ADMINISTRATION COSTS – This includes the indirect costs not included above that are necessary to pay for administrative costs related to the District, including the levy and submittal of the assessments to the County to be placed on the Fiscal Year 2024/2025 County equalized tax roll, responding to property owner inquiries relating to the assessments and services, and any other related administrative costs.

SECTION IV. METHOD OF APPORTIONMENT

A. GENERAL

The 1972 Act permits the establishment of assessment districts by agencies for the purpose of providing certain public improvements, which include the construction, maintenance, and servicing of landscaping and public lights and appurtenant facilities.

Streets and Highways Code Section 22573 requires that maintenance assessments be levied according to benefit rather than the assessed value.

“The net amount to be assessed upon lands within an assessment district may be apportioned by any formula or method which fairly distributes the net amount among all assessable lots or parcels in proportion to the estimated benefits to be received by each such lot or parcel from the improvements.”

In addition, Article XIID and the Implementation Act require that a parcel’s assessment may not exceed the reasonable cost for the proportional special benefit conferred to that parcel. A special benefit is a particular and distinct benefit over and above general benefits conferred on property located within the assessment district. Article XIID and the Implementation Act further provides that only special benefits are assessable and the City must separate the general benefits from the special benefits. They also require that publicly owned properties which specifically benefit from the improvements be assessed.

B. GENERAL BENEFIT ANALYSIS

The improvements described in Section II B of this Report are for the special benefit, enhancement and use of properties within the District. However, the City CRT was constructed as a portion of a much larger regional trail that eventually will extend from the City of Oceanside to the north to the City of San Diego to the south. Residents and property owners located in each of the cities along the trail will receive a special benefit from the construction and maintenance of the trail within their city. Residents from each of these cities will have an opportunity to use the entire trail upon completion including the portion in Solana Beach which creates a general benefit.

Additionally, included among the different property types in the City are timeshare units. Though individuals may purchase and “own” their timeshare unit, their ownership rights are limited and temporary (typically one week per year.) Owners of timeshare units have an opportunity to use the CRT while vacationing in the City. Due to the limited ownership time-frame of timeshare owners, their special benefit is limited and thus considered as part of the general benefit similar to the general benefit to the public at large.

The general benefit portion of the assessment has been determined by looking at each participating city’s trail length as a factor of the entire trail. The City of Solana Beach’s portion of the CRT is 1.7 miles compared to the entire proposed trail length of 44.0 miles. Comparing the length of the City CRT to the total length of the CRT results in a general benefit of 3.86%. Engineering also determined that timeshares add an additional 2.0%

general benefit impact. For rounding purposes after adding the two components (3.86% + 2.0%) the general benefit is considered to be 6.0% overall to the public at large. The budget has been allocated to parcels based on their special benefit share. In addition, the City is paying 100% of the electricity costs, totaling \$29,500, for the District through funds available from other sources resulting in over 30% of the costs paid directly by the City.

C. SPECIAL BENEFIT ANALYSIS

Each of the proposed improvements and the associated costs and assessments within the District has been reviewed, identified and allocated based on special benefit pursuant to the provisions of Article XIID, the Implementation Act, and the Streets and Highways Code Section 22573.

Proper maintenance and operation of the City CRT landscaping, hardscape, open space and public lighting provides special benefit to adjacent properties by providing community character, security, safety and vitality. Additionally, one of the purposes of the trail is to facilitate alternative transportation opportunities in order to reduce air pollution and vehicular traffic congestion which provide special benefit to the properties within the District.

TRAIL AND LANDSCAPING SPECIAL BENEFIT

Landscaping and appurtenant facilities, if well maintained, provide beautification, shade and enhancement of the desirability of the surroundings, and therefore increase property values. Specifically, they provide a sense of ownership and a common theme in the community providing aesthetic appeal, recreational and health opportunities and increased desirability of properties.

PUBLIC LIGHTING SPECIAL BENEFIT

The operation, maintenance and servicing of public lighting along and adjacent to the City CRT provide safety and security to properties along City CRT specifically as follows:

- Improved security, deterrence of crime and aid to police and fire protection.
- Reduced vandalism and damage to the improvements and property.
- Increased business activity to the coastal community during nighttime hours.

D. ASSESSMENT METHODOLOGY

To establish the special benefit to the individual lots or parcels within the District, an Equivalent Benefit Unit system based on land use is used along with a Zone Factor based on geographic proximity to the City CRT.

EQUIVALENT BENEFIT UNITS

Each parcel of land is assigned an Equivalent Benefit Unit in proportion to the estimated special benefit the parcel receives relative to other parcels within the District. The single family detached (“SFD”) residential property has been selected as the basic unit for calculating assessments; therefore, a SFD residential parcel equals one Equivalent Benefit Unit (“EBU”).

The EBU method of apportioning benefit is typically seen as the most appropriate and equitable assessment methodology for districts formed under the 1972 Act, as the benefit to each parcel from the improvements are apportioned as a function of land use type, size and development. A methodology has been developed to relate all other land uses to the SFD residential as described below.

EBU APPLICATION BY LAND USE:

SINGLE-FAMILY RESIDENTIAL — This land use is defined as a fully subdivided residential parcel in which a tract map has been approved and recorded. This land use is assessed 1.0 EBU per lot or parcel. This is the base value that all other land use types are compared and weighted against (i.e. Equivalent Benefit Unit or EBU).

RESIDENTIAL CONDOMINIUM — This land use is defined as a fully subdivided residential parcel that has more than one residential unit developed on the property with individual unit ownership. This land use is assessed 1.0 EBU per dwelling unit.

MULTI-FAMILY RESIDENTIAL — This land use is defined as a fully subdivided residential parcel that has more than one residential unit developed on the property not available for individual unit ownership. This land use is assessed 0.75 EBU per dwelling unit.

PLANNED-RESIDENTIAL DEVELOPMENT — This land use is defined as any property not fully subdivided with a specific number of proposed residential lots or dwelling units to be developed on the parcel. This land use type is assessed at 1.0 EBU per planned (proposed) residential lot or dwelling unit.

COMMERCIAL/INDUSTRIAL — This land use is defined as property developed for either commercial or industrial use. This land use type is assessed at 1.0 EBU per parcel.

VACANT SINGLE-FAMILY RESIDENTIAL — This land use is defined as property currently zoned for single-family detached residential development, but a tentative or final tract map has not been submitted and/or approved. This land use is assessed at 1.0 EBU per parcel.

VACANT MULTI-FAMILY RESIDENTIAL — This land use is defined as property currently zoned for multi-family residential development, but a tentative or final tract map has not been submitted and/or approved. This land use is assessed at 0.75 EBU per parcel.

VACANT COMMERCIAL/INDUSTRIAL — This land use is defined as property currently zoned for either commercial or industrial use. This land use is assessed at 1.0 EBU per parcel.

EXEMPT PARCELS — This land use identifies properties that are not assessed and are assigned 0.0 EBU. This land use classification may include, but is not limited, to lots or parcels identified as public streets and other roadways (typically not assigned an APN by the County); dedicated public easements, open space areas and right-of-ways including greenbelts and parkways; utility right-of-ways; common areas, sliver parcels and bifurcated lots or any other property that can not be developed; park properties and other publicly owned properties that are part of the District improvements or that have little or no improvement value. These types of parcels are considered to receive little or no benefit from the improvements and are therefore exempted from assessment.

PUBLIC OWNED PARCELS — This land use identifies properties that are not assessed and are assigned 0.0 EBU. This land use classification includes other typically non-assessed parcels that are not considered exempt parcels and may include, but is not limited, to lots or parcels identified as schools, government owned buildings, fire and police stations, and administration offices. These types of properties are considered to receive little special benefit from the improvements and any benefit that they may receive is considered to be part of the City’s general benefit contribution to the District.

ZONE FACTOR

The District was divided into three zones based on the proximity of parcels in location to the City CRT. Properties located the closest to the trail will receive a greater special benefit as compared to those parcels the farthest away. In order to calculate this into the assessment a factor is applied to each parcel according to the following Zone location.

ZONE 1 PROPERTIES – This Zone is defined as properties located adjacent to or within a few blocks of the City CRT improvements. This includes all properties that are generally located east of Acacia and Sierra Avenue and west of Rios Avenue. Parcels located in this zone use the EBU amounts derived above based on land use and then multiplied by a proximity factor of three (3).

ZONE 2 PROPERTIES – This Zone is defined as properties located close to the improvements but not adjacent to the City CRT or properties defined as Zone 1 Properties. This includes all properties that are generally located west of Acacia Avenue and also those properties located east of Rios Avenue and west of Interstate-5. Parcels located in this zone use the EBU amounts derived above based on land use and then multiplied by a proximity factor of two (2).

ZONE 3 PROPERTIES – This Zone is defined as properties located the furthest away from the City CRT improvements. This includes all properties that are located east of Interstate-5. Parcels located in this zone use the EBU amounts derived above based on land use and then multiplied by a proximity factor of 0.5.

The following table summarizes the EBU and Zone Factors based on land use.

Table 2

**CITY OF SOLANA BEACH
COASTAL RAIL TRAIL MAINTENANCE DISTRICT
EQUIVALENT BENEFIT UNITS AND ZONE FACTOR BY LAND USE**

Land Use Description	Equivalent Benefit Units (EBUs)	Per	Zone 1 Multiplier	Zone 2 Multiplier	Zone 3 Multiplier	No. of EBUs for Property in Zone 1	No. of EBUs for Property in Zone 2	No. of EBUs for Property in Zone 3
Single Family Residential	1.00	Lot or Parcel	3.00	2.00	0.50	3.00	2.00	0.50
Residential Condominium	1.00	Dwelling Unit	3.00	2.00	0.50	3.00	2.00	0.50
Multi-Family Residential	0.75	Dwelling Unit	3.00	2.00	0.50	2.25	1.50	0.38
		Lot or Dwelling						
Planned Residential Development	1.00	Unit	3.00	2.00	0.50	3.00	2.00	0.50
Commercial/Industrial	1.00	Parcel	3.00	2.00	0.50	3.00	2.00	0.50
Vacant Single Family Residential	1.00	Parcel	3.00	2.00	0.50	3.00	2.00	0.50
Vacant Multi-Family Residential	0.75	Parcel	3.00	2.00	0.50	2.25	1.50	0.38
Vacant Commercial/Industrial	1.00	Parcel	3.00	2.00	0.50	3.00	2.00	0.50
		1 week of						
Timeshare Units	0.00	ownership	3.00	2.00	0.50	0.00	0.00	0.00
Exempt Parcels	0.00	Parcel	3.00	2.00	0.50	0.00	0.00	0.00
Public Owned Parcels	0.00	Parcel	3.00	2.00	0.50	0.00	0.00	0.00

In order to determine the maximum annual assessment rate for each type of land use described above, the following formula is applied:

Applicable EBU * Applicable Zone Factor*Maximum Assessment Rate per 1.0 EBU=Assessment Rate per Unit/Parcel.

E. RATES

Table 3 below shows the maximum assessments rates proposed to be levied in Fiscal Year 2024/2025 by land use. Because the San Diego Consumer Price Index for All Urban Consumers (“CPI-U”) was over 2.00% for 2023 (5.51%), the maximum assessments were increased by 2.00% as allowed for in the assessment range formula discussed below.

Table 3

**CITY OF SOLANA BEACH
COASTAL RAIL TRAIL MAINTENANCE DISTRICT
EQUIVELANT BENEFIT UNITS AND ZONE FACTOR BY LAND USE**

Land Use Description	Per	Base Rate for Zone 1	Base Rate for Zone 2	Base Rate for Zone 3
Single Family Residential	Lot or Parcel	\$25.08	\$16.72	\$4.18
Residential Condominium	Dwelling Unit	\$25.08	\$16.72	\$4.18
Multi-Family Residential	Dwelling Unit	\$18.82	\$12.54	\$3.14
	Lot or Dwelling			
Planned Residential Development	Unit	\$25.08	\$16.72	\$4.18
Commercial/Industrial	Parcel	\$25.08	\$16.72	\$4.18
Vacant Single Family Residential	Parcel	\$25.08	\$16.72	\$4.18
Vacant Multi-Family Residential	Parcel	\$18.82	\$12.54	\$3.14
Vacant Commercial/Industrial	Parcel	\$25.08	\$16.72	\$4.18
	1 week of			
Timeshare Units	ownership	\$0.00	\$0.00	\$0.00
Exempt Parcels	Parcel	\$0.00	\$0.00	\$0.00
Public Owned Parcels	Parcel	\$0.00	\$0.00	\$0.00

F. ASSESSMENT RANGE FORMULA

The purpose of establishing an Assessment Range Formula is to provide for reasonable inflationary increases to the annual assessments without requiring the District to go through an expensive balloting process required by law in order to get a small increase. On July 1, 2007 and each year thereafter, the Maximum Assessment Rate shall be increased by the lesser of Local CPI-U in the San Diego County area or 2.0%. The CPI-U used shall be as determined annually by the Bureau of Labor Statistics beginning with the CPI-U rate increase for 2006.

Beginning in the Fiscal Year 2007/2008 the Maximum Assessment may be increased using the lesser of the increase in the CPI-U from first year levy (the Assessment Range Formula) or 2.0%. This Assessment Rate Formula would be applied every fiscal year thereafter and a new Maximum Assessment will be established to include the allowable increase.

The Maximum Assessment adjusted annually by this formula is not considered an increased assessment. Although the Maximum Assessment will increase each year, the actual assessment will only reflect the necessary budgeted amounts and may remain unchanged. Increases in the budget or an increase in the rate in one year from the prior year will not require a new 218 balloting unless the rate is greater than the Maximum Assessment adjusted to reflect an increase in the CPI-U.

SECTION V. ASSESSMENT ROLL

Parcel identification, for each lot or parcel within the District shall be the parcel as shown on the County Assessor's map for the year in which this Report is prepared.

A listing of parcels assessed within the District, along with the proposed assessment amounts, has been submitted to the City Clerk, under a separate cover, and by reference is made part of this Report. Said listing of parcels to be assessed shall be submitted to the County Auditor/Controller and included on the property tax roll for each parcel in Fiscal Year 2024/2025. If any parcel submitted for collection is identified by the County Auditor/Controller to be an invalid parcel number for the current fiscal year, a corrected parcel number and/or new parcel numbers will be identified and resubmitted to the County Auditor/Controller. The assessment amount to be levied and collected for the resubmitted parcel or parcels shall be based on the method of apportionment and assessment rate approved in this Report. Therefore, if a single parcel has changed to multiple parcels, the assessment amount applied to each of the new parcels shall be recalculated and applied according to the approved method of apportionment and assessment rate rather than a proportionate share of the original assessment.

SECTION VI. ASSESSMENT DIAGRAM

The parcels within the District consist of all lots, parcels and subdivisions of land located in the City. A reduced copy of the boundary map of the area is attached.

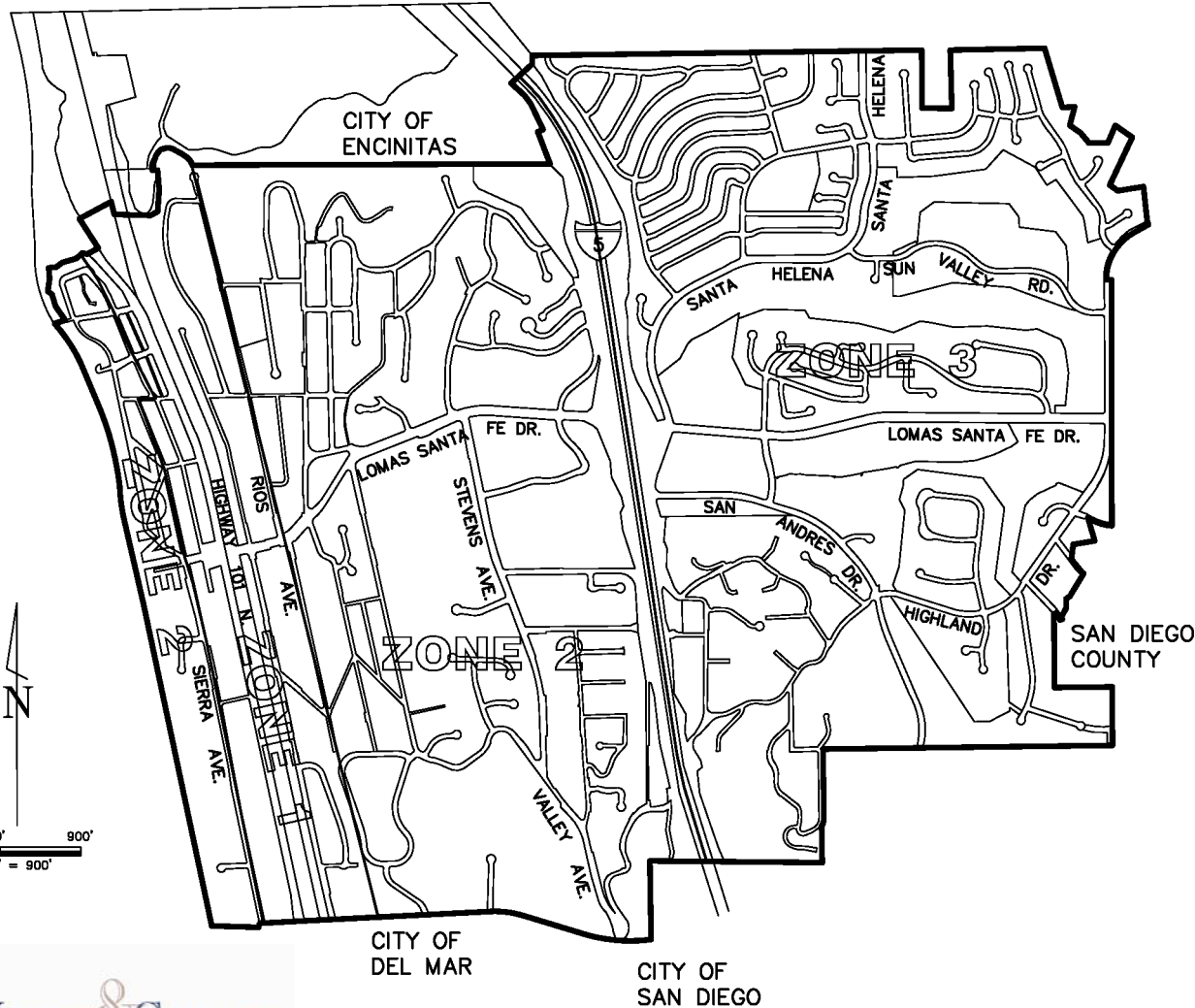

FILED IN THE OFFICE OF THE CITY CLERK OF THE CITY OF SOLANA BEACH THIS _____ DAY OF _____, 2005.

I HEREBY CERTIFY THAT THE WITHIN MAP SHOWING PROPOSED BOUNDARIES OF THE COASTAL RAIL TRAIL MAINTENANCE DISTRICT, CITY OF SOLANA BEACH, COUNTY OF SAN DIEGO, STATE OF CALIFORNIA, WAS APPROVED BY THE CITY COUNCIL OF THE CITY OF SOLANA BEACH AT A REGULAR MEETING THEREOF, HELD ON THE _____ DAY OF _____, 2005, BY ITS RESOLUTION NO. _____

CITY CLERK
CITY OF SOLANA BEACH

NOTE: FOR PARTICULARS OF THE LINES AND DIMENSIONS OF ASSESSOR'S PARCELS, REFERENCE IS MADE TO THE MAPS OF THE SAN DIEGO COUNTY ASSESSOR OF SAN DIEGO COUNTY RECORDS, WHICH MAPS SHALL GOVERN FOR ALL DETAILS RELATING THERETO.



334 Via Vera Cruz
Suite 266
San Marcos, California 92078
Phone (760) 510-0280 Fax (760) 510-0288

PROPOSED BOUNDARY MAP OF COASTAL RAIL TRAIL MAINTENANCE DISTRICT

CITY OF SOLANA BEACH
COUNTY OF SAN DIEGO
STATE OF CALIFORNIA

CITY OF SOLANA BEACH

**CITY OF SOLANA BEACH
COASTAL RAIL TRAIL MAINTENANCE DISTRICT**

**Engineer's Report
Fiscal Year 2024/2025**

The undersigned respectfully submits the enclosed Report as directed by City Council.

Report Submitted By:



By: _____
Scott Koppel
Koppel & Gruber Public Finance

By: _____
Mohammad Sammak



STAFF REPORT CITY OF SOLANA BEACH

TO: Honorable Mayor and City Councilmembers
FROM: Alyssa Muto, City Manager
MEETING DATE: May 22, 2024
ORIGINATING DEPT: Engineering Department
SUBJECT: **City Council Consideration of Resolution 2024-049 and 2023-050 for the Engineer's Report, the Annual Levy and Collection of Assessments for the Solana Beach Lighting District for FY 2024/25**

BACKGROUND:

In 1987, the City Council adopted a resolution forming the Solana Beach Lighting District (District) under the provisions of the Landscape and Lighting Act of 1972, Division 15, Part 2, of the California Streets and Highways Code (1972 Act). The District was formed for the purpose of levying and collecting funds for the installation, operation, and maintenance of streetlight facilities within the City.

The 1972 Act requires the City Council to adopt a resolution annually directing the preparation and filing of an Annual Report and a Resolution of Intention to renew the District. The resolutions declare the City Council's intention to levy and collect assessments and set the date of the public hearing at which the assessments will be levied. The law requires the assessment information to be submitted to the County by August 10th each year. In Fiscal Year (FY) 2008/09, fees for the District were suspended. During the period of FY 2009/10 through FY 2023/24, fees were collected but the rate was not increased. Staff is proposing no increase in fees for FY 2024/25.

Utilizing a portion of the reserve funds in the district, all City-owned streetlights were retrofitted to LED fixtures in 2012. The LED lights are much more energy efficient than the old lights. The streetlights in Solana Beach are not metered and the City pays a set rate for each light. SDG&E has reduced the rates for the LED retrofitted lights and the savings are reflected in the budget. The retrofitted LED lights use approximately 50% less energy than the standard streetlights that were previously used.

CITY COUNCIL ACTION:

AGENDA ITEM # A.5.

This item is before the City Council for the consideration of Resolution 2024-049 (Attachment 1) approving the Solana Beach Lighting Maintenance District Engineer's Report for Fiscal Year 2024/25 and Resolution 2024-050 (Attachment 2) setting a time and place for a Public Hearing.

DISCUSSION:

The proposed Solana Beach Lighting Maintenance District Engineer's Report for FY 2024/25 is included as Attachment 3. The recommended assessment methodology is a Spread Methodology as outlined in the Calculation of Assessment Fees, page 7 of Attachment 3. The total amount to be assessed for streetlights for FY 2024/25 is \$75,270. The Derivation of Streetlighting Benefit Units table in Exhibit 2 (page 9 and 10) is found to be consistent with the current SANDAG Traffic Generation Manual and is appropriate for the associated land uses. The improvements include those designated in the district boundaries and shown in the City's Streetlight Master Plan.

The District is the successor agency to portions of San Diego County Lighting Maintenance District Nos. 1 and 3 (LMD1 and LMD3). Ballots issued in 1982 and 1984 to levy assessments for LMD1 and LMD3 were approved to have a maximum charge of \$25.00 per benefit unit. This maximum benefit unit charge will not apply to Zone B of the District as it was formed since Solana Beach was incorporated.

The annual assessment fees are collected based on property locations in the City, identified as Zone A or Zone B, as shown on the Streetlight Zone Map in Exhibit 1 (page 8) of Attachment 3. The annual assessment fees for this year are \$8.80 per benefit unit for Zone A and \$1.62 for Zone B. These fees are the same assessment fees as last year. In order to levy and collect an assessment in the District, it is necessary to notify the property owners of the City. The City will publish one notice in a newspaper of local circulation indicating the public hearing to be held on June 26, 2024.

CEQA COMPLIANCE STATEMENT:

Not a project as defined by CEQA.

FISCAL IMPACT:

The District has been financed by a benefit charge and by using the District's share of one percent ad valorem property tax revenues since FY 1989/90. The amount to be generated from the benefit assessment is proposed to be \$8.80 per benefit unit in Zone A and \$1.62 in Zone B, which are unchanged from last year, for a total assessment of \$75,270 in FY 2024/25. The amount to be assessed this year is slightly down from the assessed amount from last year. This is due to the property at the Solana Highlands Apartments along Nardo Avenue being classified as vacant land. Once construction of that project is completed, the property will be reclassified and the number of EDUs will increase.

WORK PLAN:

Renewal of the District is consistent with the Fiscal Sustainability section of the City's Work Plan.

OPTIONS:

- Accept the Engineer's Report for proceeding with the annual levy of assessments and set time and date for a public hearing on June 26, 2024.
- Suspend assessment for FY 2024/25.
- Do not renew the Lighting District and provide direction to Staff.

DEPARTMENT RECOMMENDATION:

Staff recommends that the City Council:

1. Adopt Resolution 2024-049 approving the Solana Beach Lighting Maintenance District Engineer's Report for Fiscal Year 2024/25 for proceedings of the annual levy of assessments within a special maintenance district.
2. Adopt Resolution 2024-050 declaring intention to provide for an annual levy and collection of assessment in a special maintenance district and setting a time and date for a public hearing; and scheduling the public hearing for June 26, 2024.

CITY MANAGER'S RECOMMENDATION:

Approve Department Recommendation.



Alyssa Muto, City Manager

Attachments:

1. Resolution 2024-049, Approving Engineer's Report
2. Resolution 2024-050, Setting Public Hearing
3. Lighting Maintenance District Engineer's Report for FY 2024/25

RESOLUTION 2024-049

A RESOLUTION OF THE CITY COUNCIL OF THE CITY OF SOLANA BEACH, CALIFORNIA, APPROVING THE SOLANA BEACH LIGHTING MAINTENANCE DISTRICT ENGINEER'S REPORT FOR FISCAL YEAR 2024/25 FOR PROCEEDINGS FOR THE ANNUAL LEVY OF ASSESSMENTS WITHIN A SPECIAL LIGHTING DISTRICT

WHEREAS, the City Council of the City of Solana Beach, California, pursuant to the terms of the "Landscaping and Lighting Act of 1972", being Division 15, Part 2 of the Streets and Highways Code of the State of California, did, by separate Resolution, initiate proceedings and order the preparation of the Engineer's Report (hereinafter referred to as Report) for the annual levy of assessments within a special Lighting District, said special Lighting District known and designated as Solana Beach Lighting District (hereinafter referred to as Lighting District); and

WHEREAS, the Report, as required by said Division 15 of the Streets and Highways Code and as previously directed by Resolution, was presented to the City Council; and

WHEREAS, the City Council examined and reviewed the Report as presented and is satisfied with each and all the items and documents as set forth therein, and is satisfied that the assessments, on a preliminary basis, are spread in accordance with the special benefits received from the improvements to be maintained, as set forth in said Report.

NOW, THEREFORE, the City Council of the City of Solana Beach, California does resolve as follows:

1. That the above recitals are all true and correct
2. That the Solana Beach Lighting Maintenance District Engineer's Report for Fiscal Year 2024/25, as presented, consists of the following:
 - a. Plans and specifications describing the general nature, location and extent of the improvements to be maintained as described in the City's Street Light Master Plan. No other substantial changes in existing improvements or zones are proposed for the next fiscal year; all improvements to be maintained are in existing public streets, or sidewalks, or public leaseholds, of the City;
 - b. Estimate of cost, including the amount of the annual installment for the forthcoming fiscal year;
 - c. Diagram of the Lighting District;

- d. Assessment of the estimated cost, including the amount of individual annual installments for the next fiscal year. No assessments on any existing parcels within the Lighting District are to be increased from those as levied in Fiscal Year 2023/24.
- 3. That the Report, as presented, is hereby approved on a preliminary basis, and is ordered to be filed in the Office of the City Clerk as a permanent record and to remain open to public inspection.
- 4. That the City Clerk shall certify the passage and adoption of this Resolution, and the minutes of this meeting shall so reflect the presentation of the Solana Beach Lighting Maintenance District Engineer's Report for Fiscal Year 2024/25.

PASSED AND ADOPTED this 22nd day of May, 2024, at a Regular Meeting of the City Council of the City of Solana Beach, by the following vote:

AYES: Councilmembers –
NOES: Councilmembers –
ABSENT: Councilmembers –
ABSTAIN: Councilmembers –

LESA HEEBNER, Mayor

APPROVED AS TO FORM:

ATTEST:

JOHANNA N. CANLAS, City Attorney

ANGELA IVEY, City Clerk

RESOLUTION 2024-050

A RESOLUTION OF THE CITY COUNCIL OF THE CITY OF SOLANA BEACH, CALIFORNIA, DECLARING ITS INTENTION TO PROVIDE FOR AN ANNUAL LEVY AND COLLECTION OF ASSESSMENTS IN A SPECIAL LIGHTING DISTRICT, AND SETTING A TIME AND PLACE FOR PUBLIC HEARING THEREON

WHEREAS, the City Council of the City of Solana Beach, California, has previously formed a special Lighting District pursuant to the terms of the "Landscaping and Lighting Act of 1972", being Division 15, Part 2 of the Streets and Highways Code of the State of California, said special Lighting District known and designated as Solana Beach Lighting District (hereinafter referred to as the "Lighting District"); and

WHEREAS, at this time, the City Council desires to initiate proceedings to provide for the annual levy of assessments for the next ensuing fiscal year to provide for costs and expenses necessary to pay for the maintenance of the improvements in said Lighting District; and

WHEREAS, the Solana Beach Lighting Maintenance District Engineer's Report for Fiscal Year 2024/25 (herein referred to as Report), has been presented to and approved by the City Council as a separate action, as required by law, and the City Council desires to continue with the proceedings for said annual levy.

NOW, THEREFORE, the City Council of the City of Solana Beach, California, does resolve as follows:

1. That the above recitals are all true and correct.
2. That the public interest and convenience requires, and it is the intention of this legislative body, to levy and collect assessments to pay the annual costs and expenses for the installation, maintenance and/or servicing of such improvements from those parcels which specially benefit from improvements described below for the above-referenced Lighting District. The improvements are generally described as follows:
 - a. The operation, maintenance and servicing of the following improvements, all within existing public streets, public sidewalks, or public leaseholds of the City.
 - b. Public lighting and street lighting improvements, together with appurtenances.

- c. All improvements are detailed in the City's Street Light Master Plan. No substantial changes in existing improvements or zones are proposed as a part of these proceedings.
3. That said works of improvement are of special benefit to the properties within the boundaries of said Lighting District, which Lighting District the legislative body previously declared to be the area specially benefited by said works of improvement, and for particulars, reference is made to the boundary map as previously approved by this legislative body, a copy of which is on file in the Office of the City Clerk and open for public inspection, and is designated by the name of this Lighting District.
4. That the Solana Beach Lighting Maintenance District Engineer's Report for Fiscal Year 2024/25, as preliminarily approved by this legislative body, is on file with the City Clerk and open for public inspection. Reference is made to the Report for a full and detailed description of the improvements to be maintained, the boundaries of the Lighting District and any zones therein, and the proposed assessments upon assessable lots and parcels of land within the Lighting District.
5. All costs and expenses of the works of maintenance and incidental expenses have been apportioned and distributed to the benefiting parcels in accordance with the special benefits received from the proposed work. The amount assessed on any existing property has not been increased since the 2009/10 Fiscal Year.
6. Notice is hereby given of a public hearing on the 26th day of June, 2024 at 6:00 p.m.
7. At that time, the legislative body will consider and finally determine whether to levy the proposed annual assessment, and to hear all protests relating to said proposed proceedings, or the estimate of the cost and expenses of the proposed maintenance, or the proposed annual assessment; and any and all persons interested may file a written protest at clerkoffice@cosb.org before 12:00 p.m. of the hearing day or, having filed such a protest, may file a written withdrawal of that protest at clerkoffice@cosb.org prior to 12:00 p.m. of such hearing day. Any such written protest must state all grounds for objection. A written protest by a property owner must contain a description sufficient to identify the property owned by such person, e.g. assessor's parcel number.

Any interested person may mail a protest to the following address:

CITY CLERK
CITY OF SOLANA BEACH
635 S. HIGHWAY 101
SOLANA BEACH, CA 92075
clerkoffice@cosb.org

To be considered by the legislative body, all protests must be received by 12:00 p.m. the public hearing date. A postmark prior to such date and time will not be sufficient.

8. That the City Clerk is hereby authorized and directed to give notice as required by law by causing a copy of the Resolution to be published in the newspaper of general circulation within said City; and publication to be completed not less than ten (10) days prior to the date set for the public hearing.

PASSED AND ADOPTED this 22nd day of May, 2024, at a Regular Meeting of the City Council of the City of Solana Beach, California by the following vote:

AYES: Councilmembers –
NOES: Councilmembers –
ABSTAIN: Councilmembers –
ABSENT: Councilmembers –

LESA HEEBNER, Mayor

APPROVED AS TO FORM:

ATTEST:

JOHANNA N. CANLAS, City Attorney

ANGELA IVEY, City Clerk

**CITY OF SOLANA BEACH
LIGHTING MAINTENANCE DISTRICT
ENGINEER'S REPORT
FISCAL YEAR 2024/2025**



**Prepared by:
Dan Goldberg
Principal Civil Engineer
R.C.E. 57292**

Prepared April 26, 2024

TABLE OF CONTENTS

INTRODUCTION	3
GENERAL DESCRIPTION OF THE DISTRICT.....	3
DESIGNATION OF ZONES.....	4
DISTRICT IMPROVEMENT.....	4
METHOD OF APPORTIONMENT	6
DISTRICT FINANCING	6
ASSESSMENT ROLL	6
CALCULATION OF ASSESSMENT FEES	7
EXHIBIT 1 – STREETLIGHT ZONE MAP	8
EXHIBIT 2 – DERIVATION OF STREETLIGHT BENEFIT UNITS.....	9
EXHIBIT 3 – BUDGET 2024-2025.....	11

Introduction

The City of Solana Beach (“City”) Lighting Maintenance District (“District”) was formed to provide funding for operation, maintenance and servicing of all lights within the City, owned both by City of Solana Beach and San Diego Gas and Electric as shown on the City’s Streetlight Master Plan. The City Council, pursuant to the provisions of the “Landscaping and Lighting Act of 1972, Part 2 of Division 15 of the Street and Highway Code of California” (Act), desires to levy and collect annual assessment against lots and parcels within the District beginning in the fiscal year beginning July 1, 2024, and ending June 30, 2025. The collected assessments would pay for the operation, maintenance and servicing of the public lighting improvements within the City. The proposed assessments are based on the City’s estimate for the cost for fiscal year 2024/2025 to maintain the District that provides a special benefit to properties assessed within the District. The assessment rates set for Fiscal Year 2024/2025, as set forth in this Engineer’s Report (“Report”), do not exceed the maximum rates established at the time the District was formed, therefore, the City and the District are not required to go through property owner ballot procedure to establish the 2024/2025 assessment rates. This report describes the District boundaries and the proposed operation, maintenance and services to be assessed to the property owners located within the District. For this Report, each lot or parcel to be assessed refers to an individual property and is assigned its own Assessment Parcel Number (“APN”) by the San Diego County (“County”) Assessor’s Office as shown on the latest equalization roll of the assessor. Following the conclusion of the Public Hearing, the City Council will confirm the Report as submitted or amended and may order the collection of the assessments for Fiscal Year 2024/2025.

General Description of the District

The boundaries of the District are defined as being contiguous with the boundaries of the City of Solana Beach. The properties within the District include single-family residential, multi-family residential, timeshare, multiuse, commercial and industrial parcels.

Section 22573, Landscape and Lighting Act of 1972 (“1972 Act”), requires assessments to be levied according to benefit rather than according to assessed value. This section of the 1972 Act states:

“The net amount to be assessed upon lands within an assessment district may be apportioned by any formula or method which fairly distributes the net amount among all assessable lots or parcels in proportion to the estimated benefits to be received by each such lot or parcel from the improvements.”

The 1972 Act also provides for the classification of various areas within an assessment district into different zones where, "*...by reason of variations in the nature, location, and extent of the improvements, the various areas will receive differing degrees of benefit from the improvements. A zone shall consist of all territory, which will receive substantially the same degree of benefit from the improvements. An assessment district may consist of contiguous or non-contiguous areas.*"

Properties owned by public agencies, such as a city, county, state, or the federal government, are not assessable without the approval of the particular agency. For this reason, they are traditionally not assessed.

Designation of Zones

The District consists of two zones in the City of Solana Beach; Zone "A" and Zone "B". Properties within Zone "A", which represent the majority of the parcels in the City, benefit from streetlights on six significant circulation element streets as well as streetlights on their local streets. Properties within Zone "B", also known as "Dark Sky Zone", do not have streetlights on their local streets. These properties benefit only from streetlights on circulation element streets and do not benefit from streetlights on local streets. A map showing the boundaries of the District and the zones is on file in the office of the City Engineer and is also attached herein as Exhibit 1.

District Improvements

The public lighting improvements to be maintained and serviced include but are not limited to the following:

- Maintenance, repair and replacement of public light poles and fixtures, including changing light bulbs, painting, photoelectric cell repair or replacement, repairing damages caused by automobile accidents and vandalism, and repairing normal deterioration caused by time and weather.
- Electrical conduit repair and replacement due to damage by vandalism and normal deterioration.
- Service-call maintenance repair and replacement including painting, replacing worn out electrical components and repairing damage due to accidents, vandalism, and normal deterioration.
- Payment of the electrical bill for the existing street lighting system.
- Responding to constituent and business inquiries and complaints regarding the public lighting.

Maintenance

The City provides services and furnishes materials for the ordinary and usual maintenance, operation and servicing of public lighting improvements facilities and appurtenant facilities. This includes inspecting lights during daylight as well as evening hours for condition assessment and performing repair, removal or replacement of all or part of any of the streetlights found to be inoperable in order to provide for the health welfare and safety of the residents in the district.

Servicing

The City workforce along with assistance from private contractors provide all labor, materials, equipment and utilities necessary to maintain and operate the public lighting improvements or appurtenant facilities in order to provide adequate illumination.

City's Streetlight System

The City's streetlight system consists of streetlights which are owned by San Diego Gas and Electric (SDG&E) and streetlights that are owned by the City of Solana Beach. A listing (printout) showing the type, size, location and ownership of the specific streetlights in the City is on file in the Office of the City Engineer. There are currently 801 streetlights in the District of which 149 are located on circulation element streets such as Highway 101, Lomas Santa Fe Drive, Via De La Valle, Cedros Avenue, San Andres Drive, Highland Avenue and Stevens Avenue. The remaining 652 streetlights are located on local streets. Approximately 274 streetlights are owned and maintained by SDG&E and the remaining 527 streetlights are owned and maintained by the City of Solana Beach. The City pays SDG&E for the use of their streetlights. For the purpose of this report, all lights have been analyzed regardless of ownership. Additionally, there are 247 bollard lights and 16 pedestrian pole lights on the Coastal Rail Trail that are included in the District.

Streetlight Retrofit

In April 2012, the City entered into an agreement with Chevron Energy Solution (Chevron ES) for a series of energy efficient projects, which included retrofitting all City-owned streetlights to the latest LED technology. This project replaced the approximately two-thirds of the streetlights throughout the City that are owned and operated by the City. The remaining one-third of the streetlights were not retrofitted because they are owned and operated by SDG&E. Because of this partial ownership arrangement, a few streetlights in some neighborhoods remained unchanged.

Capital Improvement Projects

Since the City-owned streetlights were converted to LED fixtures in 2012, there was not a need for a capital improvement project for the streetlights this past year.

Method of Apportionment

The 1972 Act requires that a parcel's assessment may not exceed the reasonable cost for the proportional benefit conferred to that parcel. To establish the benefit to the individual lots or parcels within the district, an Equivalent Benefit Unit ("EBU") system based on land use is used along with special consideration based on City's "Dark Sky Zone". Each parcel of land in the District was determined by the Engineering Department to have a specific land use. Each land use type was assigned a land use factor determined by trip generation rates developed by San Diego Association of Government (SANDAG). If a land use was not included in the SANDAG's study, the Engineering Department made a determination as to its probable trip generation compared to that of a single family residential and assigned a land use factor accordingly. Single-family residential units were assigned a land use factor of 1.0 regardless of its size. The theory is that all single-family residential units, regardless of parcel size, generate approximately the same number of trips and therefore receive the same benefit from the use of streets and their appurtenances such as streetlights. Under this method, vacant lots are assigned an EBU of "0". Exhibit 2 provides the EBU determination for all land uses within the City.

District Financing

The District will be financed by assessing a benefit assessment and by using the District's share of 1.0 percent ad valorem tax revenues. The amount to be generated from the benefit assessment is \$8.80 per benefit unit in Zone "A" and \$1.62 per benefit unit in Zone "B". As mentioned above, the total amount of revenue to be generated by assessment was calculated from a methodology, which identifies two benefit zones within the District. This methodology assumes that circulation element streetlights provide City-wide benefit and therefore properties located in Zone "B", the Dark Sky Zone properties, are assessed for this portion of the District's expenses only. Properties located within Zone "A" are assessed for expenses associated with the streetlights located on the circulation element streets as well as those on local streets. Both the circulation element streetlight benefit and local streetlight benefit are allotted in proportion to the Average Daily Traffic (ADT) generated by properties within the District to establish equivalent benefit charge per property. These are estimates only because the County Assessor's information will not be available until August 2024. The City does not assess governmental agencies owning properties within the District. See Exhibit 3 for the proposed District budget.

Assessment Roll

Parcel identification, for each lot or parcel within the District shall be the parcel as shown on the County Assessor's map for the year in which this Report is prepared.

A listing of parcels assessed within the District, along with the proposed assessment amounts, has been submitted to the City Clerk, under a separate cover, and by reference is made part of this Report. Said listing of parcels to be assessed shall be submitted to the County Auditor/Controller and included on the property tax roll for each parcel in Fiscal Year 2024/2025. If any parcel submitted for collection is identified by the County Auditor/Controller to be an invalid parcel number for the current fiscal year, a corrected parcel number and/or new parcel numbers will be identified and resubmitted to the County Auditor/Controller. The assessment amount to be levied and collected for the resubmitted parcel or parcels shall be based on the method of apportionment and assessment rate approved in this Report. Therefore, if a single parcel has changed to multiple parcels, the assessment amount applied to each of the new parcels shall be recalculated and applied according to the approved method of apportionment and assessment rate rather than a proportionate share of the original assessment.

Calculation of Assessment Fees

Following is a calculation of assessment fees for the Solana Beach Lighting District. There are two zones in this lighting district; Zone “A” and Zone “B”.

Total streetlights on six circulation element streets	149
Total streetlights on local streets	652
Total streetlights	801

Bollard lights on Coastal Rail Trail	247
Pedestrian pole lights on Coastal Rail Trail	16

Total Benefit Units in Zone “A”	8,465
Total Benefit Units in Zone “B”	480

Assessment per Benefit Unit in Zone “A”	\$8.80
Assessment per Benefit Unit in Zone “B”	\$1.62

Total Assessment for Zone “A”	\$74,492
Total Assessment for Zone “B”	\$778

Total Assessment for the District **\$75,270**

EXHIBIT 1

STREETLIGHT ZONE MAP

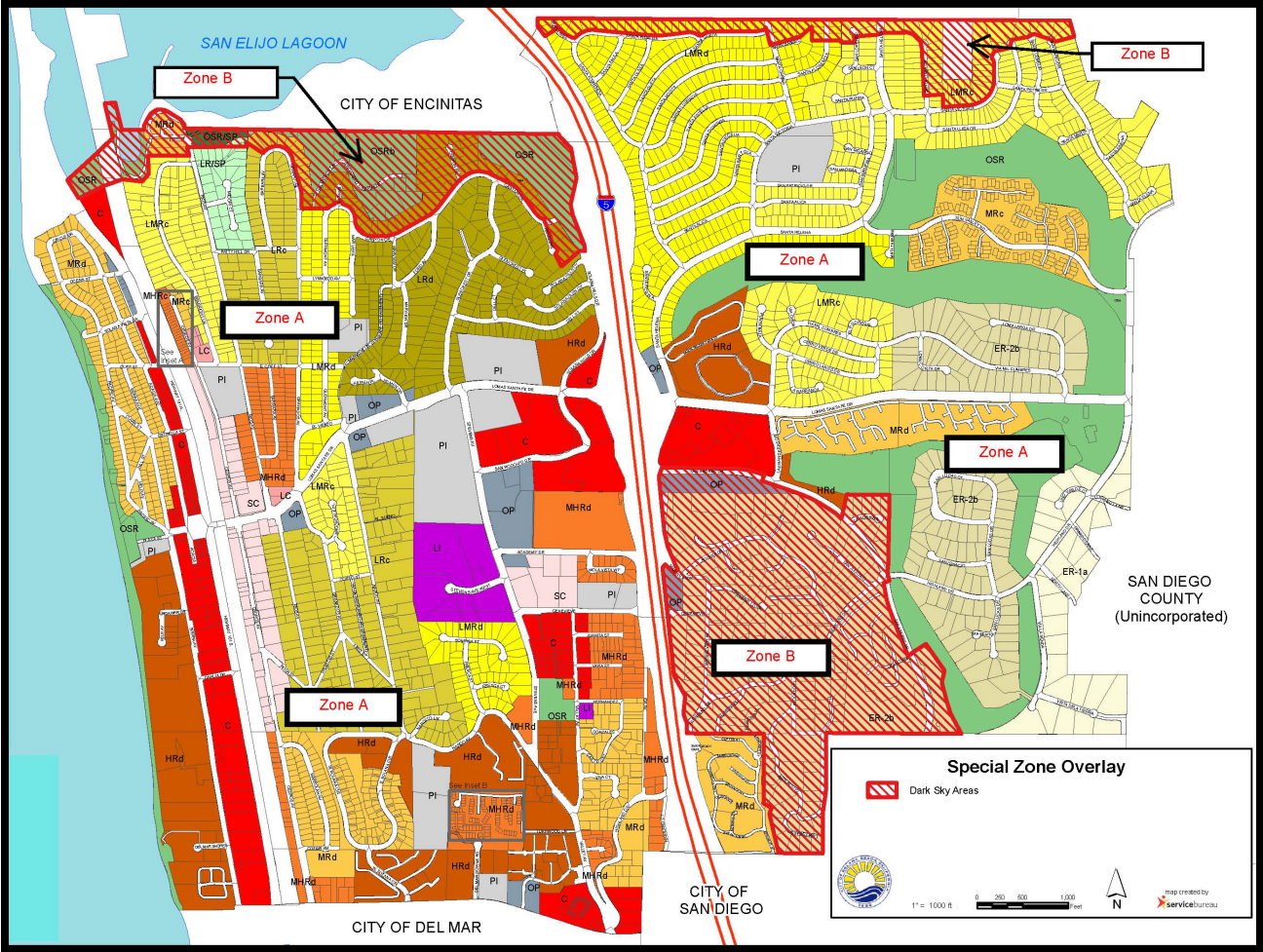

EXHIBIT 2

DERIVATION OF STREETLIGHT BENEFIT UNITS

Traffic generation rates are derived from a report issued by the San Diego Association of Governments (SANDAG) dated April 2002. The information in the report is based on the San Diego Traffic Generators manual. Land uses are defined by the County Assessor. Using traffic generated by single family dwellings as 10 per dwelling unit (d.u.) or 40 per acre, the derivation of Benefit Units from land use is as follows:

<u>LAND USE</u>	<u>BENEFIT UNITS</u>	<u>HOW DERIVED</u>
Vacant Land	0.0	Generates little or no traffic. Assigned a value of 0.0
Residential	1.0/d.u.	<u>10 trips/d.u.</u> 10 trips/d.u.
Time Shares	.02/Time Share	<u>0.2 trips/time share</u> 10 trips/d.u.
Mobilehome/Trailer Parks	0.5/Space	<u>5 trips/d.u. or space</u> 10 trips/d.u.
1-3 Story Misc. Stores	10.0/Acre	<u>400 trips/acre</u> 40 trips/acre
4+ Story Offices/Stores	15.0/Acre	<u>600 trips/acre</u> 40 trips/acre
Regional Shopping Center Medical, Dental, Animal Hospital	12.5/Acre	<u>500 trips/acre</u> 40 trips/acre
Community Shopping Center	17.5/Acre	<u>700 trips/acre</u> 40 trips/acre
Neighborhood Shopping Center	30.0/Acre	<u>1200 trips/acre</u> 40 trips/acre

Hotel, Motel	5.0/Acre	<u>200 trips/acre</u> 40 trips/acre
Convalescent Hospital, Rest Home	1.0/Acre	<u>40 trips/acre</u> 40 trips/acre
Office Condominiums	0.5/Condo	<u>20 trips/condo</u> 10 trips/d.u.
Parking lot, Garage, Used Cars, Auto Sales/Service, Service Station	7.5/Acre	<u>300 trips/acre</u> 40 trips/acre
Bowling Alley	7.5/Acre	<u>300 trips/acre</u> 40 trips/acre

EXHIBIT 3

STREETLIGHT DISTRICT

PROPOSED BUDGET

FISCAL YEAR 2024-25

	Amended Budget 2023-24	Adopted Budget 2024-25
COSTS		
Energy	\$118,500	\$120,000
Maintenance	365,648	376,993
Administration	270,443	279,875
Capital Outlay	0	0
Debt Service	70,375	70,375
Contingency Reserve	3,457,689	3,380,498
TOTAL COSTS	\$4,282,655	\$4,227,741

FUNDING		
Property Taxes	\$634,482	\$640,827
Benefit Fees	76,006	76,500
Interest	42,525	42,525
Intergovernmental	10,200	10,200
Fund Balance	3,519,442	3,457,689
TOTAL RESOURCES	\$4,282,655	\$4,227,741



STAFF REPORT CITY OF SOLANA BEACH

TO: Honorable Mayor and City Councilmembers
FROM: Alyssa Muto, City Manager
MEETING DATE: May 22, 2024
ORIGINATING DEPT: Public Works Department
SUBJECT: **City Council Consideration of Resolution 2024-060 Ratifying the Interim City Manager’s Decision to Execute Change Order No. 1 to the Construction Contract for Exterior Painting and Stucco Repairs at City Hall with Polychrome Construction, Inc., Accept this Project as Complete and Authorize the City Clerk to File a Notice of Completion**

BACKGROUND:

The City of Solana Beach City Hall building was last painted in 2007 and was in need of exterior painting and stucco repairs. Due to the coastal environment, exterior painting and stucco repairs were necessary, as the City Hall building provides essential services to the community. The Adopted Budget for Fiscal Year 2023/2024 appropriated \$125,000 in the Capital Improvement Program (CIP) for exterior painting and stucco repairs for the City Hall Facility.

In October 2023, Staff issued a Request for Bids (RFB), Bid No. 2023-10, via an electronic bid site to solicit proposals from firms qualified to provide painting and stucco repair services. Seven bids were received by the closing date. On November 14, 2023, at 2:00 p.m., the City Clerk’s Office opened the bids and read them publicly.

On December 13, 2023, the City Council authorized the City Manager to enter into a construction contract with Polychrome Construction, Inc. (Polychrome) for painting and stucco repairs at City Hall, Resolution 2023-131.

This item is before the City Council for the consideration of Resolution 2024-060 (Attachment 1) that would ratify the Interim City Manager’s decision to execute Change Order No. 1 to the construction contract with Polychrome, report the final project costs, accept the project as complete and direct the City Clerk to file a Notice of Completion (NOC).

CITY COUNCIL ACTION:

DISCUSSION:

During the stucco repair process, it was discovered that additional measures were needed to protect the building from moisture infiltration. Polychrome recommended the use of the Tremco Solargard Hy-Build Fibrous Elastomeric (Tremco) product, a high-quality product known for its effectiveness in waterproofing and moisture protection. In several instances, and especially during the 2024 storm events, water intrusion caused significant damage to the City Hall building, such as carpet, drywall, and tile damage, leading to costly repairs. Utilizing the Tremco's waterproofing solutions would have effectively prevented many, if not most, of these issues by providing a durable barrier against moisture penetration. After careful consideration, the Interim City Manager decided to approve the use of the Tremco product for this purpose. This decision was made based on the contractor's expertise and the product's proven track record in similar projects. A copy of Change Order No. 1 is included with this Staff Report as Attachment 2.

The Interim City Manager's approval reflects a commitment to ensuring the longevity and structural integrity of the building, which ultimately benefits the community and City Staff by reducing the risk of future moisture-related issues. Although the amount of the change order was outside Interim City Manager's limit as detailed in Section 3.08.105 (B) of the Solana Beach Municipal Code, due to the short time frame for completion of this project (one week), there was not sufficient time to obtain City Council approval of the change order without unduly delaying the contractor and completion of the project.

Polychrome Construction, Inc., completed all work on this project in accordance with the approved plans and specifications of Bid No. 2023-10 to the satisfaction of the City Engineer on May 3, 2024.

CEQA COMPLIANCE STATEMENT:

Exempt pursuant to Section 15301(a) of the State CEQA Guidelines.

FISCAL IMPACT:

The Adopted Budget for Fiscal Year 2023/2024 appropriated \$125,000 in the Capital Improvement Program (CIP) for exterior painting and stucco repairs for the City Hall Facility.

The City Council approved a construction contract with Polychrome Construction, Inc., in the amount of \$47,745, and a recommended contingency amount of \$7,161 (15%), for a total amount of \$54,906.

City Staff is recommending that the City Council ratify the Interim City Manager's decision to approve the use of the Tremco product, at a cost of \$39,085, bringing the final contract

amount to \$86,830. Please note that there was a remaining balance of \$70,094 for FY 2023/24 in the CIP project fund would more than offset this additional expenditure.

WORK PLAN:

Since this project was listed in the Capital Improvement Program section of the Fiscal Year 2023/2024 Adopted Budget, this project is consistent with the item in the Workplan for "Capital Project Construction Management".

OPTIONS:

- Approve Staff recommendation.
- Approve Staff recommendations with modifications.
- Provide alternative direction to Staff.

DEPARTMENT RECOMMENDATION:

Staff recommends that the City Council adopt Resolution 2024-060:

1. Ratifying the City Manager's decision to execute Change Order No. 1 to the construction contract with Polychrome Construction, Inc., in an amount of \$39,085, for a total amount of \$86,830, for Fiscal Year 2023/24.
2. Authorizing the City Clerk to file a Notice of Completion.

CITY MANAGER'S RECOMMENDATION:

Approve Department Recommendation.

Alyssa Muto, City Manager

Attachments:

1. Resolution 2024-060
2. Change Order No. 1

RESOLUTION 2024-060

A RESOLUTION OF THE CITY COUNCIL OF THE CITY OF SOLANA BEACH, CALIFORNIA, RATIFYING THE INTERIM CITY MANAGER'S DECISION TO EXECUTE CHANGE ORDER NO. 1 TO THE CONSTRUCTION CONTRACT FOR EXTERIOR PAINTING AND STUCCO REPAIRS AT CITY HALL WITH POLYCHROME CONSTRUCTION, INC., ACCEPT THIS PROJECT AS COMPLETE AND AUTHORIZE THE CITY CLERK TO FILE A NOTICE OF COMPLETION

WHEREAS, the City of Solana Beach City Hall building needed exterior painting and stucco repairs. The City Hall building was last painted in 2007; and

WHEREAS, in October 2023, Staff issued a Request for Bids (RFB), Bid No. 2023-10, via an electronic bid site to solicit proposals from firms qualified to provide painting and stucco repair services. Seven bids were received by the closing date of November 14, 2023; and

WHEREAS, on December 13, 2023, the City Council authorized the City Manager to enter into a Construction Contract with Polychrome Construction, Inc. (Polychrome) for painting and stucco repairs at City Hall, Resolution 2023-131; and

WHEREAS, during the construction process, it was discovered that additional measures were needed to protect the building from moisture infiltration. Polychrome recommended the use of the Tremco Solargard Hy-Build Fibrous Elastomeric product, a high-quality product known for its effectiveness in waterproofing and moisture protection; and

WHEREAS, in several instances, and especially during the 2024 storm events, water intrusion caused significant damage to the City Hall building, such as carpet, drywall, and tile damage, leading to costly repairs. Utilizing the Tremco's waterproofing solutions would have effectively prevented many, if not most, these issues by providing a durable barrier against moisture penetration; and

WHEREAS, the Fiscal Year 2023/2024 Adopted Budget appropriated \$125,000 in the Capital Improvement Program (CIP) for exterior painting and stucco repairs for the City Hall building; and

WHEREAS, the City Council approved a construction contract with Polychrome Construction, Inc., in the amount of \$47,745, and a recommended contingency amount of \$7,161 (15%), for a total amount of \$54,906; and

WHEREAS, City Staff recommended that the City Council ratify the Interim City

Manager's decision to approve the use of the Tremco product, at a cost of \$39,085, bringing the not to exceed amount to \$86,830.

NOW, THEREFORE, the City Council of the City of Solana Beach, California, does resolve as follows:

1. That the foregoing recitations are true and correct.
2. That the City Council ratifies the Interim City Manager's decision to execute Change Order No. 1 to the construction contract with Polychrome Construction, Inc., in an amount of \$39,085, for a total amount of \$86,830, for Fiscal Year 2023/24.
3. That the City Council authorizes the City Clerk to file a Notice of Completion.

PASSED AND ADOPTED at a regular meeting of the City Council of the City of Solana Beach, California, held on the 22nd day of May 2024 by the following vote.

AYES: Councilmembers –
NOES: Councilmembers –
ABSENT: Councilmembers –
ABSTAIN: Councilmembers –

LESA HEEBNER, Mayor

APPROVED AS TO FORM:

ATTEST:

JOHANNA N. CANLAS, City Attorney

ANGELA IVEY, City Clerk

**CITY OF SOLANA BEACH
CONTRACT CHANGE ORDER**

Date May 7, 2024

Project: City Hall Exterior Painting and Stucco Repairs

Change Order 1

Purchase Order # 22400169

PROJECT TITLE: City Hall Exterior Painting and Stucco Repairs, Bid No. 2023-10

This change order compensates the contractor for the items listed below. Request for Change Order No. 1 dated May 7, 2024 (attached).

1. Recommended application of Tremco Solargard Hy-Build Fibrous Elastomeric to mitigate and protect against unwanted water intrusion. Price includes all Material, Prevailing wage Labor and Boom Lifts

**TOTAL CHANGE TO CONTRACT AMOUNT: \$39,085.00
CHANGE TO CONTRACT WORKING DAYS: 0**

All work related to this change order shall be done in accordance with the Project Special Provisions, the Project Plans, and the Standard Specifications for Public Works Construction "Greenbook", 2018 Edition (Standard Specifications). This change order shall include all labor, materials, tools, equipment and incidentals as required to complete the work complete and in place. No additional compensation shall be due to the contractor as a result of this change order.

This change order shall include all general contractor's overhead, extended overhead, profit, incidentals, bonds and lost time. Contractor shall not be entitled to any additional payments or time extensions beyond what is detailed in this change order.

Estimated Cost: Increase **\$39,085.00** Decrease -- No Change --

By reason of this change order the time of completion will be extended by -0- days.

Recommended By: _____
Mohammad Sammak, City Engineer

Contract Summary

Approved: CITY OF SOLANA BEACH

Initial Contract Amount \$47,745.00

By: _____
Daniel King, Interim City Manager

Date: _____

This Change Order \$39,085.00

Approved: POLYCHROME CONST.

Total Contract to Date \$86,830.00

By: _____

Date: _____

Additional Appropriation Required No



April 26, 2024

From: Polychrome Construction Inc.
8908 Balboa Blvd. Northridge, CA. 91325
Lic # 993826
DIR# 1000020697

To: City of Solana Beach
635 Hwy 101,
Solana Beach, CA 92075

Att: Mr. Mo Sammak
Principal Engineer

RE: Tremco Waterproofing Material Coating for Selected walls of City Hall

PROPOSAL

Dear Mr. Sammak,

Submitted herewith is our proposal for the Exterior waterproofing of selected exterior walls as per our site visit on April 25, 2024. After examining the areas of the exterior walls that appear to have the water intrusion issue, we are suspecting that the walls are failing to protect the building from water penetration at the upper rooftop areas where the wall fuses into what can be considered a partial roof. When rainfall conditions exist, the rain hits the horizontal surface area of the wall/roof of the building at a higher velocity than the vertical part of the wall therefore encouraging water penetration to occur. It appears that those areas of the walls that take a curvature are prone to conditions that a proper roof would encounter therefore a suitable roofing-like coating should mitigate the water intrusion problem.

We recommend the **Tremco Solargard Hy-Build Fibrous Elastomeric**. It is a water-based, acrylic, elastomeric roof and wall coating formulated to provide a tough, durable, flexible, breathable film protection of previously painted or unpainted masonry walls.

The walls to receive the **Tremco Solargard Hy-Build** will be power washed to remove all dirt, debris, algae, and dust in order to create a clean substrate for the coating to adhere to. Any loose or peeling paint and damaged stucco will be scraped and removed, and any cracks will be filled with elastomeric caulking and stucco patch to blend with the existing texture. (This cleaning and prepping procedure is documented here as a formality and the city is not being charged for it in this quote as it is already included in the painting contract that already exists).

Once the surfaces are prepped, they will receive a coat of **Tremco Solargard Hy-Build** in white to a mil thickness of 24 wet mils. Once the Material is dry (usually 24 hr wait time) then it will be ready to be top coated with the Loxon Flat paint (this is part of the original painting contract and separate of this quote).

Price includes all Material, Prevailing wage Labor and Boom Lifts. **\$ 39,085.00**

(Thirty-Nine Thousand and Eighty-Five Dollars and Zero cents)

Regards,

Marios Polychronas
President
Polychrome Construction Inc

8908 Balboa Blvd, Northridge, CA 91325 818-831-8308 Fax 818-775-9944 License # 993826

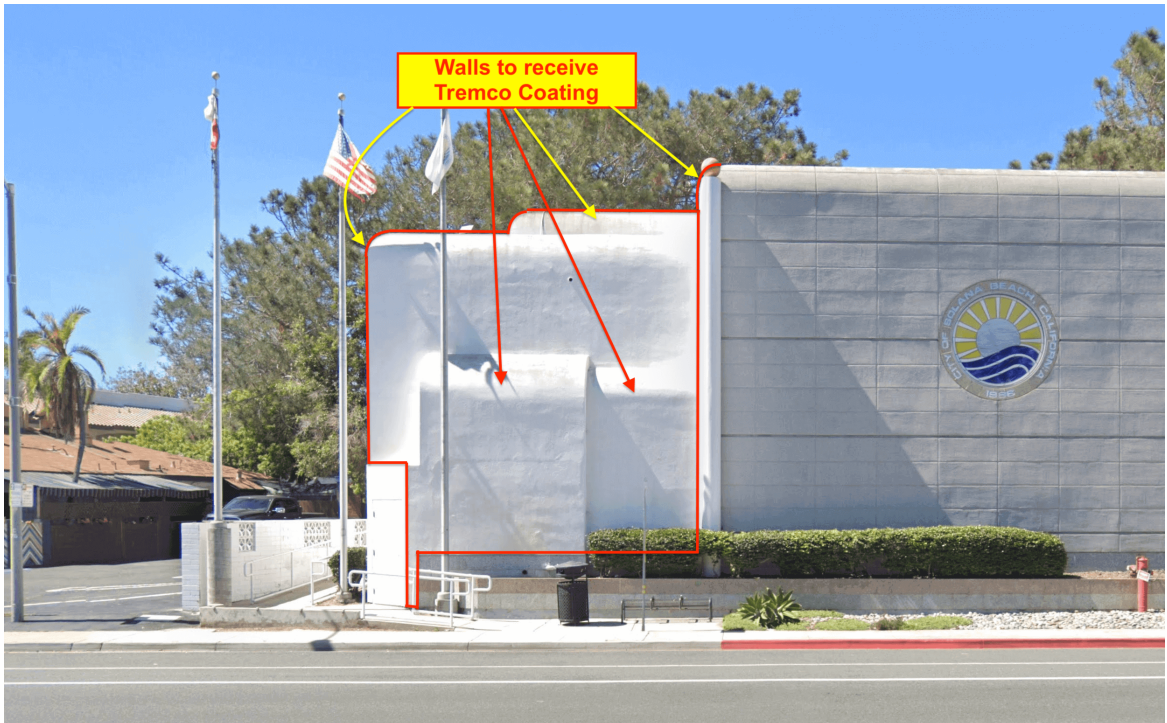







**Wall to
receive
Tremco
Coating**

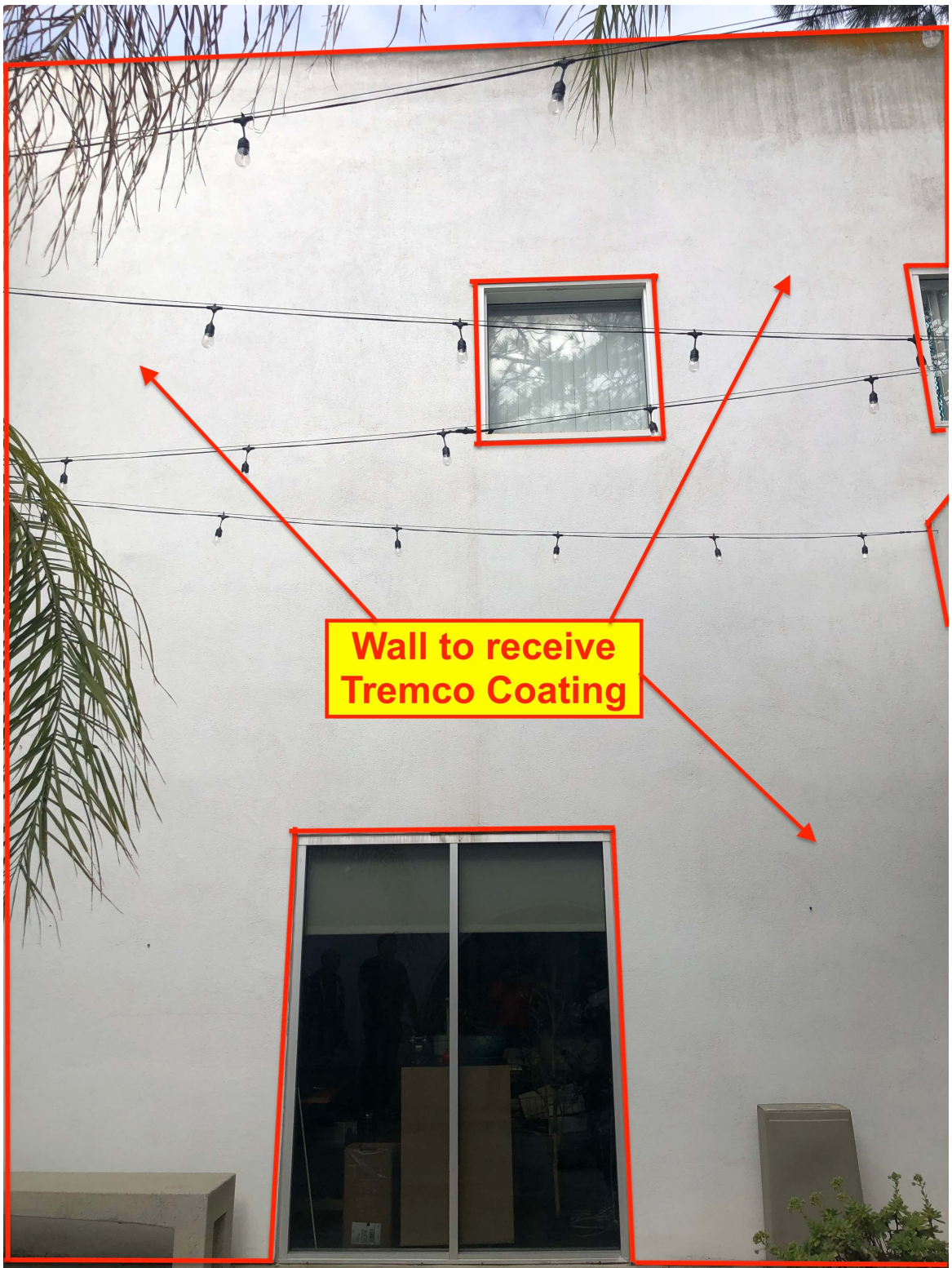

**Wall to receive
Tremco Coating**



STAFF REPORT

CITY OF SOLANA BEACH

TO: Honorable Mayor and City Councilmembers
FROM: Alyssa Muto, City Manager
MEETING DATE: May 22, 2024
ORIGINATING DEPT: Community Development Department
SUBJECT: **Public Hearing: Request for a Time Extension for an Approved Conditional Use Permit Modification for the Construction of a 60-Foot-Long Drilled Micropile/Caisson Return Wall at the Southern Terminus of the Seawall on the Coastal Bluff Below 135 S. Sierra Avenue, Solana Beach. Case No: TE23-002; Applicant: Las Brisas HOA, APN: 298-010-51-01 to 36 Resolution 2024-029**

BACKGROUND:

The Applicant, Las Brisas Homeowners Association, is requesting a 12-month time extension to the Conditional Use Permit Modification (CUP mod.) originally approved on February 9, 2022, with the adoption of Resolution 2022-013, to construct a Bluff Retention Device (BRD) consisting of a return wall that would extend from the top of the southern terminus of the existing seawall approximately 60 feet to the top of the bluff. The shotcrete wall would be constructed with a drilled micropier/caisson design with structural concrete between piers. The exposed areas of the wall would be covered with hand sculpted, colored shotcrete to match the natural bluff surface and color. Areas of failed mid-to upper-bluff, north of the wall, will be reconstructed with geogrid and soil and covered with a hydroseed application that would utilize drought resistant, salt tolerant native species. The return wall would encapsulate and restore the bluff to an acceptable factor of safety for the existing residential structures onsite at 135 S. Sierra Avenue. The project would also allow public pedestrian access and public agency vehicle access near the top of the bluff that is currently closed.

The project was set to expire 24 months from the original approval date; therefore, it was set to expire February 9, 2024. The Applicant applied for the extension request on December 7, 2023. The permit expiration is considered to be on hold until the City Council is able to make a determination on the project.

COUNCIL ACTION:

This item is before the City Council to consider adoption of Resolution 2024-028 (Attachment 1) approving the Applicant's request to formally extend the project approval as provided under the Solana Beach Municipal Code (SBMC) 17.72.110 for 12 months starting from the original expiration date of February 9, 2024.

DISCUSSION:

In 2022, the City Council adopted Resolution 2022-013 conditionally approving a CUP mod. for the construction of the BRD and upper bluff restoration. The previous City Council agenda packet has been provided for reference in Attachment 2.

Prior to the expiration date, the Applicant had obtained California Coastal Commission (CCC) approval of the project and had obtained a grading permit issued by the City of Solana Beach. When holding a pre-construction meeting onsite, the contractor the Applicant had retained to perform the work backed out of the contract due to the conditions of the site. The Applicant had to find and retain another qualified contractor to do the work. Once a new contractor was retained, new engineering plans had to be drawn up as the previous firm retained the ownership of the previous plans. The Applicant determined they were not going to be able to complete this prior to the discretionary expiration date, therefore, they requested the project extension.

The approval under Resolution 2022-013 was set to expire on February 9, 2024. The Applicant submitted a formal application on December 7, 2023, more than 60 days before the expiration date in accordance with SBMC Section 17.72.110. The Code indicates that:

One or more (but not more than a total of four) extensions may be granted not exceeding a cumulative total of 24 months after the date the original approval of the project expires. The duration of an extension shall be in an increment of 30 days. The minimum duration of an extension shall be six months. The maximum duration of an extension shall not be more than 12 months. The duration of an extension shall be determined at the discretion of the issuing authority.

The Applicant is requesting to extend the expiration by 12 months to February 9, 2025, due to the unique circumstances of the project and the restricted construction times for coastal bluff projects. The extension would allow the Applicant sufficient time to process a revision to the CCC permit and the grading permit, if necessary, obtain authorization from the CCC and the associated grading permit required by the City and start construction. The project extension application (Attachment 4) indicates how they will use the 12-month extension period to obtain the required permits and commence construction.

SBMC Section 17.72.110 establishes that City Council action is required to review and act on a request for an extension of a CUP mod. when City Council was the original approving body. The City Council may extend the approval of a project if they are able to make the seven (7) required findings, which are as follows:

1. *The applicant has presented facts which establish that the applicant has timely and diligently pursued issuance of a building permit during the 24-month period following the issuance of the original approval for the project (or the different period set forth as a condition of approval of the project) or during the then current extension period;*
2. *Circumstances beyond the applicant’s control have intervened and prevented the applicant from obtaining the issuance of a building permit for the project prior to expiration of the 24-month period (or the expiration date established as a condition of the approval) or during the then current extension period;*
3. *The application for the extension sets forth a reasonable and substantial factual basis for issuance of the extension;*
4. *There is a substantial factual basis to determine that the applicant will be able to perform the actions necessary to obtain issuance of a building permit prior to expiration of the requested extension;*
5. *The duration of the extension requested by the applicant is no longer than is reasonably necessary to perform the actions necessary to obtain the issuance of a building permit;*
6. *There have not been any significant changes in the general plan, applicable specific plan, if any, zoning, or character of the area within which the project is located that would cause the approved project to become inconsistent, incompatible, or nonconforming therewith; and*
7. *The granting of an extension shall not be detrimental to the public health, safety, or welfare, or materially injurious to properties or improvements in the vicinity.*

The draft Resolution of Approval has been prepared by Staff for the consideration of the City Council. The draft Resolution is based upon the information provided in this report. The City Council may direct Staff to modify Resolution 2024-029 to reflect the findings and conditions it deems appropriate as a part of the public hearing process. In the alternative, if the City Council determines the request is to be denied, Staff will prepare a Resolution of Denial for an action to be taken at a subsequent City Council meeting.

Notices of a Public Hearing for this project were mailed to property owners and occupants within 300 feet of the project site more than 10 days prior to the City Council date. As of the date of preparation of this Staff Report, no phone calls, letters, or emails have been received by Staff in regard to the extension request.

CEQA COMPLIANCE STATEMENT:

Time Extensions are not a project as defined by CEQA. The original project was found exempt pursuant to the 2022 State of California CEQA Guidelines Sections 15269.

FISCAL IMPACT: N/A

WORK PLAN: N/A

OPTIONS:

- Approve the requested time extension and minor modifications.
- Deny the request for a time extension and minor modifications.
- Provide direction to Staff.

DEPARTMENT RECOMMENDATION:

Staff recommends that the City Council:

1. Conduct the Public Hearing: Open the Public Hearing, Report Council disclosures, Receive Public testimony, Close the Public Hearing.
2. If the City Council can make the required findings, adopt Resolution 2024-029, approving the request for a Time Extension for approvals and entitlements in Case No. CUP20-004 and setting the expiration date as February 9, 2025.

CITY MANAGER'S RECOMMENDATION:

Approve Department Recommendation



Alyssa Muto, City Manager

Attachments:

1. Resolution 2024-029
2. Original Public Hearing Package
3. New Project Plans
4. Extension Request Application

RESOLUTION 2024-029

A RESOLUTION OF THE CITY COUNCIL OF THE CITY OF SOLANA BEACH, CALIFORNIA, CONDITIONALLY APPROVING A TIME EXTENSION TO A PREVIOUSLY APPROVED CONDITIONAL USE PERMIT MODIFICATION FOR THE CONSTRUCTION OF A MICROPILE RETURN WALL, MID-AND UPPER-BLUFF RESTORATION AND LANDSCAPING BELOW 135 S. SIERRA AVENUE IN SOLANA BEACH

APPLICANT: LAS BRISAS
CASE NO.: TE23-002 TIME EXTENSION
APN: 298-010-51-01 to 36

WHEREAS, the Las Brisas Homeowners Association (hereinafter referred to as “Applicant”) has submitted a request for a time extension of the approved Development Review Permit (DRP) and Structure Development Permit (SDP) pursuant to Title 17 (Zoning), of the Solana Beach Municipal Code (SBMC); and

WHEREAS, the City Council adopted Resolution 2022-013 approving the project at the regularly scheduled February 9, 2022, City Council meeting; and

WHEREAS, the original discretionary approval was set to expire on February 9, 2024; and

WHEREAS, the Applicant submitted a request for a 12-month extension of the project approval; and

WHEREAS, on May 22, 2024, the City Council held a duly noticed Public Hearing to consider the time extension request and minor modifications; and

WHEREAS, the Public Hearing was conducted pursuant to the provisions of SBMC 17.72.030 of the Solana Beach Zoning Ordinance; and

WHEREAS, at the Public Hearing, the City Council received and considered evidence concerning the request for a Time Extension; and

WHEREAS, the City Council of the City of Solana Beach found that a Time Extension Request is not a project according to the State California Environmental Quality Act (CEQA) Guidelines; however, the City Council found that the original project was found exempt pursuant to the 2022 State of California CEQA Guidelines Section 15269; and

WHEREAS, this decision is based upon the evidence presented at the Hearing, and any information the City Council gathered by viewing the site and the area as disclosed at the Hearing.

NOW THEREFORE, the City Council of the City of Solana Beach, California, does resolve as follows:

1. That the foregoing recitations are true and correct.
2. That the request for a 12-month Time Extension for a Conditional Use Permit Modification to construct a Bluff Retention Device (BRD) consisting of a return wall with a drilled pier/caisson design with structural concrete between the piers covered with hand sculpted, colored shotcrete would extend from the top of the southern terminus of the seawall approximately 60 feet to the top of the bluff is conditionally approved based on the following:
3. FINDINGS:
 - A. In accordance with Section 17.72.110 (Lapse of Approval and Extensions) of the City of Solana Beach Municipal Code, the City Council finds the following:
 - I. *The Applicants have presented facts which establish that the Applicants have timely and diligently pursued issuance of a building permit during the 24-month period following the issuance of the original approval for the project;*
 - II. *Circumstances beyond the Applicants' control have intervened and prevented the Applicants from obtaining the issuance of a building permit for the project prior to expiration of the 24-month period following the issuance of the original approval for the project;*
 - III. *The application for the extension sets forth a reasonable and substantial factual basis for issuance of the time extension;*
 - IV. *There is a substantial factual basis to determine that the Applicants will be able to perform the actions necessary to obtain issuance of a building permit prior to expiration of the requested extension;*
 - V. *The duration of the time extension requested by the Applicants is not longer than is reasonably necessary to perform the actions necessary to obtain the issuance of a building permit;*
 - VI. *There have not been any significant changes in the general plan, applicable specific plan, if any, zoning, or character of the area within which the project is located that would cause the approved project to become inconsistent, incompatible, or nonconforming therewith; and*

VII. *The granting of an extension shall not be detrimental to the public health, safety, or welfare, or materially injurious to properties or improvements in the vicinity.*

1. CONDITIONS:

Prior to use or development of the property in reliance on this permit, the Applicant shall provide for and adhere to the conditions of the original project approval of Resolution 2022-013.

2. ENFORCEMENT: Pursuant to SBMC 17.72.120(B) failure to satisfy any and all of the above-mentioned conditions of approval is subject to the imposition of penalties as set forth in SBMC Chapters 1.16 and 1.18 in addition to any applicable revocation proceedings.

3. EXPIRATION: The Conditional Use Permit for the project will expire 12 months from the date of expiration of the original project approval, unless the Applicant has obtained building permits and have commenced construction prior to that date, and diligently pursued construction to completion.

4. INDEMNIFICATION AGREEMENT: The Applicant shall defend, indemnify, and hold harmless the City, its agents, officers, and employees from any and all claims, actions, proceedings, damages, judgments, or costs, including attorney's fees, against the City or its agents, officers, or employees, relating to the issuance of this permit including, but not limited to, any action to attack, set aside, void, challenge, or annul this development approval and any environmental document or decision. The City will promptly notify the Applicant of any claim, action, or proceeding. The City may elect to conduct its own defense, participate in its own defense, or obtain independent legal counsel in defense of any claim related to this indemnification. In the event of such election, the Applicant shall pay all of the costs related thereto, including without limitation reasonable attorney's fees and costs. In the event of a disagreement between the City and Applicant regarding litigation issues, the City shall have the authority to control the litigation and make litigation related decisions, including, but not limited to, settlement or other disposition of the matter. However, the Applicant shall not be required to pay or perform any settlement unless such settlement is approved by the Applicant.

NOTICE TO APPLICANTS: Pursuant to Government Code Section 66020, you are hereby notified that the 90-day period to protest the imposition of the fees, dedications, reservations or other exactions described in this Resolution commences on the effective date of this resolution. To protest the imposition of any fee, dedications, reservations or other exactions described in this Resolution you must comply with the provisions of Government Code Section 66020. Generally the Resolution is effective upon expiration of the tenth day following the date of adoption of this Resolution, unless the resolution is appealed or called for review as provided in the Solana Beach Zoning Ordinance.

PASSED AND ADOPTED at a regular meeting of the City Council of the City of Solana Beach, California, held on the 22th day of May, 2024, by the following vote:

AYES: Councilmembers –
NOES: Councilmembers –
ABSENT: Councilmembers –
ABSTAIN: Councilmembers –

LESA HEEBNER, Mayor

APPROVED AS TO FORM:

ATTEST:

JOHANNA N. CANLAS, City Attorney

ANGELA IVEY, City Clerk



STAFF REPORT CITY OF SOLANA BEACH

TO: Honorable Mayor and City Councilmembers
FROM: Gregory Wade, City Manager
MEETING DATE: February 9, 2022
ORIGINATING DEPT: Community Development Department
SUBJECT: Request for a Conditional Use Permit for the Construction of a Bluff Retention Device at 135 S. Sierra Avenue, Solana Beach. Case No: CUP 17-17-27; Applicant: Las Brisas Homeowners Association Resolution 2022-013.

BACKGROUND:

The Applicant, the Las Brisas Homeowners Association, is requesting the approval of a Conditional Use Permit (CUP) to construct a Bluff Retention Device (BRD) consisting of a return wall that would extend from the top of the southern terminus of the existing seawall to the top of the bluff approximately 60 feet. The shotcrete wall would be constructed with a drilled pier/caisson design with structural concrete between piers. Exposed areas of the wall would be covered with hand sculpted, colored shotcrete to match the natural bluff surface and color. Areas of failed mid to upper bluff to the north of the wall will be reconstructed with geogrid and soil and covered with a hydroseed application that would utilize drought resistant, salt tolerant native species. The return wall would encapsulate and restore the bluff to an acceptable factor of safety for the existing residential structures onsite at 135 S. Sierra Avenue. The project would also allow public pedestrian access and public agency vehicle access near the top of the bluff that is currently closed.

This issue before the City Council is whether to approve, approve with conditions or deny the Applicant's request for a Conditional Use Permit (CUP) as contained in Resolution 2022-013 (Attachment 1).

DISCUSSION:

The existing approximately 2.19-acre property is developed with two four-story and one three-story condominium buildings, a one-story clubhouse, a swimming pool, a tennis court and associated underground utilities, retaining walls and vehicular and pedestrian hardscape and landscaping. At the closest point, the separation between the foundation of the

CITY COUNCIL ACTION:
Resolution 2022-013
Approved 4/0/1 with Modification Absent: Zito

AGENDA ITEM # B.1.

ATTACHMENT 2

westernmost condominium building (building 3) and the coastal bluff edge is approximately 27 feet.

The lower coastal bluff is protected by an existing Bluff Retention Device (BRD)/seawall that is approximately 120 feet long and 35 feet high that is restrained with three rows of 75-foot-long tiebacks and covered by hand-sculpted and colored shotcrete. Above the wall, geogrid reinforced fill was placed on top of the BRD to an approximate elevation of 45 feet above Mean Sea Level (MSL) to create a transition between the top of the BRD and the upper bluff. The City Council approved a Conditional Use Permit to construct the BRD/Seawall in 2004 with the adoption of Resolution 2004-171.

In 2010, a significant failure occurred along the section of lower coastal bluff beginning at the southern terminus of the Las Brisas seawall and extending south approximately 70 feet across the unprotected bluff face along the Surfsong Condominium Association property line. Undercut depths in the failure area had reached depths of 5 to 8 feet. The failure occurred along a joint at the base of the undercut area. According to the application, this failure resulted in a loss of 5 to 8 feet in depth of the coastal bluff adjacent to the Surfsong property. The failure exposed approximately 7 to 8 feet of the southern end of the Las Brisas seawall.

In 2010, the Applicant requested and received approval of a Development Review Permit to construct a new segment of seawall that was an 8 foot long, 2.5 foot wide and 35 foot tall lateral return wall at the south end of the existing 120 foot long, 35 foot high seawall under an Emergency Permit. The Emergency Permit was issued by the California Coastal Commission as it was found to be the least amount of work necessary to restore the design parameters of the existing seawall and assure the factor of safety for the blufftop residences remains consistent with that provided by the seawall.

After the completion of the work, the Applicant was required to submit monitoring reports annually for the first three years and then every three years for the life of the BRD. In the 2012 monitoring report, it was noted that the exposure of the clean sand lens had expanded to the north and behind the seawall approximately seven feet north of the Las Brisas southern property line. The report indicated that this concern could expand further with time and on-going monitoring was advised. In the 2015 report, there was minor progression of erosion at the northern end of the seawall at the level of the exposed clean sand lens.

In 2019, there was a significant failure immediately south of the existing seawall. This failure has undergone progressive headward retreat since that time which has impacted a recorded easement for public agency vehicles, including emergency vehicles. As a result, public pedestrian access from Fletcher Cove across the Las Brisas Property into a public open space area on the adjacent Surfsong Condominium property to the south has been closed. As indicated in the geotechnical reports provided by the Applicant and reviewed by the City's third-party geotechnical engineer, the proposed project would fully encapsulate the Las Brisas Property and return the property to a level of safety that would allow the City to reopen the rear of the property to pedestrian and public agency vehicular access. Project plans have been provided in Attachment 2.

The proposed project design is consistent with portions of Figure 3 and Figure 5, Appendix B included as Attachment 3 in the City's Certified Land Use Plan (LUP) which depicts the City's preferred engineered solution for a coastal bluff experiencing active lower, mid and upper bluff erosion.

This CUP application is before the City Council because the bluff area located below and along the project site has been determined to meet the criteria of imminent failure. The generally accepted factor of safety calculation for purposes of determining bluff stability and the potential for imminent failure is a factor of safety of 1.2 or less. The factors of safety onsite range from 1.021 to 1.19, thus meeting the criteria for imminent failure.

The existing conditions are the result of several factors including, but not limited to, recent failures immediately adjacent to these properties and the exposure of the clean sand lens which both result in undermining of the existing seawall. Las Brisas was advised that this will be a reoccurring issue due to the continued failure of the exposed clean sand lens at the southerly terminus.

Table 1, below, demonstrates the existing factor of safety versus the factor of safety with proposed project improvements under both static and seismic conditions. A factor of safety equal to or less than 1.0 represents a slope that is structurally failing whereby the bluff top principal structures are considered in "imminent danger" from potential bluff collapse and/or failure.

TABLE 1 - FACTOR OF SAFETY			
Structure	Distance to bluff edge	Existing: Static Factor of Safety	With Project: Static and Seismic Factor of Safety
Public Easement/Public Agency Vehicle Access:	0-10 feet	1.021	1.5/1.1
Las Brisas Condominium Building 3:	27 feet	1.19	1.5/1.1

Solana Beach Local Coastal Program

A consistency finding with the City's Local Coastal Program (LCP) Land Use Plan (LUP) is required for the proposed project. The City's LUP policies were certified to be consistent with Coastal Act Section 30235 which states: *Revetments, breakwaters, groins, harbor channels, seawalls, cliff retaining walls, and other such construction that alters natural shoreline processes shall be permitted when required to serve coastal-dependent uses or to protect*

existing structures or public beaches in danger from erosion, and when designed to eliminate or mitigate adverse impacts on local shoreline sand supply.

Applicable City policies from the City's Certified LUP (as amended) are listed below followed by a discussion of how the project complies or has been conditioned to comply with the City's applicable and relevant LUP policies.

- Certified LUP Policy 4.26 (irrigation controls for bluff properties)
- Certified LUP Policy 4.27 (use of drought resistant landscaping)
- Certified LUP Policy 4.28 (stormwater runoff)
- Certified LUP Policy 4.32 (use of preferred engineering designs)
- Certified LUP Policy 4.38 (aesthetics)
- Certified LUP Policy 4.39 (payment of mitigation fees)
- Certified LUP Policy 4.45 (bluff retention device design)
- Certified LUP Policy 4.49 (findings)
- Certified LUP Policy 4.50 (impact mitigation fees)
- Certified LUP Policy 4.54 (shoreline protection device maintenance)
- Certified LUP Policy 4.55 (coordination among neighbors)
- Certified LUP Policy 4.58 (development on the bluff)

Policy 4.26: *With respect to bluff properties only, the City will require the removal or capping of any permanent irrigation system within 100 feet of the bluff edge in connection with issuance of discretionary permits for new development, redevelopment, or shoreline protection, or bluff erosion, unless the bluff property owner demonstrates to the satisfaction of the Public Works Director, or the CCC if the project is appealed, that such irrigation has no material impact on bluff erosion (e.g., watering hanging plants over hardscape which drains to the street).*

- **Project Compliance with Policy 4.26:** The project has been conditioned to require the removal or capping of any permanent irrigation system within 100 feet of the bluff edge.

Policy 4.27: *Require all bluff property landscaping for new development to consist of native, non-invasive, drought-tolerant, fire-resistant, and salt-tolerant species.*

- **Project Compliance with Policy 4.27:** After the return wall has been constructed, a reinforced soil slope (RSS) would be constructed to repair the mid and upper bluff. The RSS would consist of geotextile grids that would be pinned to the slope with hand driven mechanical anchors and covered with soil and a hydroseed application that would utilize drought resistant, salt tolerant native species. The proposed hydroseed mix (Attachment 4) has been reviewed by the City's third-party landscape architect and have been found to be consistent with this policy.

Policy 4.28: *All storm water drain systems that currently drain or previously drained towards the west over the bluff shall be capped. These systems should be redesigned to drain directly, or through a sump system, and then pumped to the street in compliance with SWP 2007-0001 and consistent with SUSMP requirements. This policy shall be implemented as a*

condition of approval for all discretionary permits issued for bluff properties or within 5 years of adoption of the LCP, whichever is sooner.

- **Project Compliance with Policy 4.28:** The project has been conditioned to require that all storm water drain systems that currently drain towards the west over the bluff be capped.

Policy 4.32: *When bluff retention devices are unavoidable, encourage applicants to pursue preferred bluff retention designs as depicted in Appendix B of the LUP when required to protect an existing principal structure in danger from erosion. All future bluff retention device applications should utilize these designs as the basis of site-specific engineering drawings to ensure consistency with the LUP.*

- **Project Compliance with Policy 4.32:** The project has been designed to be consistent with a mixture of the engineering requirements of Figure 3 and Figure 4 of LUP Appendix B.

Policy 4.38: *Maximize the natural, aesthetic appeal and scenic beauty of the beaches and bluffs by avoiding and minimizing the size of bluff retention devices, preserving the maximum amount of unaltered or natural bluff face, and minimizing encroachment of the bluff retention device on the beach, to the extent feasible, while ensuring that any such bluff retention device accomplishes its intended purpose of protecting existing principal structures in danger from erosion.*

- **Project Compliance with Policy 4.38:** The project has been designed to be the minimum size required to stabilize the bluff and protect the existing bluff top structures (Building 3) and the City infrastructure. An alternatives analysis was prepared for the proposed project and is contained in Attachment 5.

Policy 4.39: *Provide for reasonable and feasible mitigation for the impacts of all bluff retention devices which consists of the payment of Sand Mitigation Fees and Public Recreation Fees to the City or other assessing agency.*

- **Project Compliance with Policy 4.39:** The project has been conditioned to mitigate for all impacts related to sand supply and public recreation through the payment of impact mitigation fees.

Policy 4.45: *The City has adopted preferred bluff retention solutions (see Appendix B) to streamline and expedite the City permit process for bluff retention devices. The preferred bluff retention solutions are designed to meet the following goals and objectives:*

- (1) *Locate bluff retention devices as far landward as feasible;*
- (2) *Minimize alteration of the bluff face;*
- (3) *Minimize visual impacts from public viewing areas; ,*
- (4) *Minimize impacts to adjacent properties including public bluffs and beach area;*
and,
- (5) *Conduct annual visual inspection and maintenance as needed.*

The bluff property owner's licensed Civil or Geotechnical Engineer must examine the device for use in the specific location and take responsibility for the design as the Engineer of Record.

The Bluff Property Owner shall arrange for and pay the costs of:

- (1) The licensed Geotechnical or Civil Engineer;*
- (2) The bluff retention device;*
- (3) A bond to ensure completion of the bluff retention device;*
- (4) Appropriate mitigation; and*
- (5) All necessary repairs, maintenance, and if needed removal.*

- **Project Compliance with Policy 4.45:** The project Applicant has paid for their licensed Geotechnical Engineer and will pay the construction costs for the bluff retention device and will be conditioned to pay the City a bond to ensure completion of the bluff retention device. Sand Supply and Public Recreation Impact Mitigation fees are required to be paid by the Applicant prior to issuance of the construction permit. The Applicant will be responsible for all necessary future repairs and maintenance.

Policy 4.49: *Coastal structures shall be approved by the City only if all the following applicable findings can be made and the stated criteria satisfied. The permit shall be valid until the currently existing structure requiring protection is redeveloped (per definition of Bluff Top Redevelopment in the LUP), is no longer present, or no longer requires a protective device, whichever occurs first and subject to an encroachment/removal agreement approved by the City.*

- (a) Based upon the advice and recommendation of a licensed Geotechnical or Civil Engineer, the City makes the findings set forth below.*
 - (1) A bluff failure is imminent that would threaten a bluff home, city facility, city infrastructure, and/or other principal structure.*
 - (2) The coastal structure is more likely than not to preclude the need for a larger coastal structure or upper bluff retention structure. Taking into consideration any applicable conditions of previous permit approvals for development at the subject site, a determination must be made based on a detailed alternatives analysis that none of the following alternatives to the coastal structure are currently feasible, including:*
 - *A Seacave/Notch Infill;*
 - *A smaller coastal structure; or*
 - *Other remedial measures capable of protecting the bluff home, city facility, non-city-owned utilities, and/or city infrastructure, which might include or other non-beach and bluff face stabilizing measures, taking into account impacts on the near and long term integrity and appearance of the natural bluff face, and contiguous bluff properties;*
 - (3) The bluff property owner did not create the necessity for the coastal structure by unreasonably failing to implement generally accepted erosion and drainage control measures, such as reasonable management of surface drainage, plantings and irrigation, or by otherwise unreasonably acting or failing to act with respect to the bluff property. In determining whether or not the bluff*

property owner's actions were reasonable, the City shall take into account whether or not the bluff property owner acted intentionally, with or without knowledge, and shall consider all other relevant credible scientific evidence, as well as, relevant facts and circumstances.

- (4) *The location, size, design and operational characteristics of the proposed coastal structure will not create a significant adverse effect on adjacent public or private property, natural resources, or public use of, or access to, the beach, beyond the environmental impact typically associated with a similar coastal structure and the coastal structure is the minimum size necessary to protect the principal structure, has been designed to minimize all environmental impacts, and provides mitigation for all coastal and environmental impacts, as provided for in this LCP.*
- (b) *The coastal structure shall meet City Design Standards, which shall include the following criteria to ensure the coastal structure will be:*
- (1) *Constructed to resemble as closely as possible the natural color, texture and form of the adjacent bluffs;*
 - (2) *Landscaped, contoured, maintained and repaired to blend in with the existing environment;*
 - (3) *Designed so that it will serve its primary purpose of protecting the bluff home or other principal structure, provided all other requirements under the implementing ordinances are satisfied, with minimal adverse impacts to the bluff face;*
 - (4) *Reduced in size and scope, to the extent feasible, without adversely impacting the applicant's bluff property and other properties; and*
 - (5) *Placed at the most feasible landward location considering the importance of preserving the maximum amount of natural bluff and ensuring adequate bluff stability to protect the bluff home, City facility, or City infrastructure.*
- (c) *Mitigation for the impacts to shoreline and sand supply, public access and recreation and any other relevant coastal resource impacted by the coastal structure is required and shall be assessed in 20-year increments, starting with the building permit completion certification date. Property owners shall apply for a CDP amendment prior to expiration of each 20-year mitigation period, proposing mitigation for coastal resource impacts associated with retention of the coastal structure beyond the preceding 20-year mitigation period and shall include consideration of alternative feasible measures in which the permittee can modify the coastal structure to lessen the coastal structure's impacts in coastal resources. Monitoring reports to the City and the Coastal Commission shall be required every five years from the date of the CDP issuance until CDP expiration, which evaluate whether or not the coastal structure is still required to protect the existing structure it was designed to protect. The permittee is required to submit a CDP application to remove the authorized coastal structure within six months of a determination that the coastal structure is no longer required to protect the existing structure it was designed to protect.*

- **Project Compliance with Policy 4.49:** An alternatives analysis is included in Attachment 5. Alternatives considered but rejected include: the proposed project, a seawall extension and no project. The City's third-party geotechnical engineer has confirmed that the project complies with, or has satisfied all of the findings required in, this policy (Attachment 6). Imminent bluff failure potential has been confirmed based on the factors of safety as shown in Table 1 shown previously in this report. The project has been designed consistent with the engineering design requirements of Figure 3 and Figure 4, Appendix B of the LUP. Mitigation has been imposed on the project as a condition of approval.

Policy 4.50: *The bluff property owner shall pay for the cost of the coastal structure or Infill and pay a Sand Mitigation Fee and a Public Recreation Fee per LUP Policy 4.39. These mitigation fees are not intended to be duplicative with fees assessed by other agencies. It is anticipated the fees assessed as required by this LCP will be in conjunction with, and not duplicative of, the mitigation fees typically assessed by the CCC and the CSLC for impacts to coastal resources from shoreline protective devices.*

- **Project Compliance with Policy 4.50:** The project will be required to mitigate all sand supply and public recreation impacts through the payment of mitigation fees to the City. The Applicant will also be required to obtain all necessary permits and approvals from the CCC and the CSLC prior to the City issuance of a construction permit.

Policy 4.54: *Any bluff retention device shall be reasonably maintained and repaired by the bluff property owner on an "as needed" basis, at the bluff property owner's expense, in accordance with the implementing ordinances and any permit issued by the City. Any authorized assessing entity in which the project lies shall ensure such payments are reimbursed to the City if the bluff property owner fails to perform such work and the City elects to do so, subject to mandatory reimbursement. However, in all cases, after inspection, it is apparent that repair and maintenance is necessary, including maintenance of the color of the structures to ensure a continued match with the surrounding native bluffs, the bluff property owner or assessing entity shall contact the City or CCC office to determine whether permits are necessary, and, if necessary, shall subsequently apply for a coastal development permit for the required maintenance.*

- **Project Compliance with Policy 4.54:** The project has been conditioned to include a requirement that the proposed project be repaired and maintained as needed for the life of the structure.

Policy 4.55: *To achieve a well maintained, aesthetically pleasing, and safer shoreline, coordination among property owners regarding maintenance and repair of all bluff retention devices is strongly encouraged. This may also result in cost savings through the realization of economies of scale to achieve these goals by coordination through an assessing entity. All bluff retention devices existing as of the date of certification of the LCP, to the extent they do not conform to the requirements of the LCP, shall be deemed non-conforming. A bluff property owner may elect to conform his/her/its bluff property or bluff retention device to the LCP at any time if the City finds that an existing bluff retention device that is required to protect existing principal structures in danger from erosion is structurally unsound, is unsafe,*

or is materially jeopardizing contiguous private or public principal structures for which there is no other adequate and feasible solution, then the City may require reconstruction of the bluff retention device.

- **Project Compliance with Policy 4.55:** The subject CUP application was collectively submitted by the Las Brisas Condominium Homeowners Association.

Policy 4.58: *Development on the bluffs, including the construction of a bluff retention device, shall include measures to ensure that:*

- *No stockpiling of dirt or construction materials shall occur on the beach;*
 - *All grading shall be properly covered and sandbags and/or ditches shall be used to prevent runoff and siltation;*
 - *Measures to control erosion shall be implemented at the end of each day's work;*
 - *No machinery shall be allowed in the intertidal zone at any time to the extent feasible;*
 - *All construction debris shall be properly collected and removed from the beach. Shotcrete/concrete shall be contained through the use of tarps or similar barriers that completely enclose the application area and that prevent shotcrete/concrete contact with beach sands and/or coastal waters.*
- **Project Compliance with Policy 4.58:** Compliance with the requirements of this policy have been included as engineering conditions of approval.

Resolution No. 2022-013 (Attachment 1) contains citations to relevant policies of the City's LUP as conditions of approval.

Sand Mitigation Fee and Public Recreation Impact Mitigation Fee Deposit

As a condition of their 2005 Coastal Development Permit (CDP) to construct the existing seawall below the Las Brisas Condominiums, the Applicant was required to pay a fee of \$309,000 for, *"the loss of sandy beach area and thus the loss of public recreational impacts"* as well as *"\$22,977.36 for the loss of sand."* The proposed lateral return wall would be constructed to retain the beach sands behind the existing seawall for which mitigation fees were already paid, therefore, no additional mitigation fees are required with this permit.

Compliance with Solana Beach Certified LUP Policies

Staff has evaluated the CUP application taking into account the following factors: (1) the relevant policies of the City's Certified LUP; (2) the conclusions drawn by the (a) City of Solana Beach's independent third-party geotechnical consultant CTE, INC. regarding the need for the project and the appropriateness of the proposed bluff stabilization devices and (b) the City of Solana Beach City Engineer conditions of approval; and (3) the Applicant's geotechnical reports and supplemental alternatives analysis (Attachments 7, 8, and 9).

After evaluating the Coastal Bluff Evaluation and Project Recommendations from TerraCosta Consulting Group, The Bluff Stabilization Engineering Design Report from GeoStabilization International and the Geotechnical Update and Response to comments from GeoSoils, Inc. provided by the Applicant and included in Attachments 7, 8, and 9, and the third-party review

findings provided by the City's geotechnical engineering consultant, CTE, Inc., and the City Engineer, Staff concurs that the proposed project has met the standard of imminent danger. Without the proposed project to stabilize the bluffs, the prospect of bluff failure could threaten the condominium building 3 and the pedestrian and public agency vehicular access is reasonably foreseeable within the next 12 months according to the factor of safety analysis.

Based on the foregoing information, City Staff finds that the proposed project could be found consistent with applicable LUP policies previously cited.

In addition to the required LUP findings, compliance with the Solana Beach Municipal Code is required to support issuance of a Conditional Use Permit.

Compliance with Solana Beach Municipal Code (SBMC) Findings 17.68.010 (F)

- a. That the proposed use is in accord with the general plan, the general intent of this title, and the purposes of the zone in which the site is located.
- b. That the proposed use, together with the conditions applicable thereto, will not be detrimental to the public health, safety, or welfare, or materially injurious to properties or improvements in the vicinity.
- c. That the proposed use complies with each of the applicable provisions of the zoning ordinance, unless a variance is granted pursuant to SBMC 17.68.020.

The proposed project is consistent with required finding (a), whereby shoreline protective devices are a structure/use allowed in the City to protect bluff top principal structures in danger of erosion.

The proposed project is consistent with the required finding (b) whereby the proposed project is needed to address an emergency condition whereby bluff failure has been confirmed to be imminent by Construction Testing and Engineering, Inc. (CTE, Inc. who is one of the City's on call third-party Geotechnical Engineering Firms).

The proposed project is consistent with the required finding (c) whereby the proposed project is consistent with the zoning ordinance which allows shoreline protection.

CEQA COMPLIANCE STATEMENT:

The proposed project qualifies as an emergency repair pursuant to the California Environmental Quality Act (CEQA) Public Resources Code §§ 21060.3, as evidenced by a licensed geotechnical engineer. Thus, this project is exempt from CEQA per 2022 State CEQA Guidelines §15269(b)(c).

FISCAL IMPACT: N/A

WORK PLAN: N/A

OPTIONS:

- Approve the proposed project and adopt Resolution 2022-013.
- Deny the proposed project.
- Provide alternative direction.

DEPARTMENT RECOMMENDATION:

Staff recommends that the City Council:

1. Conduct the Public Hearing: Open the public hearing, Report Council disclosures, receive public testimony, and close the public hearing.
2. Find the Proposed Project exempt from the requirements of CEQA pursuant to 2022 State California CEQA Guidelines §15269 as emergency conditions exist onsite.
3. Adopt Resolution 2022-013 conditionally approving a Conditional Use Permit Modification to construct a return wall that would consist of a drilled pier/caisson design with structural concrete between piers, extend from the top of the southern terminus of the existing seawall to the top of the bluff, and would be covered with hand sculpted, colored shotcrete to match the adjacent natural bluff at 135 S. Sierra Avenue, Solana Beach.

CITY MANAGER'S RECOMMENDATION:

Approve Department Recommendation.



Gregory Wade, City Manager

Attachments:

1. Resolution 2022-013
2. Proposed Plans
3. LUP Appendix B Figures 3 and 5
4. Proposed Hydroseed Mix
5. Alternatives Analysis
6. CTE, INC. Third-Party Review Letters 1 and 2
7. Coastal Bluff Evaluation and Project Recommendations, TerraCosta Consulting Group
8. Las Brisas Bluff Stabilization Engineering Design Manual, GeoStabilization International
9. Geotechnical Update and Response to Third-Party Geotechnical Review, GeoSoils, Inc.

RESOLUTION 2022-013

A RESOLUTION OF THE CITY COUNCIL OF THE CITY OF SOLANA BEACH, CALIFORNIA, APPROVING A CONDITIONAL USE PERMIT MODIFICATION FOR THE CONSTRUCTION OF A MICROPILE RETURN WALL, MID-AND UPPER-BLUFF RESTORATION AND LANDSCAPING BELOW 135 S. SIERRA AVENUE IN SOLANA BEACH.

**APPLICANTS: Las Brisas Homeowners Association
CASE NO.: CUP20-004**

WHEREAS, the Applicant, the Las Brisas Homeowners Association (hereinafter referred to as "Applicant") has submitted an application for a Conditional Use Permit (CUP) pursuant to Title 17 (Zoning) of the Solana Beach Municipal Code (SBMC); and

WHEREAS, the City Council adopted the Amended Local Coastal Program (LCP) Land Use Plan (LUP) in June 2014 with policies allowing for the construction of shoreline protective devices in the City as allowed by California Coastal Act Section 30235; and

WHEREAS, a Coastal Bluff Evaluation and Basis of Design Report prepared by TerraCosta Consulting Group, Project Plans and Structural Calculations prepared by Soils Engineering Construction and supplemental technical materials prepared by GeoSoils, Inc. has been reviewed and confirmed by Geopacifica Geotechnical Consultants (Geopacifica), the City's third party independent geotechnical consultant, in a letter dated March 14, 2018 indicating the proposed project is required and has been designed consistent with all City requirements; and

WHEREAS, the existing static factors of safety onsite below the pedestrian/vehicular access area and Building 3 of Las Brisas are currently 1.021 and 1.19 respectively; and

WHEREAS, a factor of safety equal to or less than 1.0 represents a slope that is structurally failing whereby the generally accepted factor of safety calculation for purposes of determining bluff stability and the potential for imminent failure is a factor of safety of 1.2 or less the bluff top principal structure (Building 3) and the public agency vehicular access and pedestrian access are considered in "imminent danger" from potential bluff collapse and/or failure; and

WHEREAS, at the duly noticed public hearing held on February 9, 2022, the City Council received and considered evidence concerning the proposed application as received; and

WHEREAS, the public hearing was conducted pursuant to the provisions of Solana Beach Municipal Code Section 17.72.030; and

WHEREAS, the City Council of the City of Solana Beach found the proposed project exempt from the California Environmental Quality Act pursuant to State CEQA Guidelines § 15269 as a documented geologic emergency exists onsite; and

WHEREAS, the proposed project will be designed to be located as far landward as possible, contoured, color matched and sculpted to match the surrounding bluff and will be maintained over the life of the structure consistent with the engineering design requirements depicted in Solana Beach Certified LCP LUP Appendix B, Figure 3; and

WHEREAS, this decision is based upon the evidence contained in the subject application, testimony of Geopacifica, evidence presented at the hearing and any information the City Council gathered by viewing the site and the area as disclosed at the hearing.

NOW THEREFORE, the City Council of the City of Solana Beach, California, does resolve as follows:

1. That the foregoing recitations are true and correct.
2. That the project is categorically exempt from the requirements of CEQA pursuant to 2022 State California CEQA Guidelines 15269.
3. That the request for a Conditional Use Permit Modification to construct a return wall that would consist of a drilled pier/caisson design with structural concrete between piers that would extend from the top of the southern terminus of the existing seawall to the top of the bluff, would be covered with hand sculpted, colored shotcrete to match the adjacent natural bluff, would include and mid and upper bluff reconstruction and landscaping at 135 S. Sierra Avenue is conditionally approved based upon the following Findings and subject to the following Conditions:

4. FINDINGS

- A. Compliance with Solana Beach Certified LCP LUP Policy Requirements: A consistency finding with the City's Local Coastal Program (LCP) Land Use Plan (LUP) is required for the proposed project. The City's LUP policies were certified to be consistent with Coastal Act Section 30235 which states: Revetments, breakwaters, groins, harbor channels, seawalls, cliff retaining walls, and other such construction that alters natural shoreline processes shall be permitted when required to serve coastal-dependent uses or to protect existing structures or public beaches in danger from erosion, and when designed to eliminate or mitigate adverse impacts on local shoreline sand supply.

Applicable City policies from the City's Certified LUP (as amended) are listed below. The project complies or has been conditioned to comply with all applicable and relevant City LUP policies including:

Certified LUP Policy 4.26 (irrigation controls for bluff properties);

Certified LUP Policy 4.27 (use of drought resistant landscaping);
Certified LUP Policy 4.28 (stormwater runoff);
Certified LUP Policy 4.32 (use of preferred engineering designs);
Certified LUP Policy 4.38 (aesthetics);
Certified LUP Policy 4.39 (payment of mitigation fees);
Certified LUP Policy 4.45 (bluff retention device design);
Certified LUP Policy 4.49 (findings);
Certified LUP Policy 4.50 (impact mitigation fees);
Certified LUP Policy 4.54 (shoreline protection device maintenance);
Certified LUP Policy 4.55 (coordination among neighbors); and
Certified LUP Policy 4.58 (development on the bluff).

B. Compliance with Solana Beach Municipal Code (SBMC) Findings 17.68.010:

- a. *That the proposed use is in accord with the general plan, the general intent of this title, and the purposes of the zone in which the site is located.*

The proposed project is consistent with the required finding, whereby shoreline protective devices are a structure/use allowed in the City to protect bluff top principal structures in danger of erosion.

- b. *That the proposed use, together with the conditions applicable thereto, will not be detrimental to the public health, safety, or welfare, or materially injurious to properties or improvements in the vicinity.*

The proposed project is consistent with the required finding, whereby the proposed project is needed to address an emergency condition whereby bluff failure has been confirmed to be imminent by CTE Inc. (Construction Testing and Engineering, Inc. one of the City's third party geotechnical Engineering firms).

- c. *That the proposed use complies with each of the applicable provisions of the zoning ordinance, unless a variance is granted pursuant to SBMC 17.68.020.*

The proposed project is consistent with the required finding, whereby the proposed project is consistent with the zoning ordinance which allows shoreline protection.

5. CONDITIONS

Prior to use or development of the property in reliance on this permit, the Applicant shall provide for and adhere to the following conditions:

A. Community Development Department Conditions:

- I. Building Permit plans must be in substantial conformance with the plans presented to the City Council on February 9, 2022 and located in the project file with a submittal date of December 21, 2020.
- II. The Applicant shall obtain required California Coastal Commission (CCC) approval of a Coastal Development Permit, waiver or exemption as determined necessary by the CCC, prior to the issuance of a grading or building permit.
- III. The repairs will be constructed and maintained to incorporate an earth-like appearance which will resemble, as closely as possible, the color and texture of the surrounding bluffs.
- IV. The Applicant shall remove or cap any permanent irrigation system within 100 feet of the bluff edge in connection with issuance of discretionary permits for new development, redevelopment, or shoreline protection, or bluff erosion, unless the bluff property owner demonstrates to the satisfaction of the Public Works Director, or the CCC if the project is appealed, that such irrigation has no material impact on bluff erosion (e.g., watering hanging plants over hardscape which drains to the street).
- V. All storm water drain systems that currently drain or previously drained towards the west over the bluff shall be capped. These systems should be redesigned to drain directly, or through a sump system, and then pumped to the street in compliance with the current Regional Water Quality Control Board (RWQCB) Standard Urban Storm Water Mitigation Plan (SUSMP) requirements.
- VI. Any bluff retention device shall be reasonably maintained and repaired by the bluff property owner on an "as needed" basis, at the bluff property owner's expense, in accordance with the implementing ordinances and any permit issued by the City. Any authorized assessing entity in which the project lies shall ensure such payments are reimbursed to the City if the bluff property owner fails to perform such work and the City elects to do so, subject to mandatory reimbursement. However, in all cases, after inspection, it is apparent that repair and maintenance is necessary, including maintenance of the color of the structures to ensure a continued match with the surrounding native bluffs, the bluff property owner or assessing entity shall contact the City or CCC office to determine whether permits are necessary and, if necessary, shall subsequently apply for a coastal development permit for the required maintenance.
- VII. No stockpiling of dirt or construction materials shall occur on the

beach.

- VIII. All grading shall be properly covered and sandbags and/or ditches shall be used to prevent runoff and siltation.
- IX. Measures to control erosion shall be implemented at the end of each day's work.
- X. No machinery shall be allowed in the intertidal zone at any time to the extent feasible.
- XI. All construction debris shall be properly collected and removed from the beach. Shotcrete/concrete shall be contained through the use of tarps or similar barriers that completely enclose the application area and that prevent shotcrete/concrete contact with beach sands and/or coastal waters.
- XII. Temporary irrigation shall be periodically inspected every six months following planting to ensure planting success and to verify that irrigation is still required. At six month intervals, a report prepared by a licensed landscape architect detailing the status of the vegetation, an assessment on the condition of the temporary irrigation system, and provides supporting information on whether the temporary irrigation is still needed shall be provided to the City. The City will issue a determination on the status of the temporary irrigation system upon reviewing the report. The City can require the removal of the temporary irrigation system at anytime. The temporary irrigation system may remain active and in place up to a maximum of 24 months at the approval of the City and must be removed once the plants have become established.
- XIII. All required plantings will be maintained in good growing condition throughout the life of the project and, whenever necessary, shall be replaced with new plant materials to ensure continued compliance with the landscape plan.
- XIV. The temporary irrigation system shall include redundant valve control/shut off valves to prevent any irrigation system leaks/failures.

B. Fire Department Conditions:

- I. OBSTRUCTION OF ROADWAYS DURING CONSTRUCTION: All roadways shall be a minimum of 20 feet in width during construction and maintained free and clear, including the parking of vehicles, in accordance with the California Fire Code and the Solana Beach Fire Department.

- C. Engineering Department Conditions: Prior to obtaining any building or grading permits pursuant to this project, the Applicants shall:
- I. Prior to obtaining any building or grading permits pursuant to this colored concrete seacave infill maintenance project, the Applicant shall:
 - a. Prepare, execute and record a declaration of restrictions on real property approved by the City Attorney whereby the applicant or the applicant's successors in interest to the property will construct and maintain the shoreline defense structure in accordance with Conditions of this approval.
 - b. The declaration of restrictions shall include an agreement by the Applicant to defend, indemnify, and hold harmless the City, its agents, officers, and employees from any and all claims, actions, proceedings, damages, judgments, or costs, including attorney's fees, against the City or its agents, officers, or employees, relating to any claim for damages from any injury to person or property caused by the shoreline defense structure or by its failure.
 - c. Said declaration of restrictions shall be acknowledged and recorded in the office of the County Recorder.
 - d. Per Policy 4.49 of the certified LUP, an Encroachment Maintenance and Removal Agreement is required when the proposed Bluff Retention Device (BRD) is located in whole or in part on public land. In order to determine if an Encroachment Removal Agreement is required for this project, the applicant shall submit an engineering plan clearly showing the property lines, existing topography and the location of the proposed BRD.
 - e. Obtain required California Coastal Commission Permits prior to the issuance of any structure and grading permits or present evidence that an emergency waiver has been granted.
 - f. Obtain any other permits or emergency waivers, which may be required from State and Federal agencies including the State Lands Commission and the U.S. Army Corps of Engineers.
 - g. The project shall be designed and shall provide appropriate data to confirm the submitted design to the satisfaction of the City Engineer. This shall include, but is not limited to, a geotechnical report.

- h. The property owners shall post securities to guarantee proper care and use of the Fletcher Cove ramp. No construction materials to be off-loaded on the ramp, at the end of the ramp or any public property including streets and Fletcher Cove Park. No washing of equipment shall occur unless a containment system is properly utilized.
- i. For all projects on which equipment is driven on the Fletcher Cove Beach Access Ramp, the access ramp and adjacent parking lot must be swept daily to remove sand that has been tracked onto the ramp and parking lot. At least once a week, the access ramp and parking lot must be swept with a street sweeper that is capable of cleaning the streets and parking lots of paper, glass, dirt, silt, sand, rocks, litter and miscellaneous debris. The street sweeper shall be equipped with dual gutter brooms, and vacuum equipment may be used. If any sand is tracked outside the parking lot, these areas (including city streets) must also be cleaned weekly with a street sweeper.
- j. The property owners shall pay all inspection and plan check fees as required by the City.
- k. Plans and specifications for the project shall be approved by the City Engineer in addition to approvals from the Director of Planning as may be required, and shall substantially conform to the plans submitted by the Applicant. All bluff stabilization devices shall produce a natural appearing bluff to the satisfaction of the City Engineer and the Community development director. Project implementation shall provide a final product mimicking a naturally appearing bluff in terms of colors, textures, forms and angles.
- l. A grading/drainage plan shall be prepared by a registered civil engineer in accordance with the current Grading Ordinance and be submitted to the City Engineer for approval and permit issuance.
- m. Plans and specifications for the project shall be approved by the Planning Department prior to submittal to the Engineering Department.
- n. The Applicant shall post with the City a Performance Bond equal to the full amount of the work to be completed to guarantee that once started, construction will be completed per approved plans.
- o. The Applicant shall submit a Certificate of Insurance naming the City of Solana Beach as an additional insured in the amount of

\$2,000,000 on a policy of general liability insurance issued by an insurance company licensed to do business in California, and meeting the requirements established by City Council resolution for insurance companies doing business with the City, covering injuries to persons and property during the construction period.

- p. The Applicant shall obtain a Special Use (Marine Safety) Permit specifying the conditions governing use of vehicles, use of the boat ramp, and entry upon and use of areas of the public beach for construction equipment and vehicles. Evidence of permit issuance shall be submitted to the City Engineer before issuance of the permit for the project.
- q. The Applicant shall have on file evidence from the Captain of Marine Safety and City Engineer, City of Solana Beach, that arrangements have been made to satisfy the following criteria:
 - i. Prior to usage of the Solana Beach Fletcher Cove ramp or parking lot, a cash deposit, bond or other secured agreement to cover the following impact charges shall be deposited:
 - A six dollars (\$6.00) per round trip vehicle charge for all construction related vehicles using the ramp.
 - A three dollars (\$3.00) per ton fee, or less if approved by the City Council, based on the estimated weight of the vehicle and load for all vehicles in excess of $\frac{3}{4}$ ton capacity, excluding any vehicles solely transporting beach grade replenishment sand.
 - A twenty-nine dollars (\$29) per day charge for the first 30 days escalating to fifty-five dollars (\$55) per day for the 31st and subsequent days charge shall be collected to encourage a timely completion of all projects, unless otherwise modified for good cause by the City Council or City Manager.
 - Any damage caused to the Solana Beach Fletcher Cove ramp and parking lot.
 - ii. At least one City of Solana Beach Lifeguard shall be contracted, at the Applicant's expense, through the Captain of Marine Safety, to monitor all activities in order to insure full compliance with the conditions of this permit. The lifeguard(s) shall be on duty at all times when any construction activity takes place. Additional lifeguards may

be required at the discretion of the Captain of Marine Safety. In addition to the lifeguard staffing cost, the Applicant shall also pay a Marine Safety equipment use fee of four-dollar and sixty-four cents (\$4.64) per hour, based on the number of the number of hours the lifeguards are contracted for the project.

- iii. If construction access is from Fletcher Cove Park, precautions shall be taken to avoid damage to the beach access ramp during construction and repairs. If damage to the ramp occurs, it shall be repaired to a condition equivalent to the condition at the start of construction activity to the satisfaction of the City of Solana Beach City Engineer. All City owned work areas including Fletcher Cove Park and access ramp shall be videotaped prior to the commencement of the project. The videotape shall establish the "as-is" condition. In any areas missed by the videotape, the City Engineer will determine "as-is" condition.

If access is from the State Park at the north end of Solana Beach, precautions shall be taken to avoid damage to the hard layer of fossiliferous sandstone that forms the beach surface at the north end of the coastal bluffs. Such access may necessitate State approval. Proof of such access shall be provided to the City Engineer before construction begins.

- r. Beach quality sand from the excavation for the proposed project shall be deposited and spread on the beach in front of this site unless unique and/or inappropriate conditions are encountered. The Applicant should reference this condition to other permitting agencies.
- s. An encroachment permit from the Engineering Department is required if a crane, construction materials, etc. are envisioned to be stationed in the public right of way. The City does not guarantee that an encroachment permit will be approved.
- t. Any grout mixture used on the project that may be visible from the beach or surrounding areas shall be of similar color as the surrounding natural bluffs. Color samples shall be submitted and approved by the City prior to placing the grout.
- u. The structure and any exposed construction shall mimic the natural contours, color and texture to the maximum extent practicable, as determined by the City Engineer and Community Development Director.

- v. A carved, colored and textured facade on the face of the structure matching the adjacent bluff areas shall be constructed. The façade shall match the contours, both vertically and horizontally, and the texture of the adjacent natural bluffs to the maximum extent feasible. Coastal bluff colored grouting shall be used and shall be submitted to the City Engineer before approval of the plans. A test prism shall be cast and delivered to a testing lab during construction.
 - w. A qualified, licensed and insured contractor shall perform all required work as outlined by certified/registered engineering geologist or Registered Civil Engineer on the construction plans. Special and general notes on said plans shall be followed to the satisfaction of the City Engineer or his designee.
 - x. Lateral pedestrian and Marine Safety vehicular access through the construction area, shall be provided past the site at all times, subject to high tides and safety issues. A 30-foot-wide safety/construction work zone shall be provided during work hours to separate the work zone from the open public beach.
 - y. No construction activities may occur on the beach during the busier recreational season, which is defined as the period between Memorial Day and Labor Day of any year. The contractor shall obtain approval from the City of Solana Beach Engineering and Marine Safety Departments regarding the use and timing of the Fletcher Cove parking lot and beach access ramp for all construction related access, staging and parking issues if such use becomes required.
- II. Prior to Final Inspection of the project, the Applicant shall:
- a. Submit certification to the City Engineer from the Geotechnical Engineer and the Civil Engineer of Record for the project that they have inspected the project and certify that it was constructed per the approved plan, specifying the date of the plan.
 - b. The applicant and/or contractor shall repair any damage caused to the Solana Beach property and facilities, including but not limited to, Fletcher Cove ramp and parking lot to the satisfaction of the City Engineer.
- III. The Applicant shall provide for and adhere to the following Conditions:

- a. All development on the site shall substantially conform to the final Conditional Use Permit Plan approved by the City Council.
 - b. The property owner shall be responsible to immediately remove, in perpetuity, any graffiti or other markings should they appear on the project exterior face. If erosion exposes the steel rebar, the Applicant or their successor in interest shall arrange to apply a sculptor-coat of concrete over the exposed steel to match the natural bluff. The property owner shall be responsible for the removal of the structure or any portion thereof.
 - c. If requested by the City Manager or his designee, the property owner or their successor in interest shall install and maintain signage about unstable bluffs fronting their property.
 - d. The applicant shall provide "As-Built" plans and all certifications required to the City, before the City will release the performance bond as indicated in condition 1.XII.
 - e. Pursuant to SBMC Section 7.34.100, Construction hours are limited to 7:00 a.m. to 7:00 p.m., Monday through Friday, and 8:00 a.m. to 7:00 p.m. on Saturday. No work is allowed on Sunday or holidays unless specifically approved pursuant to SBMC Section 7.34.100.B. Engines shall not be started, no construction-related materials shall be moved, or any other construction-related activities occur outside these hours. Work is not permitted on the beach on Saturdays without the written approval of the City Manager.
6. ENFORCEMENT: Pursuant to SBMC 17.72.120(B) failure to satisfy any and all of the above-mentioned conditions of approval is subject to the imposition of penalties as set forth in SBMC Chapters 1.1.6 and 1.18 in addition to any applicable revocation proceedings.
7. EXPIRATION: The Conditional Use Permit for the project will expire 24 months from the date of project approval unless the Applicant has obtained building/grading permits and commenced construction prior to that date, and diligently pursued construction to completion. An extension of the application may be granted by the City Council.
8. INDEMNIFICATION AGREEMENT: The Applicant shall defend, indemnify, and hold harmless the City, its agents, officers, and employees from any and all claims, actions, proceedings, damages, judgments, or costs, including attorney's fees, against the City or its agents, officers, or employees, relating to the issuance of this permit including, but not limited to, any action to attack, set aside, void, challenge, or annul this development approval and any environmental document or decision. The City will promptly notify Applicant of

any claim, action, or proceeding. The City may elect to conduct its own defense, participate in its own defense, or obtain independent legal counsel in defense of any claim related to this indemnification. In the event of such election, Applicant shall pay all of the costs related thereto, including without limitation reasonable attorney's fees and costs. In the event of a disagreement between the City and Applicant regarding litigation issues, the City shall have the authority to control the litigation and make litigation related decisions, including, but not limited to, settlement or other disposition of the matter. However, the Applicant shall not be required to pay or perform any settlement unless such settlement is approved by Applicant.

9. NOTICE TO APPLICANT: Pursuant to Government Code Section 66020, you are hereby notified that the 90-day period to protest the imposition of the fees, dedications, reservations or other exactions described in this resolution commences on the effective date of this resolution. To protest the imposition of any fee, dedications, reservations or other exactions described in this resolution you must comply with the provisions of Government Code Section 66020. Generally the resolution is effective upon expiration of the tenth day following the date of adoption of this resolution, unless the resolution is appealed or called for review as provided in the Solana Beach Zoning Ordinance.

PASSED AND ADOPTED at a regular meeting of the City Council of the City of Solana Beach, California, held on the 9th day of February 2022, by the following vote:

AYES: Councilmembers –
NOES: Councilmembers –
ABSENT: Councilmembers –
ABSTAIN: Councilmembers –

Lesa Heebner, Mayor

APPROVED AS TO FORM:

ATTEST:

JOHANNA N. CANLAS, City Attorney

ANGELA IVEY, City Clerk

BLUFF STABILIZATION PLANS

LAS BRISAS CONDOMINIUMS

CITY OF SOLANA BEACH, CA
LAS BRISAS HOA



VICINITY MAP

(NOT TO SCALE)

SHEET INDEX

NO.	DESCRIPTION
C-01	COVER SHEET
C-02	GENERAL NOTES
C-03	GENERAL NOTES (CONT.)
C-04	EXISTING SITE & ACCESS PLAN
C-05	PROJECT SITE PLAN
C-06	SECTION VIEW - CUTOFF WALL
C-07	CUTOFF WALL DETAILS
C-08	MICROPILE ANCHOR DETAILS
C-09	MICROPILE CAP DETAILS
C-10	SECTION VIEW - RSS SYSTEM
C-11	PHASE II MITIGATION SECTION
C-12	MICROPILE TESTING DETAILS
C-13	DRILL LOGS

SHEET REVISIONS

DATE	DESCRIPTION	NO.
09/01/21	ISSUED FOR REVIEW	IF R
10/20/21	ISSUED FOR PERMIT	IF P

PROJECT NAME:

LAS BRISAS CONDOMINIUMS

SHEET TITLE:

COVER SHEET

DRAWN BY:

MAC

CHECKED BY:

JDR

DATE:

10/20/21

PROJECT NUMBER:

210487CA01

SHEET

C-01



Phone: 855.579.0536 | Fax: 970.246.7737
www.geostabilization.com



THIS DRAWING IS FURNISHED SOLELY FOR THE USE OF OR IN CONNECTION WITH THIS PROJECT AND THE PROPRIETARY INFORMATION SHOWN HEREON IS NOT TO BE TRANSMITTED TO ANY OTHER ORGANIZATION WITHOUT SPECIFIC AUTHORIZATION BY GEOSTABILIZATION INTERNATIONAL, LLC. THE DESIGN IS ONLY VALID IF CONSTRUCTED AND SUPERVISED BY GSI OR ITS AUTHORIZED SUBCONTRACTOR.

ATTACHMENT 2

GENERAL NOTES:

- GSI WILL BE THE LEAD FOR JOB SITE CONDITIONS AND SAFETY DURING CONSTRUCTION HOURS. THE JOB SITE WILL BE KEPT REASONABLY SECURE TO DETER UNAUTHORIZED ENTRY OR TAMPERING. HOWEVER, THOSE WHO ENTER THE CONSTRUCTION ZONE WITHOUT ENTRY WILL BE CONSIDERED TO BE TRESPASSING.
- GSI WILL USE UTILITY ONE CALL SERVICES, REQUEST UTILITY MAPS, AND REQUEST POTHOLING AS NEEDED TO LOCATE AND MARK KNOWN UTILITIES.
 - DIG ALERT: DIAL 811, OR DIGALERT.ORG
 - CITY OF SOLANA BEACH PUBLIC WORKS: 858-720-2470
- AT THE END OF EACH WORK DAY GSI WILL LEAVE THE WORK AREA FREE OF HAZARDS, AND PROVIDE TEMPORARY SIGNS, WARNING DEVICES, AND/OR BARRICADES, AS NEEDED.
- GSI WILL KEEP RECORDS OF THE DRILLING CONDITIONS, GROUT MIX SPECIFIC GRAVITY AND OTHER NOTES ON THESE PLANS AS NEEDED TO PROVIDE AS-BUILT INFORMATION TO THE OWNER AFTER PROJECT COMPLETION.
- GSI UNDERSTANDS THE WORKING HOURS FOR THIS SITE TO BE 7:00 A.M. AND 7 P.M. EACH DAY, MONDAY THROUGH FRIDAY.
- GSI WILL NOTIFY THE CITY OF SOLANA BEACH AT (858) 720-2470, AT LEAST 24 HOURS BEFORE THE FIRST DAY OR THE PROJECT.

STANDARD REQUIREMENTS:

GSI WILL PERFORM THE WORK IN GENERAL ACCORDANCE WITH THE LATEST EDITION AND SUPPLEMENTS OF THE "STANDARD SPECIFICATIONS FOR PUBLIC WORKS CONSTRUCTION," SAN DIEGO REGIONAL STANDARD DRAWINGS AND CITY OF SOLANA BEACH ENGINEERING CONSTRUCTION STANDARDS.

ASSESSOR PARCEL NUMBERS	ADDRESSES
298-010-54-0001 THROUGH -36	135 S SIERRA AVE

EROSION CONTROL NOTES:

- GSI WILL PLACE SILT FENCE AT THE TOE OF THE SLOPE (TOP OF THE SEA WALL) TO LIMIT ERODED SOILS FROM REACHING THE PUBLIC BEACH.
- GSI WILL USE DIKES, BERMS OR TRENCHES TO LIMIT STORMWATER WATER FLOWING OVER CRESTS OF THE SLOPE.
- GSI WILL USE WATER AS NEEDED TO MINIMIZE AIR BORNE DUST ON THE SITE.

HOUSE KEEPING:

- THE SITE WILL BE ORGANIZED AND CLEAR OF ANY TRASH OR DEBRIS. ALL TRASH WILL BE PLACED IN A PROPER CONTAINER AND REMOVED AT THE END OF EACH WORK DAY.

SAFETY:

- ALL SAFETY PLANS FOR LIFTING, HEARING, DUST CONTROL, PPE ETC. WILL BE IN PLACE AND FOLLOWED ACCORDINGLY. PPE INCLUDES SAFETY VEST, STEEL TOED SHOES, HARD HAT, SAFETY GLASSES, RESPIRATOR DURING DUST PRODUCING ACTIVITIES, AND GLOVES.
- GSI WILL GENERATE A SITE SPECIFIC HEALTH AND SAFETY PLAN THAT MUST BE REVIEWED AND SIGNED BY ALL GSI EMPLOYEES, SUBCONTRACTORS, AND VISITORS TO THE SITE.
- GSI WILL LEAD A DAILY TAILGATE MEETING TO REVIEW JOB HAZARD ANALYSIS "JHA" FOR EACH OF THE DAYS ANTICIPATED TASKS.

EMPLOYEE CERTIFICATIONS:

- ACI SHOTCRETE NOZZLEMEN CERTIFICATION
- 10-HOUR OCCUPATIONAL SAFETY AND HEALTH TRAINING COURSE IN CONSTRUCTION SAFETY & HEALTH
- AMERICAN RED CROSS STANDARD FIRST AID TRAINING

ANTICIPATED CONSTRUCTION SEQUENCE/WORK SCHEDULE:

1. DELINEATE LIMITS OF STABILIZATION. NOTIFY LOCAL UTILITIES PROVIDERS TO LOCATE AND MARK POTENTIAL UNDERGROUND FACILITIES. DAYLIGHTING OF UTILITIES IN POTENTIAL CONFLICT, AS NECESSARY (BY OTHERS).
2. PREPARE THE WORK AREA FOR MICROPILE INSTALLATION AND CUTOFF WALL CONSTRUCTION:
 - 2.1. INSTALL EROSION CONTROL FENCE AT THE TOP OF THE EXISTING SEAWALL TO LIMIT SOIL EROSION DURING CONSTRUCTION.
 - 2.2. MINOR RE-SHAPING OF EXISTING SCARP AND SURROUNDING GRADES MAY BE NEEDED TO FACILITATE CONSTRUCTION OF THE MICROPILE CUTOFF WALL.
 - 2.3. MARK THE LOCATIONS OF THE PROPOSED STABILIZATION ELEMENTS WITH SURVEY MARKING PAINT.
3. INSTALLATION OF MICROPILE ELEMENTS. EACH ELEMENT WILL BE GROUTED DURING DRILLING UNLESS DIRECTED OTHERWISE BY GSI ENGINEER.
4. CONSTRUCT THE CUTOFF WALL:
 - 4.1. PLACE REINFORCING STEEL AND DRAIN STRIPS PER THESE DRAWINGS.
 - 4.2. USE WOOD OR SIMILAR FORMWORK ON THE NORTH SIDE OF THE CUTOFF WALL TO FACILITATE SHOTCRETE PLACEMENT.
 - 4.3. PLACE SHOTCRETE FROM THE BOTTOM UP TO THE REQUIRED THICKNESS DETAILED IN THESE PLANS.
5. PREPARE AREA NORTH OF THE CUTOFF WALL FOR REINFORCED SOIL SLOPE SYSTEM INSTALLATION. MINOR GRUBBING AND GRADING MAY BE NECESSARY.
6. INSTALL REINFORCED SOIL SLOPE SYSTEM IN LIFTS AS DETAILED IN THESE DRAWINGS AND PER THE MANUFACTURER INSTALLATION PROCEDURES.
7. SITE CLEANUP AND DEMOBILIZATION FROM SITE.
 - 7.1. CONCRETE, GROUT, AND OTHER CONSTRUCTION DEBRIS WILL BE REMOVED PERIODICALLY THROUGHOUT THE WORK.
 - 7.2. FINAL CLEANUP OF THE SITE TO INCLUDE REASONABLE HAND CLEANING METHODS LIKE SWEEPING, SPRAYING WITH WATER AND REMOVAL OF TRASH AND DEBRIS. MAJOR LANDSCAPING SHOULD NOT BE NEEDED IF PROPER ACCESS IS GRANTED TO GSI THROUGHOUT THE PROJECT.

SIZE AND TYPE OF STABILIZATION ELEMENTS:

- THE MICROPILE ELEMENTS SHALL CONSIST OF 51mm NOMINAL DIAMETER, SELF-DRILLING HOLLOW BAR. SACRIFICIAL DRILL BITS WILL BE ATTACHED TO THE STABILIZATION ELEMENT PRIOR TO INSTALLATION.
- SACRIFICIAL DRILL BITS ARE NOT PERMANENTLY INCORPORATED INTO THE PROJECT AND MAY BE REMOVED AFTER DRILLING OR LEFT AT THE PROJECT FOR THE CONTRACTOR'S CONVENIENCE. SACRIFICIAL DRILL BITS ARE NOT END PRODUCTS. SACRIFICIAL DRILL BITS ARE NOT PRODUCED IN THE UNITED STATES.
- GSI ENGINEER MAY ELECT TO MODIFY THE TYPE OF STABILIZATION ELEMENT, LENGTH OR INSTALLATION METHOD, DEPENDING ON ACTUAL DRILLING CONDITIONS.

FACING AND DRAINAGE SYSTEM:

- DRAIN STRIPS WILL BE PROVIDED AND INSTALLED APPROX. EVERY SIX-FEET ALONG THE NORTH SIDE OF THE CUTOFF WALL. THE DRAIN STRIPS SHALL BE PLACED WITH THE GEOTEXTILE SIDE AGAINST THE FORMWORK.
- DRAIN STRIPS WILL BE CONTINUOUS AND ANY SPLICES SHALL BE MADE WITH A ONE-FOOT MINIMUM OVERLAP SUCH THAT THE FLOW OF WATER IS NOT IMPEDED.
- DRAIN STRIPS SHALL EXTEND BEYOND THE FACE OF THE SHOTCRETE AT THE DOWNHILL FACE.
- DRAIN STRIPS SHALL BE MINIMUM 12" WIDE.

REINFORCING STEEL PLACEMENT:

- REINFORCING STEEL FOR THIS PROJECT SHALL BE EPOXY COATED OR GALVANIZED.
- WELDED WIRE MESH WILL BE PLACED ON BOTH SIDES OF THE EXTENDED 51mm MICROPILES AS SHOWN IN THESE DRAWINGS.
- NO. 5 REBAR WILL BE TIED TO THE SOUTH WIRE MESH. FOLLOW SPACING AND SPLICE LENGTHS AS SHOWN IN THESE DRAWINGS.
- NO. 5 REBAR WILL ALSO BE USED FOR THE MICROPILE CAP. FOLLOW SPACING AND SPLICE LENGTHS AS SHOWN IN THESE DRAWINGS.

MICROPILE CAP PLATES:

- 6" X 6" X 1/2" STEEL BEARING PLATES WILL BE PLACED OVER THE MICROPILES IN THE MICROPILE CAP AND ATTACHED WITH A HEX NUT TOP AND BOTTOM. IF THE MICROPILES EXTEND BEYOND THE TOP HEX NUTS, THEY WILL BE TRIMMED.

REINFORCED SOIL SLOPE (RSS) SYSTEM:

HIGH PERFORMANCE TURF REINFORCEMENT MAT (HPTRM)

- MATERIAL IS THREE-DIMENSIONAL, LOFTY WOVEN POLYPROPYLENE HPTRM
- MATRIX COMPOSED OF TRILOBAL MONOFILAMENT YARNS WOVEN INTO UNIFORM CONFIGURATION OF RESILIENT PYRAMID-LIKE PROJECTIONS THAT MINIMIZE WATERING REQUIREMENTS WHILE ENHANCING VEGETATION ESTABLISHMENT.
- MUST BE A HOMOGENEOUS MATRIX, AND NOT COMPRISED OF LAYERS, COMPOSITES, OR DISCONTINUOUS MATERIALS, OR OTHERWISE LOOSELY HELD TOGETHER BY STITCHED OR GLUED NETTING.
- THE HPTRM SHOULD MEET THE FOLLOWING VALUES:

PROPERTY	TEST METHOD	UNITS	MINIMUM REQUIREMENT
THICKNESS	ASTM D6525	IN	0.4
LIGHT PENETRATION	ASTM D6567	%	10
TENSILE STRENGTH	ASTM D6818	LB/FT	4000 X 3000
TENSILE ELONGATION	ASTM D6818	%	40 X 35
RESILIENCY	ASTM D6524	%	80
FLEXIBILITY	ASTM D6575	IN-LB	0.534
UV RESISTANCE	ASTM 4355	%	90 AT 6000 hrs

- WOOD OR PLASTIC STAKES, OR STEEL PINS ARE USED TO PIN-DOWN THE GEOTEXTILE NEAR THE BACK OF THE REINFORCEMENT ZONE TO HOLD THE GEOTEXTILE TAUT WHILE ALIGNING THE WALL FACE AND PLACING SOIL BACKFILL. THESE ARE INSTALLED AS NEEDED ALONG THE HPTRM, BUT AT A FREQUENCY NO LESS THAN 1 PER 6 LINEAL FEET. THE STAKES OR PINS SHALL BE 9 TO 12 IN LONG.
- BACKFILL WILL COMPRISE GENERAL FILL WITH A UNIFIED SOIL CLASSIFICATION SYSTEM DESIGNATION OF SILTY SAND (SM).
 - THE SM MATERIAL WILL CONSIST OF INERT EARTH MATERIALS WITH LESS THAN 3% ORGANICS OR OTHER DELETERIOUS SUBSTANCES.
 - FILL WILL BE PLACED IN UNIFORM, MAXIMUM 12-INCH LIFTS.
 - FILL IN THE UPPER 12 INCHES OF THE GRADED SLOPE FACE WILL NOT BE COMPACTED DUE TO LACK OF CONFINEMENT.
 - FILL BEHIND THE UPPER 12 INCHES OF THE GRADED SLOPE FACE WILL BE COMPACTED TO AT LEAST 90% OF THE MATERIALS MAXIMUM DRY DENSITY AND BE UNIFORMLY MOISTURE CONDITIONED TO AT LEAST THE OPTIMUM MOISTURE CONTENT AS DETERMINED BY ASTM D1557.

SHEET REVISIONS		
DATE	DESCRIPTION	NO
09/01/21	ISSUED FOR REVIEW	IFR
10/20/21	ISSUED FOR PERMIT	IFP

PROJECT NAME:
LAS BRISAS CONDOMINIUMS

SHEET TITLE:
GENERAL NOTES

THIS DRAWING IS FURNISHED SOLELY FOR THE USE OF OR IN CONNECTION WITH THIS PROJECT AND THE PROPRIETARY INFORMATION SHOWN HEREON IS NOT TO BE TRANSMITTED TO ANY OTHER ORGANIZATION WITHOUT SPECIFIC AUTHORIZATION BY GEOSTABILIZATION INTERNATIONAL (GSI). THE DESIGN IS ONLY VALID IF CONSTRUCTED AND SUPERVISED BY GSI OR ITS AUTHORIZED SUBCONTRACTOR.	DRAWN BY: MAC	CHECKED BY: JDR	DATE: 10/20/21	PROJECT NUMBER: 210487CA01	SHEET C-02
---	-------------------------	---------------------------	--------------------------	--------------------------------------	----------------------



GeoStabilization International®

Phone: 855.579.0536 | Fax: 970.245.7737
www.geostabilization.com



RSS ANCHOR DETAILS

TYPE B3 ANCHOR PROPERTIES

Component	Materials	Material Composition	Physical Properties
Anchor Head	Hot Dip Galvanized Ductile Iron		6.43 in x 1.84 in x 2.36 in (163.3 mm x 46.7 mm x 59.9 mm) Bearing Area: 10.3 in ² (66.5 cm ²)
Cable Tendon	Galvanized Steel		Diameter: 0.1875 in (4.8 mm)
Lower Termination	Aluminum		Length: 0.65 in (16.5 mm), Wall Thickness: 0.11 in (2.8 mm)
Load Bearing Plate	Zinc-Aluminum		5.98 in x 6.6 in x 0.75 in (151.9 mm x 167.6 mm x 19.1 mm) Bearing Area: 17.43 in ² (112.5 cm ²)
Top Termination	Zinc-Aluminum		Circumferential Tripple Wedge Grip Assembly to Eliminate Cable Pinch Points Grip to Cable Contact Surface Area: 0.505 in ² (3.3 cm ²) Grip to Cable Contact Ratio: 97% of Cable Diameter
Performance Properties			
Ultimate Assembly Strength	2800 lb (12.46 kN)	Typical Working Load	2000 lb (8.9 kN)
Ultimate Cable Strength	3700 lb (16.46 kN)	Embedment Depth	6-12 ft (1.83-3.66 m)

SHOTCRETE MIX DESIGN:

- SHOTCRETE SHALL COMPLY WITH THE REQUIREMENTS OF ACI 506.2, "SPECIFICATIONS FOR MATERIALS, PROPORTIONING AND APPLICATION OF SHOTCRETE", EXCEPT AS OTHERWISE SPECIFIED. SHOTCRETING CONSISTS OF APPLYING ONE OR MORE LAYERS OF CONCRETE CONVEYED THROUGH A HOSE PNEUMATICALLY PROJECTED AT A HIGH VELOCITY AGAINST A PREPARED SURFACE.
- THE WET-MIX PROCESS CONSISTS OF THOROUGHLY MIXING ALL THE INGREDIENTS, INTRODUCING THE MIXTURE INTO THE DELIVERY EQUIPMENT AND DELIVERING IT, BY POSITIVE DISPLACEMENT, TO THE NOZZLE. AIR JET THE WET-MIX SHOTCRETE FROM THE NOZZLE AT HIGH VELOCITY ONTO THE SURFACE.
- GSI STANDARD SHOTCRETE MIX DESIGN SHALL BE USED UNLESS SHOTCRETE TEMPERATURES ARE ANTICIPATED TO REACH AND/OR EXCEED 85°F. IN THIS EVENT, GSI HOT WEATHER MIX MAY BE USED. SET TIME CONTROLLING ADDITIVES (I.E. HYDRATION STABILIZERS, RETARDERS) MAY BE USED PER THE MANUFACTURER SPECIFICATIONS AND UNDER THE DIRECTION OF A GSI ENGINEER.

GSI STANDARD SHOTCRETE MIX DESIGN (PER YD ³)		
MATERIAL	DESCRIPTION	WEIGHT (LBS)
AGGREGATE NO. 1	3/4" ROCK, AASHTO M80, CLASS B	650
AGGREGATE NO. 2	CONCRETE SAND, CLEAN, NATURAL	1800
AIR	6% TOTAL	--
WATER	CLEAN AND POTABLE	300
FLY ASH	TYPE F OR C	150
CEMENT	TYPE V	750
TOTAL	--	3710

GSI HOT WEATHER SHOTCRETE MIX DESIGN (PER YD ³)		
MATERIAL	DESCRIPTION	WEIGHT (LBS.)
AGGREGATE NO. 1	3/4" ROCK, AASHTO M80, CLASS B	600
AGGREGATE NO. 2	CONCRETE SAND, CLEAN, NATURAL	1800
AIR	6% TOTAL	--
WATER	CLEAN AND POTABLE	315
FLY ASH	TYPE F OR C	300
CEMENT	TYPE V	700
TOTAL	--	3710

SHOTCRETE APPLICATION:

- SHOTCRETE APPLICATION WILL GENERALLY COMPLY WITH ACI 506.2-13 UNLESS DIRECTED BY GSI ENGINEER OR THEIR DESIGNATED REPRESENTATIVE.
- SHOTCRETE WILL BE PLACED FROM THE LOWER PART OF THE AREA UPWARDS TO PREVENT ACCUMULATION OF REBOUND. THE NOZZLE WILL BE ORIENTED A PROPER DISTANCE FROM AND APPROXIMATELY PERPENDICULAR TO THE WORKING FACE SO THAT REBOUND WILL BE MINIMAL AND COMPACTION WILL BE MAXIMIZED.
- CARE WILL BE TAKEN WHILE ENCASING REINFORCING STEEL AND MESH TO KEEP THE FRONT FACE OF THE REINFORCEMENT CLEAN DURING PLACEMENT OPERATIONS, SO THAT SHOTCRETE BUILDS UP FROM BEHIND, TO ENCASE THE REINFORCEMENT AND PREVENT VOIDS OR POCKETS FROM FORMING.
- SHOTCRETE THICKNESS TOLERANCE SHALL BE MINUS ONE INCH - PLUS TWO INCHES.

GROUT MIX DESIGN:

- STANDARD GROUT MIX DESIGN TO BE USED IN SOIL DRILLING.
- IF SLOWER DRILLING IS EXPERIENCED WHILE DRILLING IN ROCK GSI ENGINEERS MAY APPROVE USE OF DRILLING GROUT MIX DESIGN. UPON COMPLETION OF DRILLING TO SPECIFIED DEPTH WITH DRILLING GROUT MIX HOLE SHOULD BE FLUSHED WITH STANDARD GROUT MIX AND NAIL HOLE SWABBED TO AID IN DRILLING GROUT MIX REPLACEMENT.
- IF VOIDS ARE ENCOUNTERED AND GROUT LOSS IS EXPERIENCED CONTACT GSI ENGINEERS AND CUT OFF GROUT PUMPING FOR THAT ELEMENT WHEN DRILLING DEPTH IS REACHED AND A TOTAL OF 3 BAGS OF GROUT SLURRY PER 10' STICK OF BAR HAS BEEN USED.
- THE GROUT WILL BE A TYPE III/IV PORTLAND CEMENT. THE WATER/CEMENT RATIO WILL BE 0.5 TO 0.6. NO ADDITIONAL AGGREGATE OR ADMIXTURES WILL BE ADDED TO THE GROUT.

STANDARD GROUT MIX DESIGN			
MATERIAL	WEIGHT (LBS.)	VOLUME (FT ³)	FIELD UNIT VOLUME
WATER	235-282	3.8-4.5	28 - 34 GALLONS
CEMENT (TYPE I/II)	470	2.4	5 BAGS (94 LBS.)
TOTAL UNIT	705 - 752	6.1 - 6.9	--
W/C RATIO	--	--	0.5 - 0.6
SPECIFIC GRAVITY	--	--	1.84 - 1.75

DRILLING GROUT MIX DESIGN			
MATERIAL	WEIGHT (LBS.)	VOLUME (FT ³)	FIELD UNIT VOLUME
WATER	235-282	3.8-4.5	28 - 34 GALLONS
CEMENT (TYPE I/II)	188	0.9	2 BAGS (94 LBS.)
TOTAL UNIT	423 - 470	4.7 - 5.5	--
W/C RATIO	--	--	1.25 - 1.5
SPECIFIC GRAVITY	--	--	1.44 - 1.38

QUALITY CONTROL:

- GSI WILL CONDUCT OR OBTAIN QUALIFIED PERSONNEL TO CONDUCT THE FOLLOWING QUALITY CONTROL TESTING DURING THE PROJECT.

QUALITY CONTROL SCHEDULE		
DESCRIPTION	FREQUENCY	REFERENCE/ CRITERIA
DILL LOGS	EVERY MICROPILE	RECORD DATA PER SHEET C-14
PROOF NAIL TEST	5% OF PRODUCTION NAILS, TEST AFTER 48 HRS	FHWA 05-039, 2005
MUD BALANCE READINGS (SPECIFIC GRAVITY)	ONCE EACH DAY OF GROUTING	SEE SHEET C-03 & C-14 FOR MIX DESIGN AND DATA LOG
GROUT CUBES	1 SET OF 3 CUBES PER EVERY 10 PILES INSTALLED	ASTM C-109/AASHTO T106. 3, 7 & 28 DAY STRENGTH. 4000 PSI 28-DAY.
SHOTCRETE PANELS	2 PRODUCTION PANELS THROUGHOUT PROJECT	ASTM C1140, 1500 PSI. 3, 7 & 28 DAY STRENGTH. 5000 PSI 28-DAY.

SHEET REVISIONS

DATE	DESCRIPTION	NO
09/01/21	ISSUED FOR REVIEW	IFR
10/20/21	ISSUED FOR PERMIT	IFP

PROJECT NAME:
LAS BRISAS CONDOMINIUMS

SHEET TITLE:
GENERAL NOTES (CONT.)

THIS DRAWING IS FURNISHED SOLELY FOR THE USE OF OR IN CONNECTION WITH THIS PROJECT AND THE PROPRIETARY INFORMATION SHOWN HEREON IS NOT TO BE TRANSMITTED TO ANY OTHER ORGANIZATION WITHOUT SPECIFIC AUTHORIZATION BY GEOSTABILIZATION INTERNATIONAL (GSI). THE DESIGN IS ONLY VALID IF CONSTRUCTED AND SUPERVISED BY GSI OR ITS AUTHORIZED SUBCONTRACTOR.

DRAWN BY: MAC	CHECKED BY: JDR	DATE: 10/20/21	PROJECT NUMBER: 210487CA01	SHEET C-03
-------------------------	---------------------------	--------------------------	--------------------------------------	----------------------



Phone: 855.579.0536 | Fax: 970.245.7737
www.geostabilization.com



C:\Users\jacob\OneDrive\Documents\Projects\210487CA01\210487CA01-03-02.dwg - 10/20/21 4:11 PM

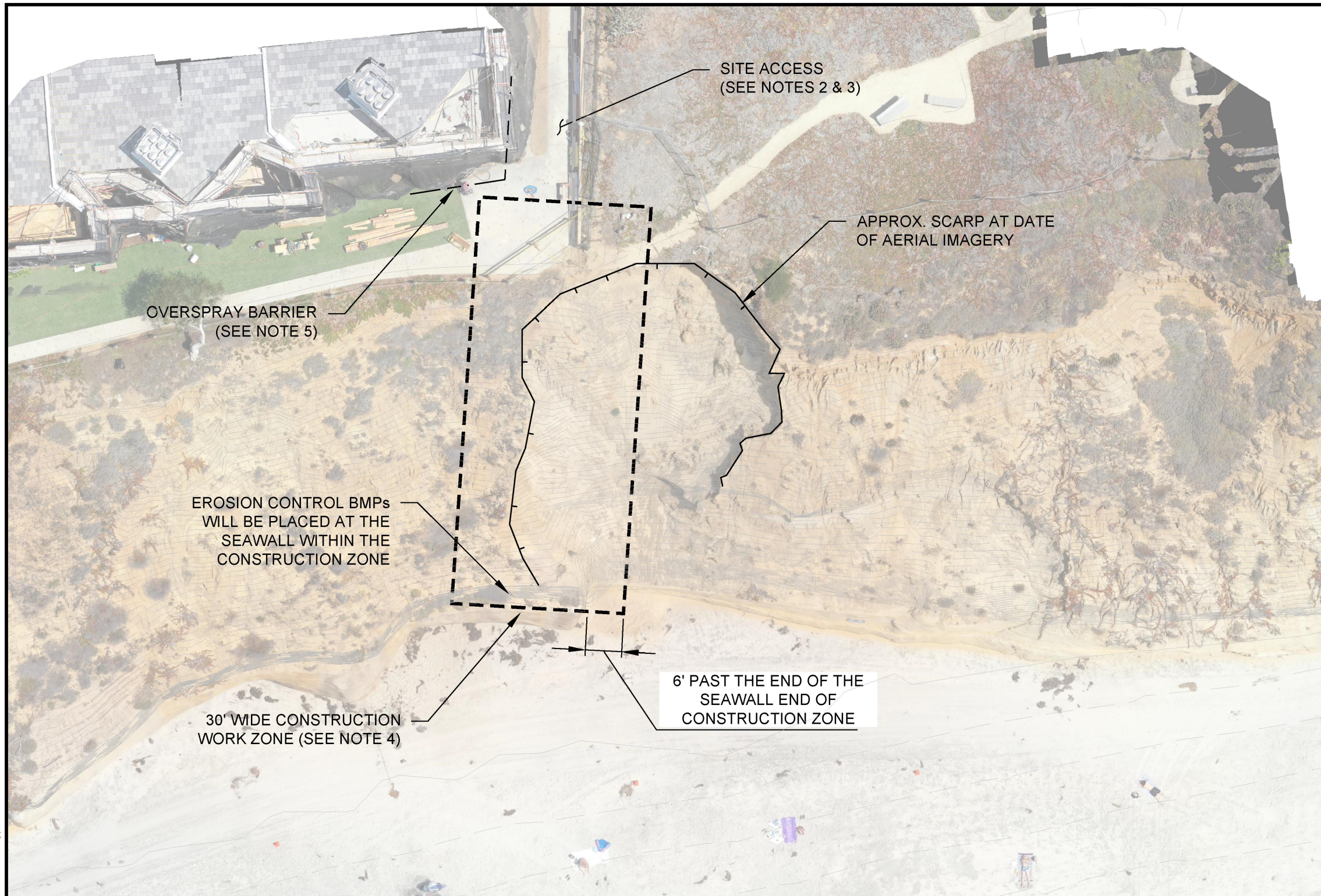

NOTES:

1. BACKGROUND IMAGE OBTAINED FROM GSI DRONE FLIGHT AERIAL IMAGERY, FLOWN ON 8/25/21. EXISTING TOPOGRAPHY DATA OBTAINED FROM PASCO LARET SUITER & ASSOCIATES, PLSA JOB #2710.
2. CONSTRUCTION ACCESS CORRIDOR IS LOCATED ALONG THE SOUTH SIDE OF THE LAS BRISAS CONDOMINIUMS. CARE SHOULD BE TAKEN TO LIMIT IMPACT TO THE CONDOMINIUM AND PUBLIC ACCESS IN THE AREA.
3. CONSTRUCTION MATERIALS AND EQUIPMENT SHALL BE MOVED FROM THE STAGING SITE AND RESTORE THE STAGING TO ITS PRIOR-TO-CONSTRUCTION CONDITION WITHIN 72 HRS FOLLOWING COMPLETION OF THE PROJECT.
4. GSI TO PROVIDE CONSTRUCTION BARRIER DURING WORKING HOURS TO SEPARATE WORK ZONE FROM OPEN PUBLIC BEACH. LATERAL PUBLIC ACCESS SHALL BE PROVIDED PAST THE SITE AT ALL TIMES.
5. GSI WILL USE A PLASTIC OR SIMILAR BARRIER TO PROTECT THE BUILDING FROM SHOTCRETE OVERSPRAY. ANTICIPATE DRAPING FROM THE 3RD DECK TO GROUND LEVEL.

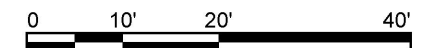
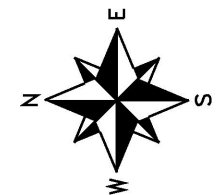

SHEET REVISIONS

DATE	DESCRIPTION	NO
09/01/21	ISSUED FOR REVIEW	IFR
10/20/21	ISSUED FOR PERMIT	IFP

PROJECT NAME:
LAS BRISAS CONDOMINIUMS

SHEET TITLE:
EXISTING SITE & ACCESS PLAN

THIS DRAWING IS FURNISHED SOLELY FOR THE USE OF OR IN CONNECTION WITH THIS PROJECT AND THE PROPRIETARY INFORMATION SHOWN HEREON IS NOT TO BE TRANSMITTED TO ANY OTHER ORGANIZATION WITHOUT SPECIFIC AUTHORIZATION BY GEOSTABILIZATION INTERNATIONAL (GSI). THE DESIGN IS ONLY VALID IF CONSTRUCTED AND SUPERVISED BY GSI OR ITS AUTHORIZED SUBCONTRACTOR.

DRAWN BY: MAC	CHECKED BY: JDR	DATE: 10/20/21	PROJECT NUMBER: 210487CA01	SHEET C-04
-------------------------	---------------------------	--------------------------	--------------------------------------	----------------------



Phone: 855.579.0536 | Fax: 970.245.7737
www.geostabilization.com



C:\Users\mac\OneDrive\Documents\Projects\210487CA01\Las Brisas Condominiums\210487CA01_ExistingSiteAccessPlan.dwg - 10/20/21 4:11 PM

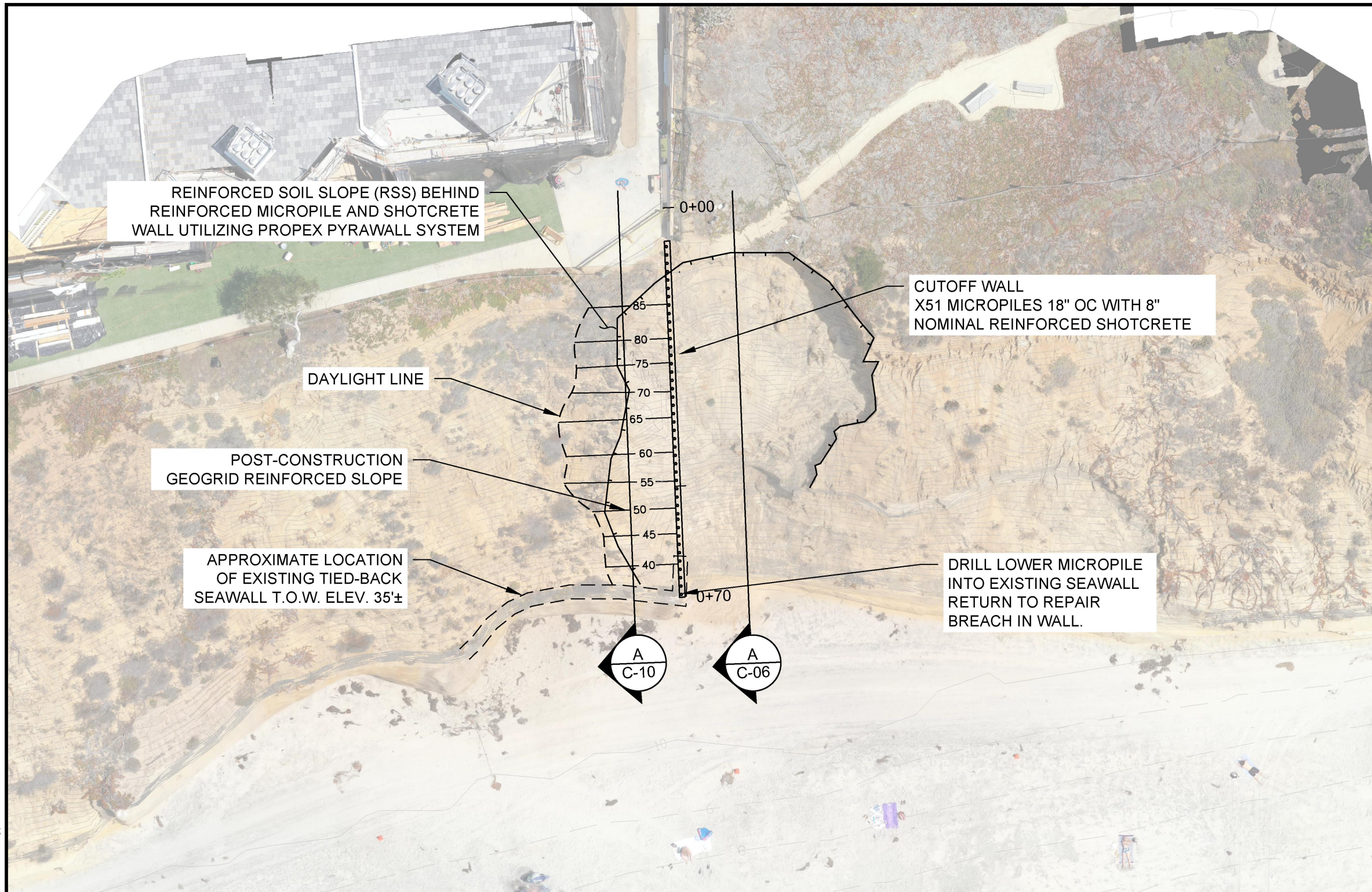

- NOTES:
- BACKGROUND IMAGE OBTAINED FROM GSI DRONE FLIGHT ON 8/25/21. EXISTING TOPOGRAPHY DATA OBTAINED FROM PASCO LARET SUITER & ASSOCIATES, PLSA JOB #2710.

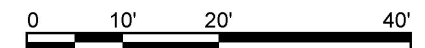
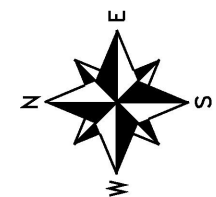

SHEET REVISIONS

DATE	DESCRIPTION	NO
09/01/21	ISSUED FOR REVIEW	IFR
10/20/21	ISSUED FOR PERMIT	IFP

PROJECT NAME:
LAS BRISAS CONDOMINIUMS

SHEET TITLE:
PROJECT SITE PLAN

DRAWN BY: MAC	CHECKED BY: JDR	DATE: 10/20/21	PROJECT NUMBER: 210487CA01	SHEET C-05
------------------	--------------------	-------------------	-------------------------------	---------------



Phone: 855.579.0536 | Fax: 970.245.7737
www.geostabilization.com



THIS DRAWING IS FURNISHED SOLELY FOR THE USE OF OR IN CONNECTION WITH THIS PROJECT AND THE PROPRIETARY INFORMATION SHOWN HEREON IS NOT TO BE TRANSMITTED TO ANY OTHER ORGANIZATION WITHOUT SPECIFIC AUTHORIZATION BY GEOSTABILIZATION INTERNATIONAL (GSI). THE DESIGN IS ONLY VALID IF CONSTRUCTED AND SUPERVISED BY GSI OR ITS AUTHORIZED SUBCONTRACTOR.

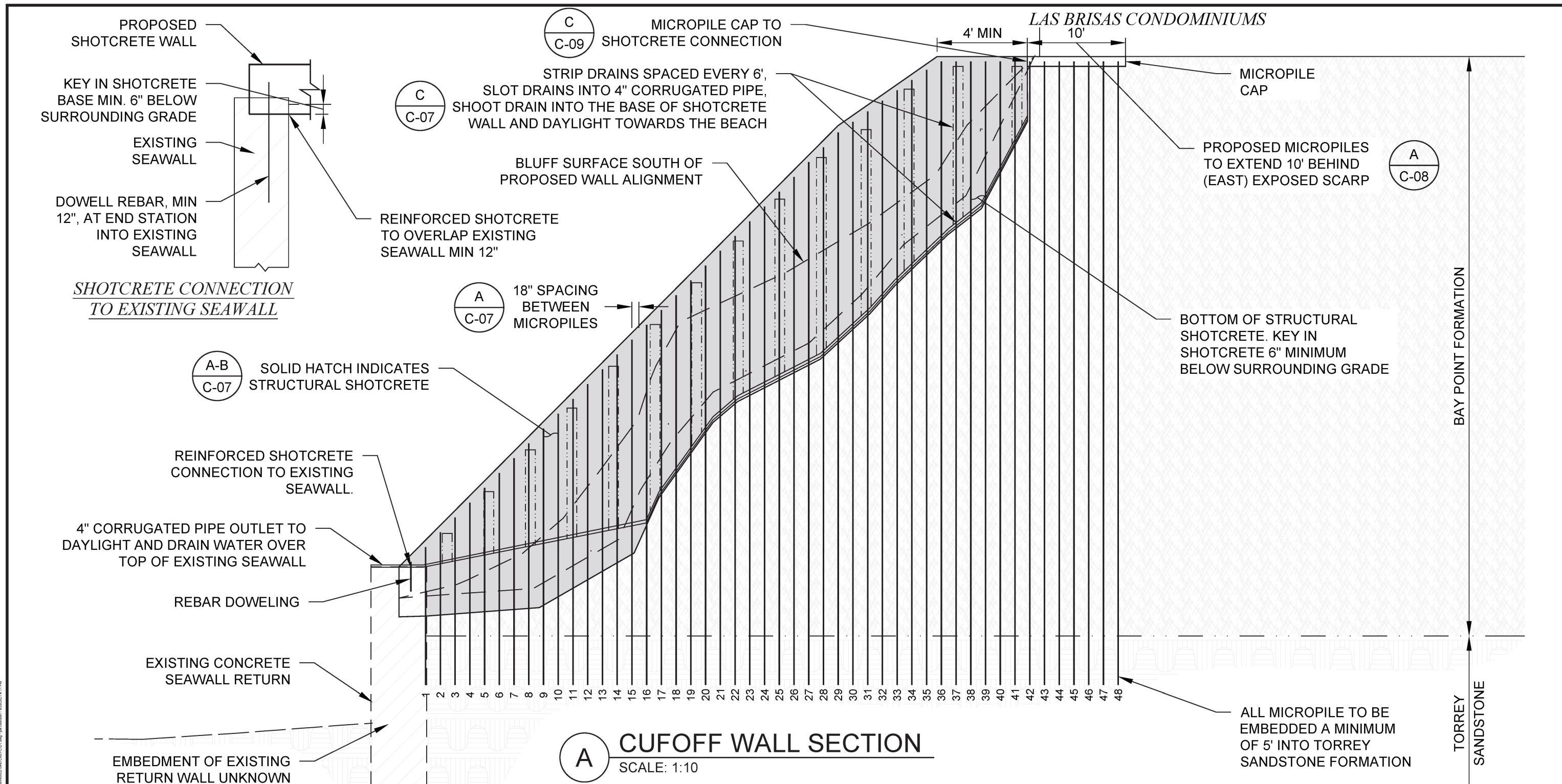

A CUTOFF WALL SECTION
SCALE: 1:10

SHEET REVISIONS		
DATE	DESCRIPTION	NO
09/01/21	ISSUED FOR REVIEW	IFR
10/20/21	ISSUED FOR PERMIT	IFP

PROJECT NAME:
LAS BRISAS CONDOMINIUMS

SHEET TITLE:
SECTION VIEW - CUTOFF WALL

THIS DRAWING IS FURNISHED SOLELY FOR THE USE OF OR IN CONNECTION WITH THIS PROJECT AND THE PROPRIETARY INFORMATION SHOWN HEREON IS NOT TO BE TRANSMITTED TO ANY OTHER ORGANIZATION WITHOUT SPECIFIC AUTHORIZATION BY GEOSTABILIZATION INTERNATIONAL (GSI). THE DESIGN IS ONLY VALID IF CONSTRUCTED AND SUPERVISED BY GSI OR ITS AUTHORIZED SUBCONTRACTOR.

DRAWN BY: MAC	CHECKED BY: JDR	DATE: 10/20/21	PROJECT NUMBER: 210487CA01	SHEET C-06
------------------	--------------------	-------------------	-------------------------------	---------------

Phone: 855.579.0536 | Fax: 970.245.7737
www.geostabilization.com



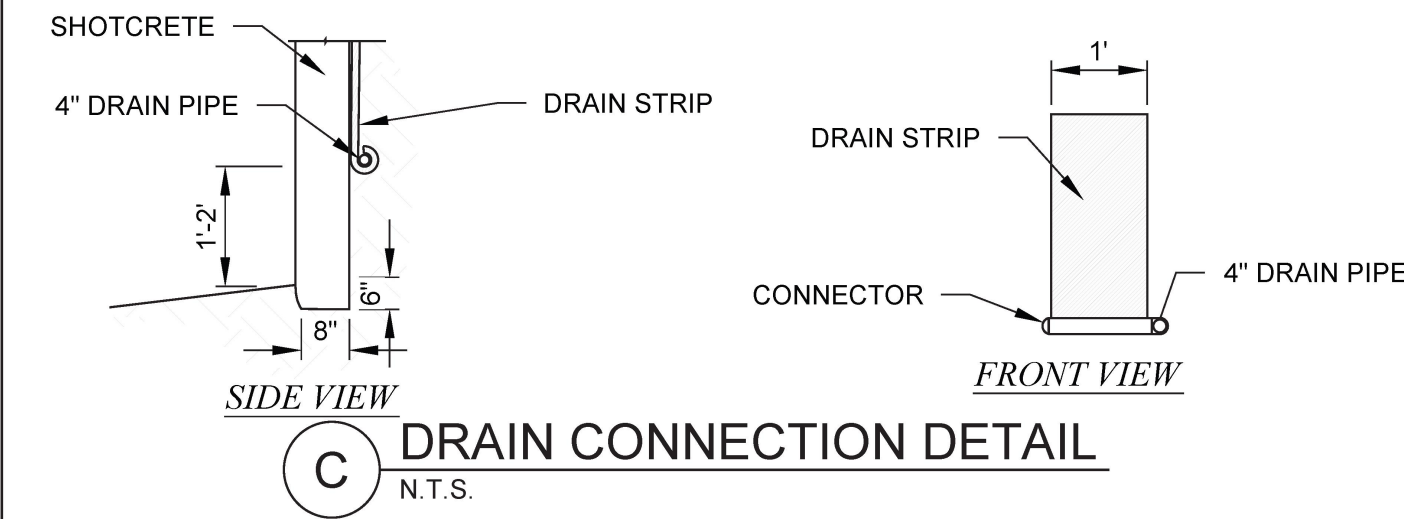
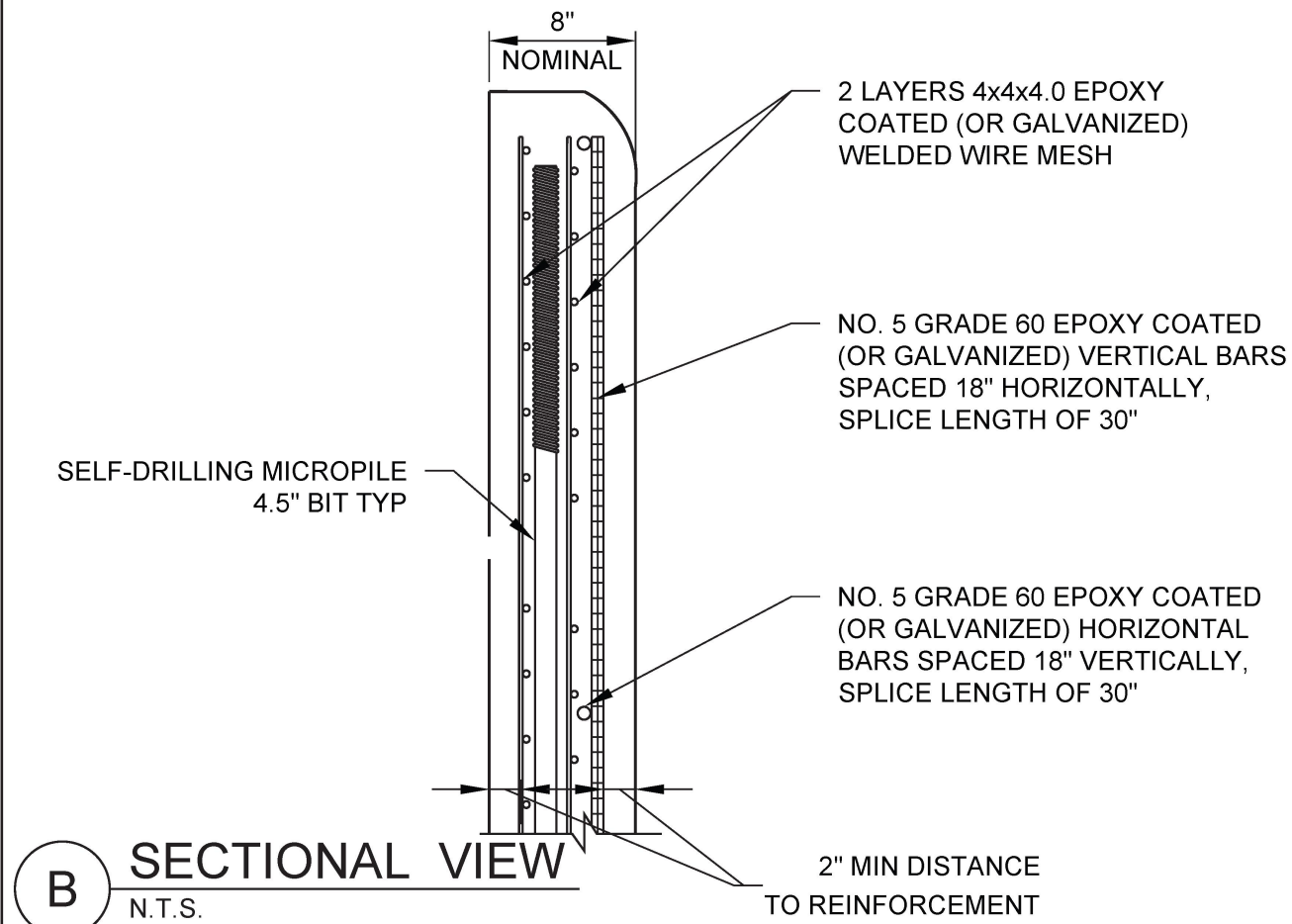
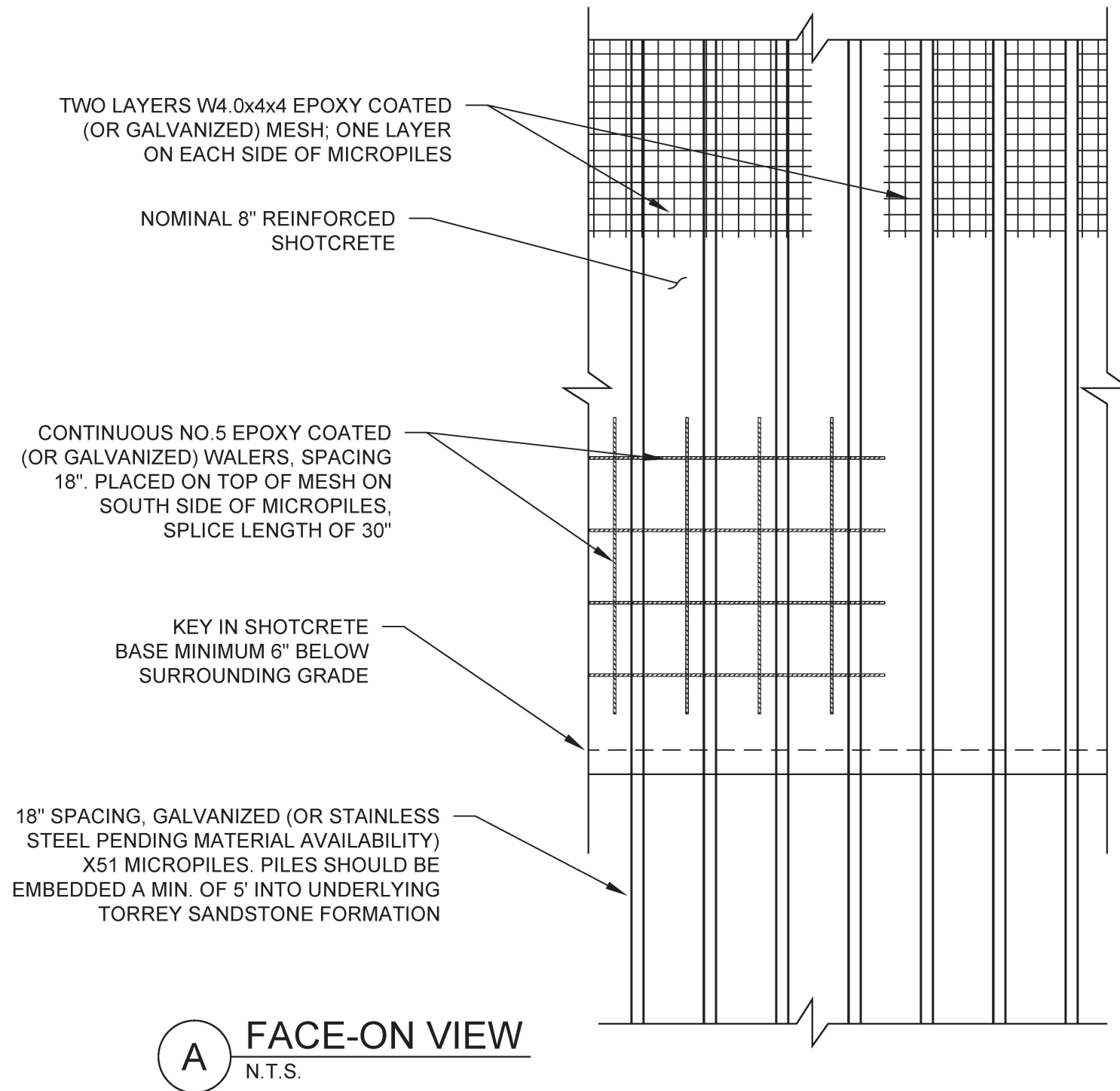

SHEET REVISIONS

DATE	DESCRIPTION	NO
09/01/21	ISSUED FOR REVIEW	IFR
10/20/21	ISSUED FOR PERMIT	IFP

PROJECT NAME:
LAS BRISAS CONDOMINIUMS

SHEET TITLE:
CUTOFF WALL DETAILS

DRAWN BY: **MAC** CHECKED BY: **JDR** DATE: **10/20/21** PROJECT NUMBER: **210487CA01** SHEET: **C-07**



Phone: 855.579.0536 | Fax: 970.245.7737
www.geostabilization.com



C:\Users\mlozano\OneDrive\Documents\Projects\210487CA01 - Las Brisas Condominiums\Drawings\210487CA01-C-07.dwg, 10/20/21 4:11 PM

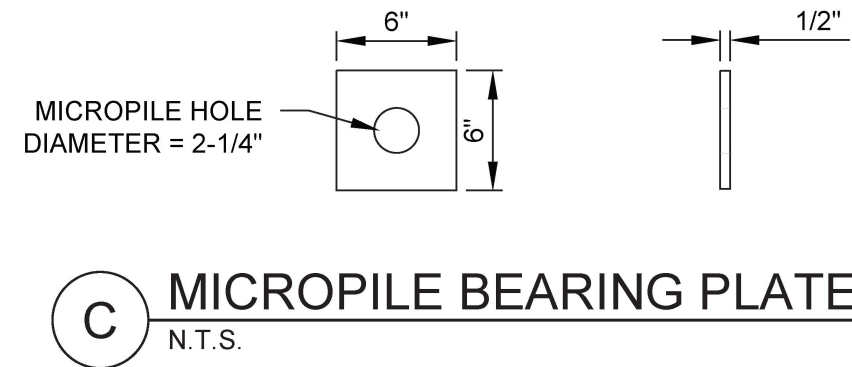
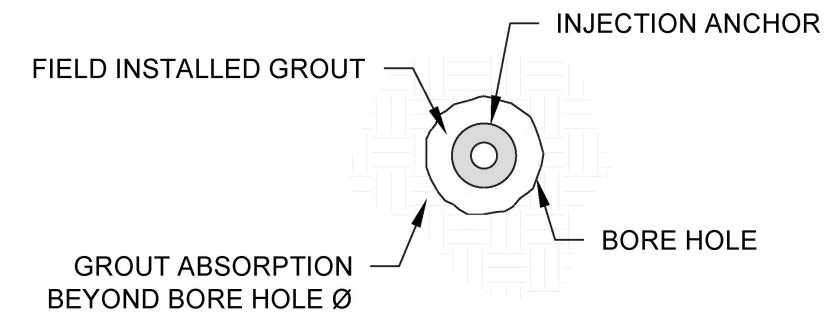
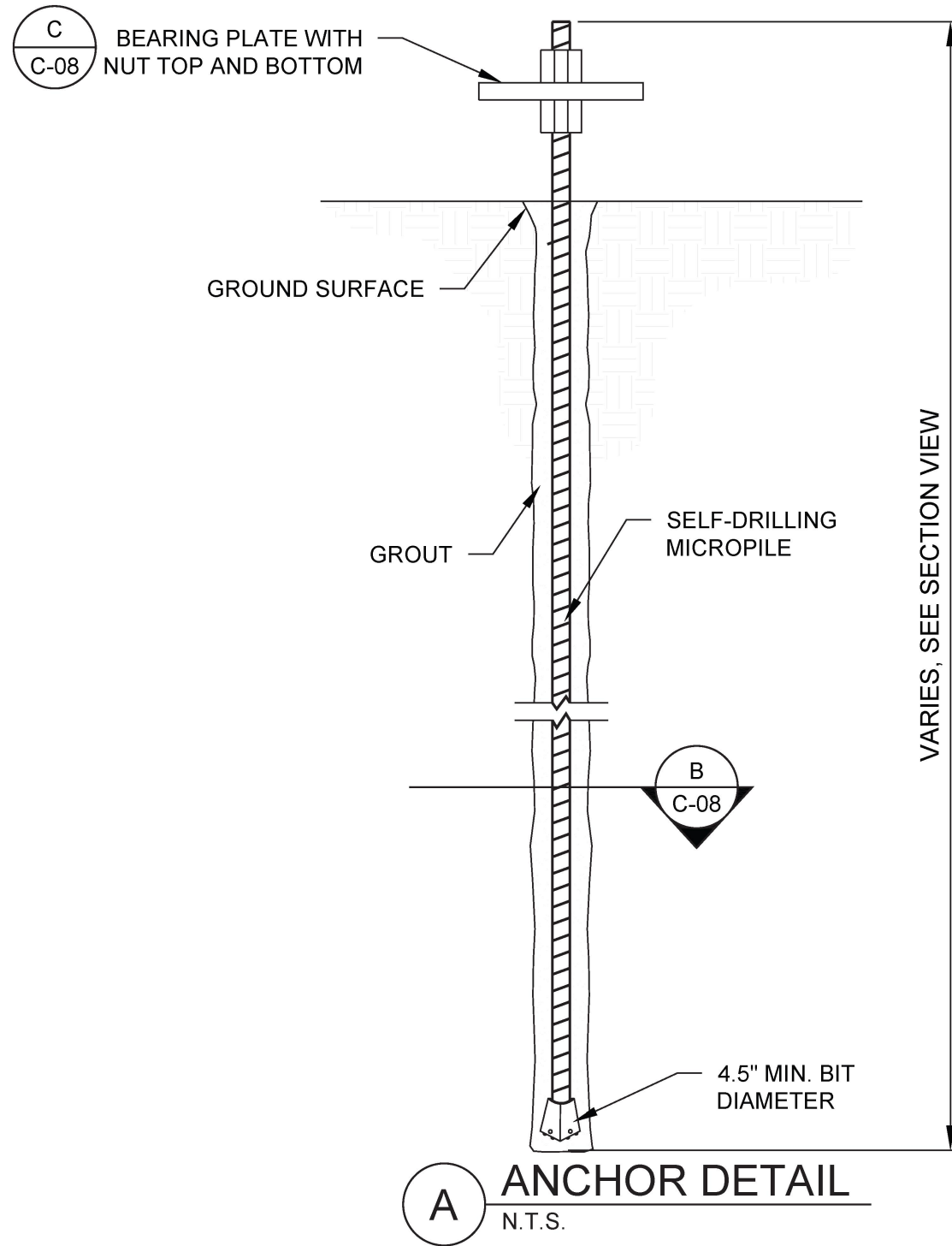

SHEET REVISIONS

DATE	DESCRIPTION	NO
09/01/21	ISSUED FOR REVIEW	IFR
10/20/21	ISSUED FOR PERMIT	IFP

PROJECT NAME:
LAS BRISAS CONDOMINIUMS

SHEET TITLE:
MICROPILE ANCHOR DETAILS

THIS DRAWING IS FURNISHED SOLELY FOR THE USE OF OR IN CONNECTION WITH THIS PROJECT AND THE PROPRIETARY INFORMATION SHOWN HEREON IS NOT TO BE TRANSMITTED TO ANY OTHER ORGANIZATION WITHOUT SPECIFIC AUTHORIZATION BY GEOSTABILIZATION INTERNATIONAL (GSI). THE DESIGN IS ONLY VALID IF CONSTRUCTED AND SUPERVISED BY GSI OR ITS AUTHORIZED SUBCONTRACTOR.

DRAWN BY: MAC	CHECKED BY: JDR	DATE: 10/20/21	PROJECT NUMBER: 210487CA01	SHEET C-08
------------------	--------------------	-------------------	-------------------------------	---------------



Phone: 855.579.0536 | Fax: 970.245.7737
www.geostabilization.com



C:\Users\mlozano\OneDrive\Desktop\Projects\210487CA01 - Las Brisas Condominiums\BIM\210487CA01-08-C08.dwg 10/20/21 4:11 PM

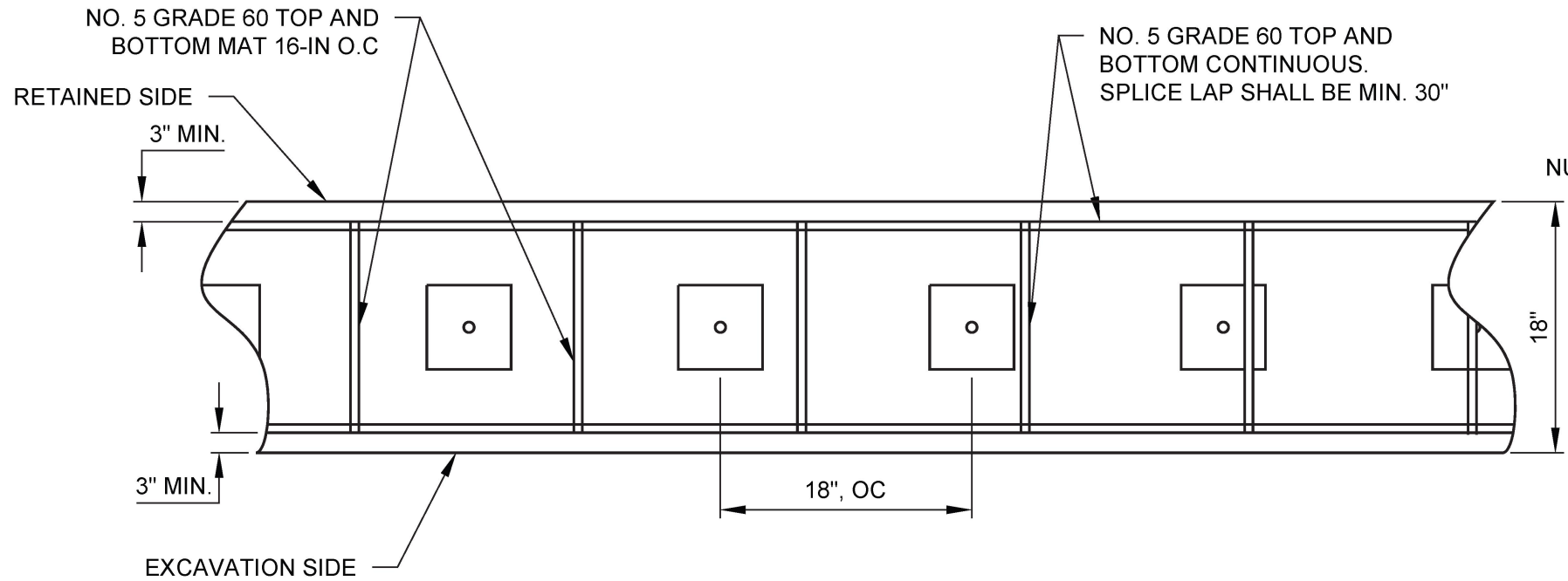

A MICROPILES - TOP VIEW
N.T.S.

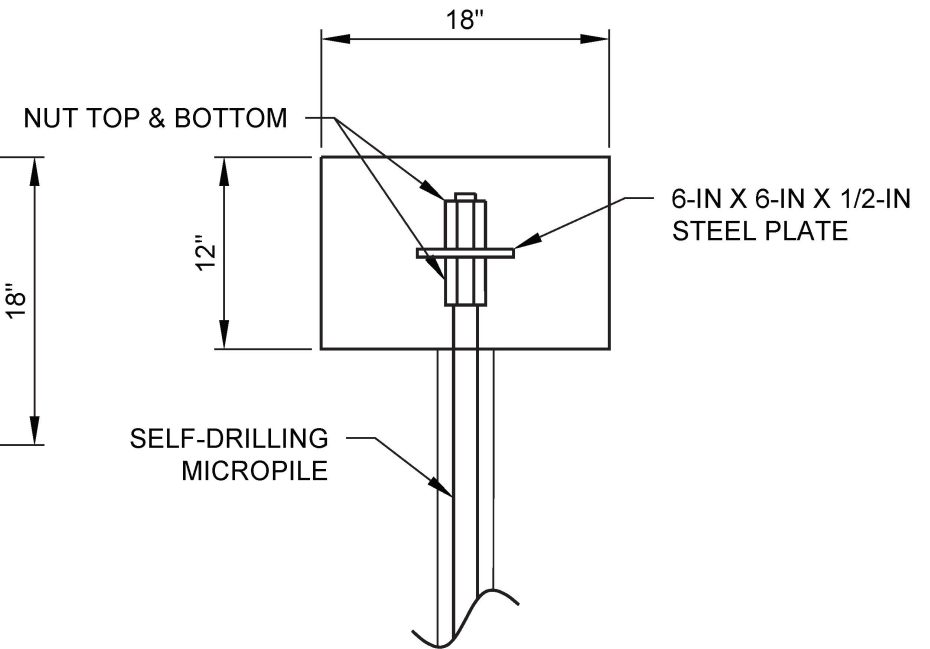

B MICROPILES - END VIEW
N.T.S.

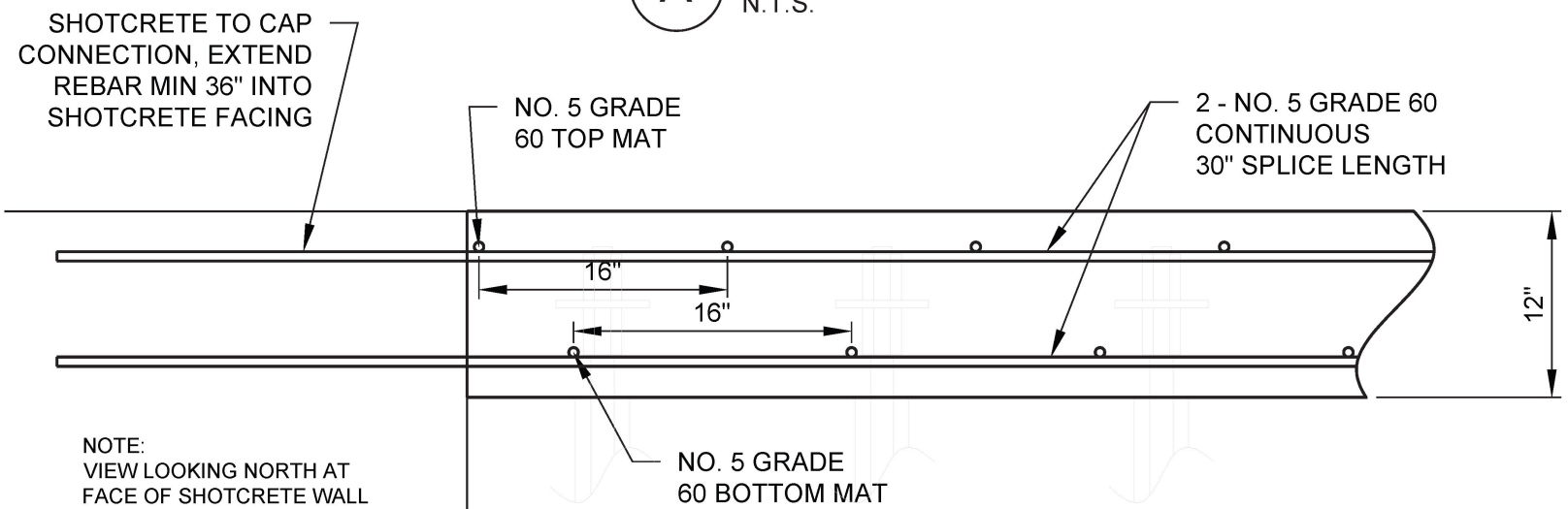

C MICROPILES - SIDE VIEW
N.T.S.

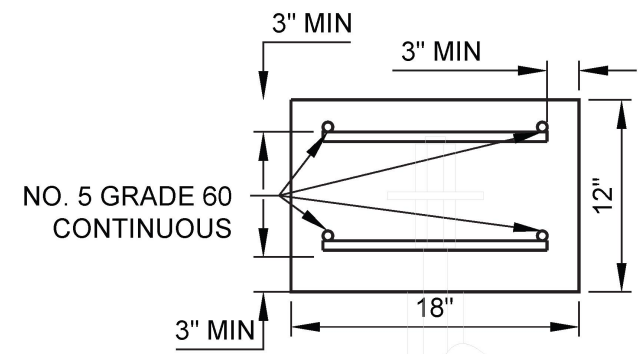

D REINFORCEMENT - END VIEW
N.T.S.

SHEET REVISIONS

DATE	DESCRIPTION	NO
09/01/21	ISSUED FOR REVIEW	IFR
10/20/21	ISSUED FOR PERMIT	IFP

PROJECT NAME:
LAS BRISAS CONDOMINIUMS

SHEET TITLE:
MICROPILE CAP DETAILS

DRAWN BY: MAC	CHECKED BY: JDR	DATE: 10/20/21	PROJECT NUMBER: 210487CA01	SHEET C-09
------------------	--------------------	-------------------	-------------------------------	---------------



Phone: 855.579.0536 | Fax: 970.245.7737
www.geostabilization.com



C:\Users\mccormac\OneDrive\Desktop\Projects\210487CA01 - Las Brisas Condominiums\Revit\210487CA01-09-01-21.dwg - 10/20/21 4:11 PM

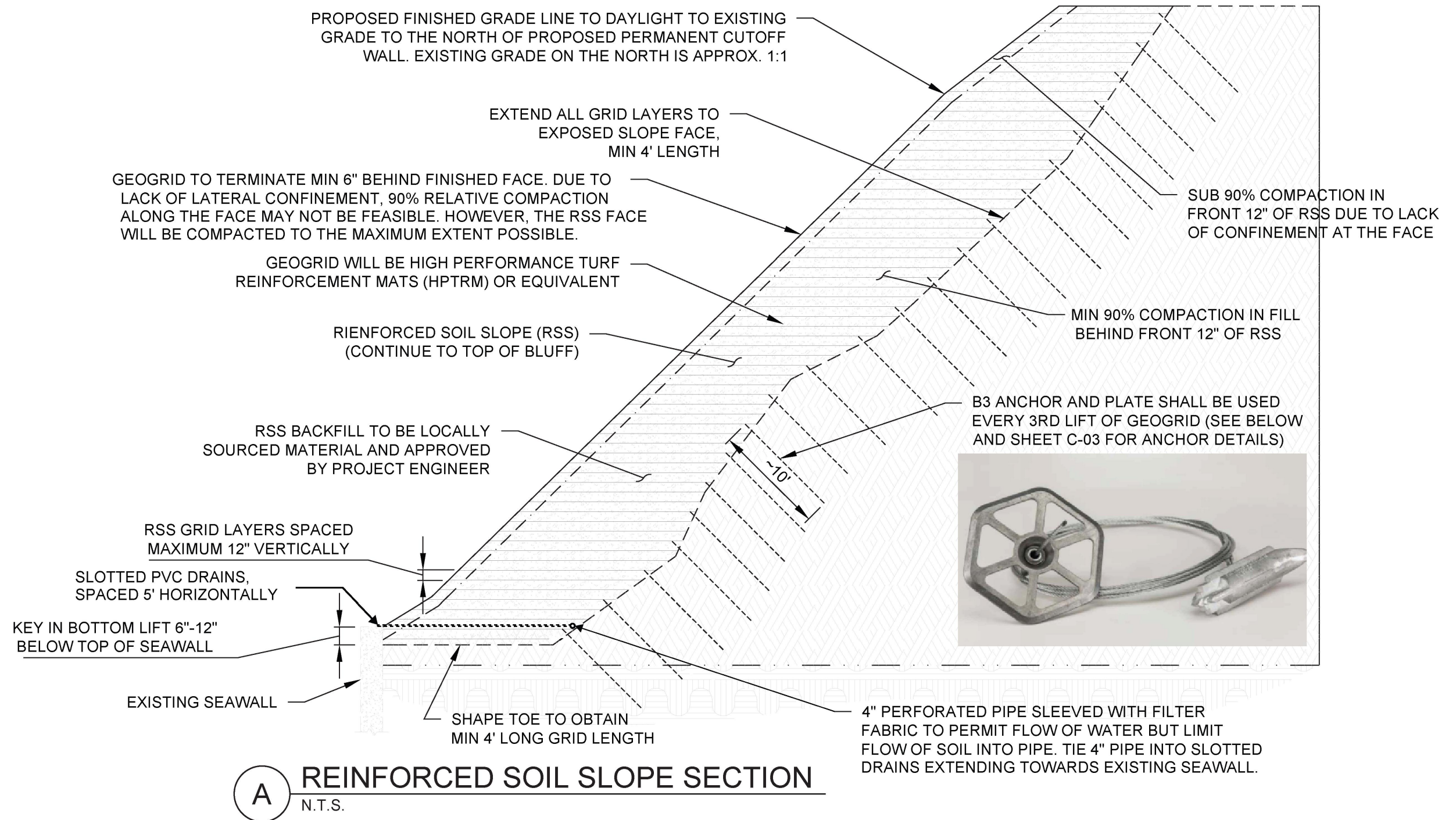

SHEET REVISIONS		
DATE	DESCRIPTION	NO
09/01/21	ISSUED FOR REVIEW	IFR
10/20/21	ISSUED FOR PERMIT	IFP

PROJECT NAME:
LAS BRISAS CONDOMINIUMS

SHEET TITLE:
SECTION VIEW - RSS SYSTEM

DRAWN BY: MAC	CHECKED BY: JDR	DATE: 10/20/21	PROJECT NUMBER: 210487CA01	SHEET C-10
------------------	--------------------	-------------------	-------------------------------	---------------

GSI
GeoStabilization International®

Phone: 855.579.0536 | Fax: 970.245.7737
www.geostabilization.com



C:\Users\mac\OneDrive\Documents\Projects\Las Brisas Condominiums\Las Brisas Condominiums - RSS System\Section View - RSS System.dwg - 10/20/21 4:11 PM

LAS BRISAS CONDOMINIUMS

10'

PHASE I MICROPILES AND CAP

PHASE I REINFORCED SHOTCRETE CUTOFF WALL

- ADDITIONAL REINFORCED SHOTCRETE AND BLUFF STABILIZATION ELEMENTS WILL BE REQUIRED TO MITIGATE GLOBAL FAILURE OF CUTOFF WALL ONCE EXPOSED DUE TO NATURAL EROSIONAL PROCESSES.
- TRIGGER ALARMS FOR PHASE II EROSION MITIGATION:
 1. MICROPILES BELOW BASE OF SHOTCRETE FACING BECOME EXPOSED UP TO 6', AND/OR
 2. FLOW OF RSS BACKFILL TOWARDS SOUTH AND BETWEEN MICROPILES.

SHEET REVISIONS

DATE	DESCRIPTION	NO
09/01/21	ISSUED FOR REVIEW	IFR
10/20/21	ISSUED FOR PERMIT	IFP

PROJECT NAME:
LAS BRISAS CONDOMINIUMS

SHEET TITLE:
PHASE II MITIGATION SECTION



Phone: 855.579.0536 | Fax: 970.245.7737
www.geostabilization.com



THIS DRAWING IS FURNISHED SOLELY FOR THE USE OF OR IN CONNECTION WITH THIS PROJECT AND THE PROPRIETARY INFORMATION SHOWN HEREON IS NOT TO BE TRANSMITTED TO ANY OTHER ORGANIZATION WITHOUT SPECIFIC AUTHORIZATION BY GEOSTABILIZATION INTERNATIONAL (GSI). THE DESIGN IS ONLY VALID IF CONSTRUCTED AND SUPERVISED BY GSI OR ITS AUTHORIZED SUBCONTRACTOR.

DRAWN BY: MAC	CHECKED BY: JDR	DATE: 10/20/21	PROJECT NUMBER: 210487CA01	SHEET C-11
------------------	--------------------	-------------------	-------------------------------	---------------

C:\Users\mlozano\OneDrive\Documents\Projects\210487CA01 - Las Brisas Condominiums\Bldg\210487CA01-11.dwg, 10/20/21 4:11 PM

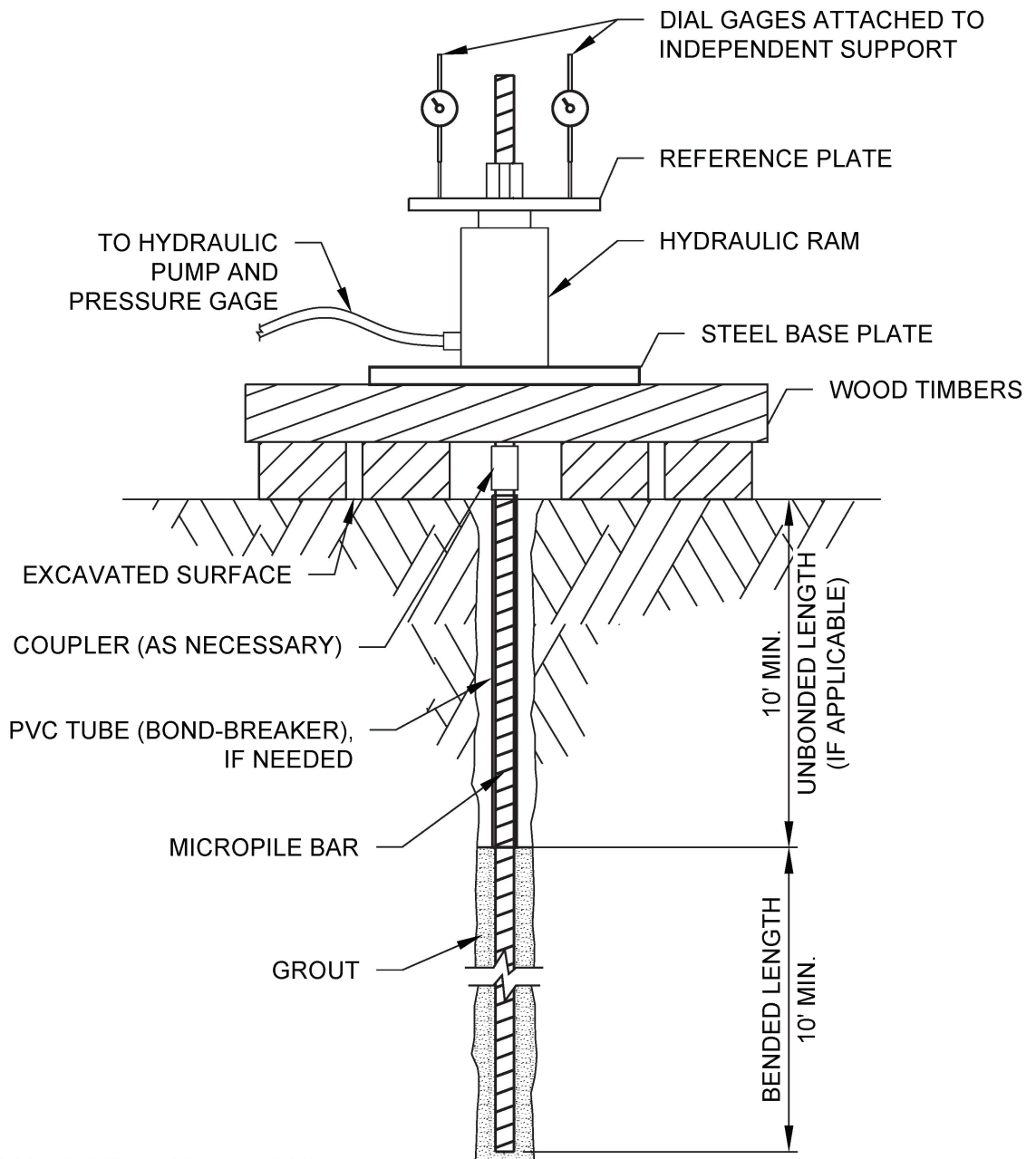

PROOF MICROPILE TESTING PROCEDURE AND EQUIPMENT:

- THE REACTION FRAME WILL BE SUFFICIENTLY RIGID AND OF ADEQUATE DIMENSIONS SO THAT EXCESSIVE DEFORMATION OF THE TESTING EQUIPMENT DOES NOT OCCUR. THE REACTION FRAME WILL BE SUPPORTED INDEPENDENTLY OF THE MICROPILE BAR. THE CONFIGURATION OF THE TESTING APPARATUS WILL BE POSITIONED TO REDUCE THE POTENTIAL OF THE NEED FOR THE RAM, BEARING PLATES, AND STRESSING ANCHORAGE TO BE REPOSITIONED DURING A TEST.
- THE LOAD WILL BE APPLIED WITH A HYDRAULIC RAM AND MEASURED WITH A PRESSURE GAUGE. THE PRESSURE GAUGE WILL BE GRADUATED IN 100 PSI INCREMENTS OR LESS. THE RAM, PRESSURE GAUGES, AND PUMPS WILL HAVE BEEN CALIBRATED WITH EACH OTHER WITHIN THE LAST YEAR BY AN INDEPENDENT AASHTO ACCREDITED LABORATORY OR BY A DEPARTMENT LABORATORY.
- MOVEMENT OF THE BAR HEAD SHALL BE MEASURED WITH AT LEAST ONE DIAL GAUGE CAPABLE OF MEASURING TO THE NEAREST 0.001 INCH. THE GAUGE WILL BE VISUALLY ALIGNED TO BE PARALLEL WITH THE AXIS OF THE BAR AND SHALL BE SUPPORTED INDEPENDENTLY OF THE RAM AND REACTION FRAME. GENERALLY TWO DIAL GAUGES ARE UTILIZED, IF POSSIBLE.
- TESTING SHALL BE PERFORMED BY INCREMENTALLY LOADING THE BAR PER TO THE LOADING SCHEDULE PROVIDED BELOW. THE BAR HEAD MOVEMENTS SHALL BE RECORDED AT EACH LOAD INCREMENT WITH THE DIAL GAUGE(S).

DESIGN LOAD (DL):

- LOADING ON THE BAR SHALL BE APPLIED BASED ON THE DESIGN LOAD AS DETERMINED BY FHWA PUBLICATION NHI 05-039, MICROPILE DESIGN AND CONSTRUCTION.
- DESIGN BOND STRENGTH FOR THIS PROJECT IS 615 LB/FT OF BOND.
- THE DESIGN LOAD (DL) IS DETERMINED BY MULTIPLYING THE DESIGN BOND VALUES BY THE BOND LENGTH OF MICROPILE. THE BOND LENGTH FOR TESTING SHOULD BE AT LEAST 10-FT.

TESTING OF MICROPILES:

- PROOF TESTING WILL BE PERFORMED ON 5% OF PRODUCTION MICROPILES. LOADING WILL BE APPLIED IN TENSION.
- A MINIMUM 48-HOUR NOTICE WILL BE PROVIDED TO THE CITY'S REPRESENTATIVES PROVIDED THEY WISH TO OBSERVE MICROPILE TESTING AT THE SITE.
- TESTS SHALL OCCUR IN LOCATIONS DETERMINED BY GSI FIELD PERSONNEL ON SITE.
- THE ALIGNMENT LOAD (AL) SHALL BE APPLIED TO ALIGN THE TESTING APPARATUS. DIAL GAUGES FOR MEASURING THE MOVEMENT OF THE TEST NAIL SHALL BE SET TO "ZERO" AFTER THE ALIGNMENT LOAD HAS BEEN APPLIED.

LOADING SCHEDULE FOR PROOF TEST

LOADING	LOAD	HOLD TIME
AL	0.025 DL MAX	2.5 MINUTES
LOAD CYCLE	0.30 DL	2.5 MINUTES
"	0.45 DL	2.5 MINUTES
"	0.60 DL	2.5 MINUTES
"	0.75 DL	2.5 MINUTES
"	0.90 DL	2.5 MINUTES
"	1.00 DL	2.5 MINUTES
"	1.15 DL	2.5 MINUTES
HOLD 1.30 DL ABOVE FOR 10 MINUTES WHILE RECORDING MOVEMENT AT 1, 2, 3, 4, 5, 6, AND 10 MINUTES. IF TOTAL MOVEMENT MEASURED DURING LOAD EXCEEDS 0.04 INCHES BETWEEN THE 1 AND 10 MINUTE AVERAGE READINGS THEN THE LOAD SHOULD BE HELD ON MICROPILE FOR AN ADDITIONAL 50 MINUTES, RECORDING MOVEMENT AT 20, 30, 40, 50, AND 60 MINUTES.		
LOAD CYCLE	1.45 DL	2.5 MINUTES
"	1.60 DL	2.5 MINUTE
UNLOAD CYCLE	1.30 DL	4 MINUTES
"	1.00 DL	4 MINUTES
"	0.75 DL	4 MINUTES
"	0.50 DL	4 MINUTES
"	0.25 DL	4 MINUTES
AL	0.025 DL MAX	4 MINUTES

MICROPILE TEST ACCEPTANCE CRITERIA:

- THE SLOPE OF THE LOAD VERSUS DISPLACEMENT CURVE IS LESS THAN OR EQUAL TO 0.025 IN/KIP AT 2.00 DL.
- THE TOTAL MOVEMENT AT 1.3 DL (CREEP) DOES NOT EXCEED 0.04 INCHES BETWEEN 1 AND 10 MINUTE READINGS, OR THE TOTAL MOVEMENT DOES NOT EXCEED 0.08 INCHES BETWEEN 6 AND 60 MINUTE READINGS.

C:\Users\jacob@gsi.com\Desktop\Projects\210487CA01 - Las Brisas Condominiums\Drawings\210487CA01-C-08.dwg, 10/20/21 4:11 PM

SHEET REVISIONS		
DATE	DESCRIPTION	NO
09/01/21	ISSUED FOR REVIEW	IFR
10/20/21	ISSUED FOR PERMIT	IFP

PROJECT NAME: LAS BRISAS CONDOMINIUMS				
SHEET TITLE: MICROPILE TESTING DETAILS				
DRAWN BY: MAC	CHECKED BY: JDR	DATE: 10/20/21	PROJECT NUMBER: 210487CA01	SHEET C-08

Phone: 855.579.0536 | Fax: 970.245.7737
www.geostabilization.com



THIS DRAWING IS FURNISHED SOLELY FOR THE USE OF OR IN CONNECTION WITH THIS PROJECT AND THE PROPRIETARY INFORMATION SHOWN HEREON IS NOT TO BE TRANSMITTED TO ANY OTHER ORGANIZATION WITHOUT SPECIFIC AUTHORIZATION BY GEOSTABILIZATION INTERNATIONAL (GSI). THE DESIGN IS ONLY VALID IF CONSTRUCTED AND SUPERVISED BY GSI OR ITS AUTHORIZED SUBCONTRACTOR.

MICROPILE ID	DATE		EMBEDMENT LENGTH (ft)	
	DRILLED	GROUTED	SOIL	ROCK
1				
2				
3				
4				
5				
6				
7				
8				
9				
10				
11				
12				
13				
14				
15				
16				
17				
18				
19				
20				
21				
22				
23				
24				
25				
26				
27				
28				
29				
30				
31				
32				
33				
34				
35				
36				
37				
38				
39				
40				
41				
42				
43				
44				
45				
46				
47				

MICROPILE ID	DATE		EMBEDMENT LENGTH (ft)	
	DRILLED	GROUTED	SOIL	ROCK
48				

MUD BALANCE READINGS	
DATE	READINGS
	(1.75-1.84, TYP. FOR GSI'S 5-BAG MIX, SEE SHEET C-03 FOR FURTHER DETAILS)

SHEET REVISIONS

DATE	DESCRIPTION	NO
09/01/21	ISSUED FOR REVIEW	IFR
10/20/21	ISSUED FOR PERMIT	IFP

PROJECT NAME:
LAS BRISAS CONDOMINIUMS

SHEET TITLE:
DRILL LOGS

THIS DRAWING IS FURNISHED SOLELY FOR THE USE OF OR IN CONNECTION WITH THIS PROJECT AND THE PROPRIETARY INFORMATION SHOWN HEREON IS NOT TO BE TRANSMITTED TO ANY OTHER ORGANIZATION WITHOUT SPECIFIC AUTHORIZATION BY GEOSTABILIZATION INTERNATIONAL (GSI). THE DESIGN IS ONLY VALID IF CONSTRUCTED AND SUPERVISED BY GSI OR ITS AUTHORIZED SUBCONTRACTOR.

DRAWN BY: MAC	CHECKED BY: JDR	DATE: 10/20/21	PROJECT NUMBER: 210487CA01	SHEET: C-13
------------------	--------------------	-------------------	-------------------------------	----------------



Phone: 855.579.0536 | Fax: 970.245.7737
www.geostabilization.com



C:\Users\kloster\OneDrive\Documents\Projects\210487CA01 - Las Brisas Condominiums\BIM\Drawings\210487CA01-CDT.dwg - 10/20/21 4:11 PM

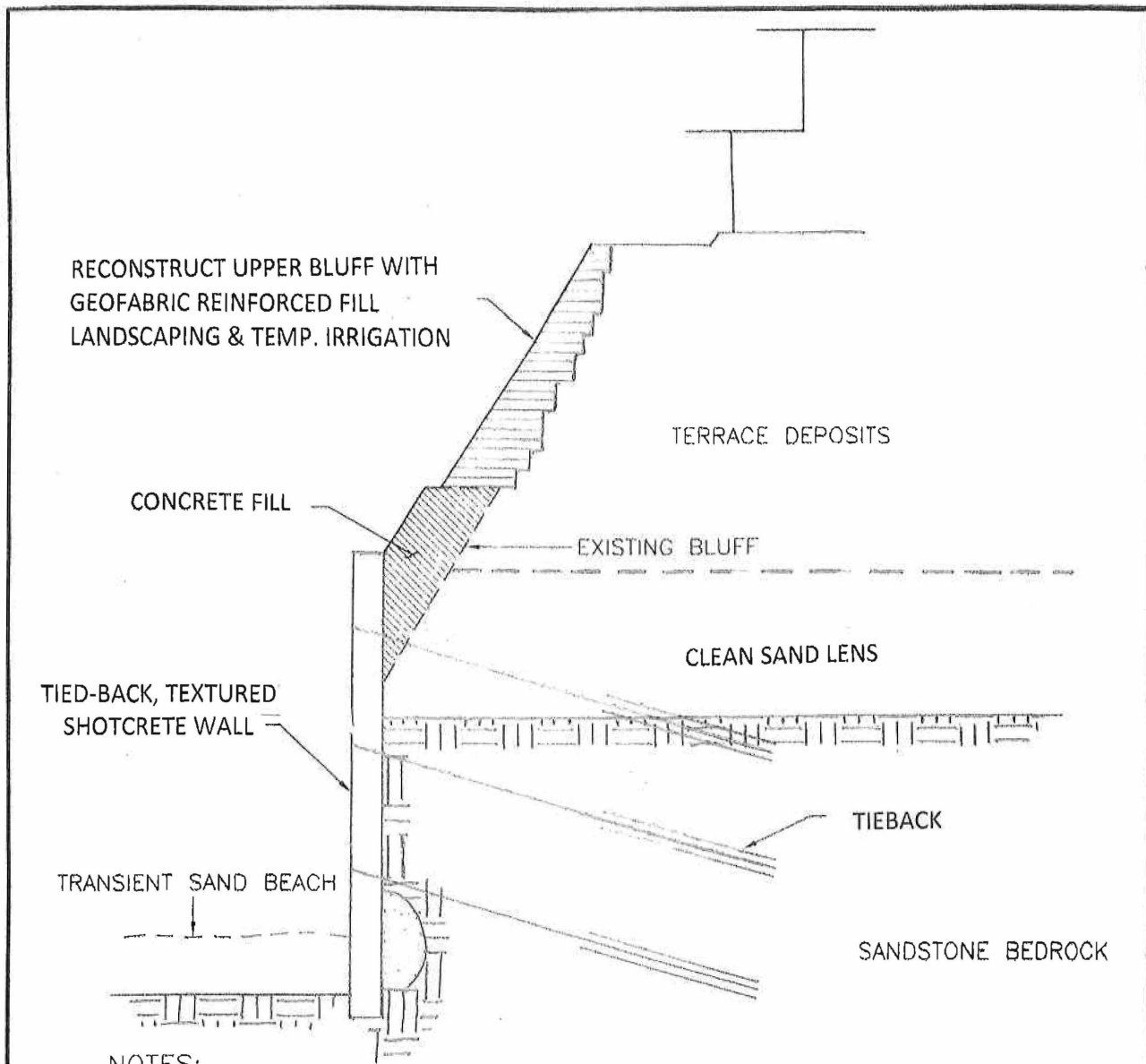

NOTES:

1. FACTOR OF SAFETY NEAR 1.0
2. GEOTECHNICAL REPORT
3. STRUCTURAL CALCULATIONS
4. LOCATED AS FAR LANDWARD AS POSSIBLE
5. MINIMIZE ALTERATION OF BLUFF-FACE OR MIMIC EXISTING.
6. INCLUDE DETAILED METHODOLOGY FOR MONITORING AND MAINTENANCE OVER THE LIFE OF THE DEVICE.
7. MINIMIZE THE NEED FOR ANY MAINTENANCE THAT NECESSITATES ADDITIONAL SEAWARD ENCROACMENT OF THE DEVICE.
8. BLUFF FACE TO HAVE "NATURAL COLOR AND TEXTURE" (SBMC 17.62)

Preferred Solution - Seawall and Upper Bluff Repair

City of Solana Beach

CCC - Approved LUP, February 2013

FIGURE NO. **3**

RECONSTRUCT UPPER BLUFF WITH
GEOFABRIC REINFORCED FILL

LANDSCAPE & TEMPORARY
IRRIGATION

CONCRETE FILL

EXISTING BLUFF/EXISTING
SEAWALL/INFILL

TRANSIENT SAND BEACH

TERRACE DEPOSITS

EXISTING BLUFF

CLEAN SAND LENS

SANDSTONE BEDROCK

NOTES:

1. FACTOR OF SAFETY NEAR 1.0
2. GEOTECHNICAL REPORT
3. STRUCTURAL CALCULATIONS
4. LOCATED AS FAR LANDWARD AS POSSIBLE
5. MINIMIZE ALTERATION OF BLUFF-FACE OR MIMIC EXISTING.
6. INCLUDE DETAILED METHODOLOGY FOR MONITORING AND MAINTENANCE OVER THE LIFE OF THE DEVICE.
7. MINIMIZE THE NEED FOR ANY MAINTENANCE THAT NECESSITATES ADDITIONAL SEAWARD ENCROACHMENT OF THE DEVICE.
8. BLUFF FACE TO HAVE "NATURAL COLOR AND TEXTURE" (SBMC 17.62)

Preferred Solution - Upper Bluff Repair

City of Solana Beach

CCC - Approved LUP, February 2013

FIGURE NO.

4

RECEIVED

DEC 21 2020

Planning-Comm Dev Dept
City of Solana Beach

HYDROSEED MIX

SCIENTIFIC OR PRODUCT NAME	COMMON NAME	RATE/ACRE	P.L.S.	SEEDS/LB.
BINDER	AZTEC™ OR APPROVED EQUAL	250 LBS.		
FERTILIZER	18-18-18	300 LBS.		
MULCH	VIRGIN WOOD FIBER	3000 LBS.		
ABRONIA VILLOSA	SAND VERBENA	1 LBS.	24%	68,000
ARTEMISIA CALIFORNIA	COASTAL SAGEBRUSH	3 LBS.	9%	55,000,000
CAMISSONIA CHEIRANTHIFOLIA SSP. SUFFRUTICOSA	SUN CUP (BEACH EVENING PRIMOSE)	1/2 LBS	72	4,000.00
ENCELIA CALIFORNIA	CALIFORNIA ENCELIA	8 LB.	24%	175,000
ERIOGONUM FASCICULATUM	CALIFORNIA BUCKWHEAT	20 LBS.	7%	450,000
LASTHENIA CALIFORNIA	DWARF GOLDFIELDS	1-1/2 LBS.	0.30%	3,250,000
LASTHENIA GLABRA	GOLDFIELDS	1-1/2 LBS.	77%	1,200,000
LUPINUS BICOLOR	PYGMY-LEAFED LUPINE	5 LBS.	78	115,000
MALOSMA LAURINA	LAUREL SUMAC	3 LBS.	57%	27,000
MIMULUS PUNICEUS	MONKEY FLOWER	1-1/2 LBS.	1%	12,000,000
YUCCA WHIPPLEI	OUR LORD'S CANDLE	3 LBS.	58%	100,000
SARYON™		6 GALS.		
SUPERTHRIVE™		20Z./100 GALS OF HYDROSEED SLURF		
MYCORRHIZAL INOCULUM, GLOMIS INTRARADICES		40 OZ.		

ATTACHMENT 4

ATTACHMENT "D"

ALTERNATIVES ANALYSIS

The proposed project proposed to extend a lateral retention wall from the southern terminus of the existing lower coastal bluff seawall to the top of the failed bluff. The project would also propose reconstruction of a relatively small area of failed mid-to-upper bluff below Las Brisas Condominiums utilizing geogrid / soil, and applying hydroseed consisting of drought-tolerant, salt-resistant native plant species. The alternatives to this project are limited and determined to be infeasible. They are addressed below.

ALTERNATIVE #1: No Project

A No Project alternative would allow a significant failure that has already reached the top of the coastal bluff to continue to extend landward toward the residential structure. Based on the existing slope stability evaluation for the project site, a No Project alternative would result in the very near future loss of the public pedestrian easement that extend from Fletcher Cove south across the rear yard (adjacent to top of bluff) of Las Brisas Condominiums. Emergency public agency vehicle access also served by this easement will be lost. Due to the significant of the ongoing failure, this access has already been temporarily closed by the City of Solana Beach. Further, it the access has already been impacted by the failure at the southern property line of Las Brisas Condominiums.

A No Project Alternative that allows the failure to continue unimpeded would also result in the likely near future impact to the southwestern residential building on the Las Brisas site. The geotechnical / factor of safety evaluation for this building notes that a single additional event failure at the top of bluff could place the building under imminent threat of damage.

Base on this analysis a No Project Alternative is not a viable response to the existing, and ongoing failure conditions at this site.

ALTERNATIVE #2: Placement of a below-grade caisson/grade beam/ tieback system set back from the top of bluff, extending north from the southerly boundary for a span of +/- 25', and extending east along the southerly boundary for a span of +/- 16'.

This alternative would acknowledge that the failure will be allowed to continue upslope until such time has it exposes the caisson system. When that event occurs, the caisson system would receive an additional row of tiebacks and a sculpted and color-treated shotcrete wall covering.

Alternative #2 would provide sufficient protection to the southwesterly residential building on the Las Brisas site, but it would result in the total loss of the existing public access easement that was required as a condition of the complex's initial approval. It would also result in the continuation of mid-to upper bluff failure below the condominium units and would therefore likely need to be extended further to the north as the mid-to-upper bluff continued to fail in that direction.

Finally, as Alternative #2 would ultimately result in an exposed upper bluff wall, it would be in conflict with the City's Preferred Bluff Retention Device Standards.

Therefore, while Alternative #2 could be found viable from an engineering perspective, it was determined to be unacceptable as a project solution.

ALTERNATIVE #3: Extension of the Existing Lower Coastal Bluff Seawall Approximately 40' to the south and reconstruction of the entire mid-to-upper bluff failure that exists at this time.

As the existing and continuing failure was initiated to the north of the Las Brisas southern property line (south of the terminus of the Las Brisas seawall), this would require the participation of a neighboring condominium association that owns the property south of Las Brisas. The residential condominium units located at the top of bluff above this 40' wall extension area are setback approximately 120' from the top of bluff. Therefore, they are not threatened by the bluff failure, and the California Coastal Commission would not be likely to approve coastal bluff protection in this area. Further, a significant sea cave is located approximately 73' north of the southern terminus of the Las Brisas seawall. When sand is not on the public beach, the exposed dimensions of the sea cave are as follows: 65' wide, 34' deep and 17' high. This sea cave will ultimately fail, and such failure will extend to the top of bluff and beyond to the east. Again, no residential units would be threatened by such failure as they are setback approximately 120' from the top of bluff. However, any seawall extending north of the existing Las Brisas seawall would be significantly threatened with flanking when such a failure occurs. South of the sea cave, there is another +/- 136 lineal feet of unprotected bluff before reaching another existing seawall.

Therefore, any extension of the existing Las Brisas seawall to the south would ultimately require additional extensions, potentially totaling over 200 feet in length. This domino-development would not be protecting existing residences. The likelihood of the property owner to the north of Las Brisas seeking permits for seawalls that are not necessary per Section 30235 of the California Coastal Act is virtually nil. The likelihood of the Coastal Commission approving such unnecessary development is equally nil.

For that reason, further extension to the south of the existing Las Brisas seawall is not a viable solution to the current failure which threatens the residential building and public access easement at that property.

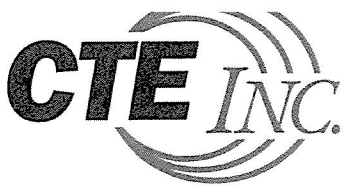

March 7, 2021

CTE Job No. 10-15983G

City of Solana Beach
Attention: Ms. Corey Andrews
635 South Highway 101
Solana Beach, California 92075
Office: (858) 720-2434

Via Email: candrews@cosb.org

Subject: Application Submittal Geotechnical Review
Las Brisas Condominiums
135 South Sierra Avenue
Solana Beach, California 92075

References: At End of Document

Ms. Andrews:

As requested, Construction Testing & Engineering, Inc. (CTE) has reviewed the provided submittal application documents referenced at the end of this letter. The purpose of our review was to assess whether the proposed project is in substantial compliance with the City of Solana Beach's (City) Local Coastal Plan (LCP) policies.

The proposed bluff retention device consists of an approximately 60-foot long shotcrete return wall supported on ten (10) 30-inch diameter caissons or drilled piers. The return wall will extend landward from an existing permitted tied-back shotcrete seawall and along the applicant's southern property line (PL). Due to the alignment of the proposed wall, from the lower seawall to the upper bluff, the wall may be considered a combined lower & upper bluff system. The applicant considers it an emergency project based on slope stability analyses provided in the referenced bluff evaluation (Terra Costa, 2020). In addition, the applicant acknowledges that the proposed wall does not comply with the City's Preferred Bluff Retention Device Standard provided in the LCP, due to the existing failure scenario not being addressed in the LCP. The applicant's proposed upper bluff stabilization measures (i.e., geogrid reinforced fill) north of the proposed return wall do appear to substantially comply with the upper bluff stabilization method depicted in LCP Preferred Solutions 3 & 4 in LCP Appendix B.

While it is noted that the submitted and reviewed report and plan appear to be very well prepared, based on CTE's review, a determination of substantial compliance with the LCP cannot be made at this time, and CTE requests the following additional information from the applicant/project consultant(s). Please also note that based on our future review of requested documents and additional information, subsequent review comments may be still be warranted.

ATTACHMENT 6

- 1) To the best of your ability, please provide the following documents alluded to in the application submittal:
 - a. Terra Costa Consulting Group (Terra Costa) April 23, 2020 letter regarding the coastal bluff referenced in the September 25, 2020 Terra Costa update bluff evaluation.
 - b. Geotechnical studies, referred to in Terra Costa's September 25, 2020 letter, that were relied upon for estimating soil strength parameters for the slope stability analyses presented in Terra Costa's September 25, 2020 letter.
 - c. Prior geotechnical documents associated with the existing seawall, including:
 - i. "Geotechnical Update Letter; Repairs to Coastal Bluff Seawall 135 South Sierra Avenue, Solana Beach, California" dated April 5, 2010 by Soil Engineering Construction, Inc.
 - ii. "Geotechnical/Geologic Evaluation Bluff Conditions, Las Brisas Condominiums" by Anthony-Taylor Consultants dated June 22, 2004
 - iii. The 2018 written monitoring report alluded to in the applicant's referenced cover letter, and other available monitoring reports.
- 2) Per the permit application, question 5, please provide a geotechnical report prepared to meet the requirements of the City and the California Coastal Commission (CCC) signed and stamped by both a Registered Civil Engineer (RCE) and Certified Engineering Geologist (CEG). A previously prepared geotechnical report associated with the previous wall construction, updated to current standards of practice and signed and stamped by a RCE and CEG, may be suitable.
- 3) Please provide structural calculations for the proposed shotcrete wall, including determination of caisson embedment depth and proposed embedment units, and any geotechnical documents relied on for geotechnical parameter inputs for the calculations.
- 4) Please provide additional slope stability analysis for a proposed-construction scenario demonstrating a 1.5 Factor of Safety for the completed project.
- 5) Please provide a site plan and geologic cross-section of the existing slope failure that depicts the underlying geology; the limits of the public access easement; the seaward side of the nearest principal structure foundational element; and verified top-of-bluff and corresponding minimum setbacks.
- 6) Please discuss current landscaping and irrigation practices at the project location. If a landscaping operation & maintenance plan is available, please submit.

- 7) Noting that the LCP defines City Infrastructure as “City owned roads and City owned utilities located therein and thereon”, please comment as to whether a bluff failure is imminent that would threaten city infrastructure and/or a principal structure with danger from erosion, per LCP Policy 4.52(a)(1). Additionally, please comment as to whether city infrastructure and/or a principal structure is more likely than not to be in danger within approximately one year, per LCP Policy 4.52(a)(2).
- 8) Please address the proposed project’s impact on the southerly neighbor, including but not limited to:
 - a. What impact will the proposed wall have on the future erosion of the remaining exposed scarp on the southerly neighbor’s property?
 - b. The proposed wall drains appear to be intended to drain from the face of the wall onto the southerly neighbor’s property. What impact will the proposed wall drains have on the future erosion of the remaining exposed scarp on the southerly neighbor’s property? Please show all drain outlets on plans.
- 9) Please indicate the proposed post-construction depth of embedment of the southerly face of the proposed shotcrete wall. Address whether this embedment depth is appropriate and/or adequate to accommodate potential erosion and scour at the wall base and potential undermining of the wall. Please address what long-term maintenance of the wall may be necessary to protect against or accommodate future erosion and potential undermining at the base of the wall.

As previously stated, based on our review of requested documents and information indicated above, additional review comments may be warranted.

We appreciate this opportunity to be of service on this project. If you have any questions regarding this report, please do not hesitate to contact the undersigned.

Respectfully submitted,

CONSTRUCTION TESTING & ENGINEERING, INC.

Dan T. Math, GE #2665
Principal Engineer

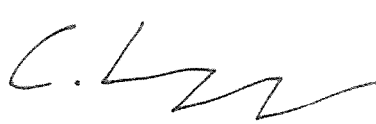

Colm J. Kenny, RCE #84406
Senior Engineer

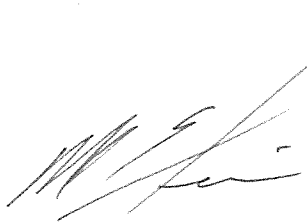

Martin E. Siem, CEG #2311
Senior Engineering Geologist



CJK/MES/DTM:cjk

REVIEWED DOCUMENTS:

City of Solana Beach Local Coastal Plan
Adopted February 27th, 2013, As Amended November 2018

Application for Conditional Use Permit (Cover Letter)
Coastal Bluff Failure Repair
Las Brisas Condominiums
Issued by The Trettin Company, dated December 16, 2020

Bluff Retention Device Conditional Use Permit Application
Las Brisas Condominiums
135 South Sierra Avenue
Solana Beach, California 92075
Dated December 16, 2020

Coastal Bluff Evaluation/Project Recommendations
Las Brisas Condominiums
135 South Sierra Avenue
Solana Beach, California
Terra Costa Consulting Group Project No. 1848-02, dated September 25, 2020

Plans for Las Brisas Condominiums Bluff Stabilization (5 Sheets)
Prepared by Terra Costa Consulting Group
Dated September 28, 2020



Construction Testing & Engineering, Inc.

Inspection | Testing | Geotechnical | Environmental & Construction Engineering | Civil Engineering | Surveying

December 22, 2021

CTE Job No. 10-15983G

City of Solana Beach
Attention: Ms. Corey Andrews
635 South Highway 101
Solana Beach, California 92075
Office: (858) 720-2434

Via Email: candrews@cosb.org

Subject: Application Submittal Second Geotechnical Review
Las Brisas Condominiums
135 South Sierra Avenue
Solana Beach, California 92075

References: At End of Document

Ms. Andrews:

As requested, Construction Testing & Engineering, Inc. (CTE) has reviewed the provided submittal application documents referenced at the end of this letter. The purpose of our review was to assess whether the proposed project is in substantial compliance with the City of Solana Beach's (City) Local Coastal Plan (LCP) policies. This is the second submittal review.

Based on CTE's review, the applicant has adequately addressed CTE's previous review comments. CTE notes that the applicant's submitted slope stability analysis indicates that "... within the last approximately 8-months... observed and continuing deterioration of the lower bluff and over-steepened conditions of the mid- and upper bluff, create a real and imminent threat to Building 3, and to the public access corridor for the designated public open space at the Surfsong project. This same access corridor also functions and [sic] the Las Brisas fire access road, providing fire truck access to both Building 3 and portions of Building 1. As such, the observed failures within the bluff along and west and below Building 3, have a real potential to threaten the health and safety of the beach going and access corridor using public, as well as threatening the stability of Building 3."

CTE believes that Building 3 would be considered a "principal structure" per the LCP.

We appreciate this opportunity to be of service on this project. If you have any questions regarding this report, please do not hesitate to contact the undersigned.

Respectfully submitted,

CONSTRUCTION TESTING & ENGINEERING, INC.



Dan T. Math, GE #2665
Principal Engineer



Colm J. Kenny, RCE #84406
Senior Engineer



CJK/DTM:cjk

REVIEWED DOCUMENTS:

Geotechnical Update and Response to Third-Party Geotechnical Review
Las Brisas Condominiums Bluff Stabilization
135 South Sierra Avenue
Solana Beach, California 92075
CUP 20-004
GeoSoils, Inc. W.O. 8157-A-SC, dated October 22, 2021

Las Brisas Condominiums Bluff Stabilization Engineering Design Submittal
Prepared by GeoStabilization International, dated 15, 2021

Response to CTE Review of CUP 20-004; Modification to a CUP for Las Brisas Condominiums
Provided by The Trettin Company, dated November 1, 2021

Application Submittal Geotechnical Review
Las Brisas Condominiums
135 South Sierra Avenue
Solana Beach, California 92075
CTE Job No. 10-15983G, dated March 7, 2021

City of Solana Beach Local Coastal Plan
Adopted February 27th, 2013, As Amended November 2018

Geotechnical/Geologic Evaluation
Bluff Conditions
Las Brisas Condominiums
135 South Sierra Avenue
Solana Beach, California 92076
Anthony-Taylor Consultants Project No. 03-2283, dated June 22, 2004



Geotechnical Engineering
Coastal Engineering
Maritime Engineering

Project No. 1848-02
September 25, 2020

Ms. Renee Resler, Chair
Mr. Brian Caine, Member
LAS BRISAS HOA
135 S Sierra Avenue #36
Solana Beach, California 92075

COASTAL BLUFF EVALUATION/PROJECT RECOMMENDATIONS
LAS BRISAS CONDOMINIUMS
135 SOUTH SIERRA AVENUE
SOLANA BEACH, CALIFORNIA

Dear Ms. Resler and Mr. Caine:

TerraCosta Consulting Group, Inc. (TerraCosta) is pleased to present this letter concerning our evaluation of coastal bluff stability in response to the significant and ongoing coastal bluff failure at the southern end of the Las Brisas condominium complex located at 135 South Sierra Avenue in Solana Beach, California. This letter should be considered an update to our April 23, 2020, letter regarding the subject coastal bluff.

To date, we have performed several site inspections, the first being to map the approximate limits of the slope failure using the topographic base map for the subject property prepared by Pasco Laret Suiter on October 14, 2019. As part of our field mapping, we reconstructed the approximate contours to reflect the failure limits as they existed during our initial April 16, 2020, site inspection. The approximate geometry of the slope failure during our field mapping is presented on Figure 1.

Slope stability analyses were performed on two representative cross sections to determine stability of the coastal bluff for the existing failure conditions. The locations of the cross sections are presented on Figure 1. Analyses were performed using the slope stability computer program *GSTABL7*. *GSTABL7* is a 2D limit equilibrium slope stability program with a variety of options for external loads, along with various external restraints. Strength parameters used in our analyses were based on data in our files from

other geotechnical studies in Solana Beach. Summary outputs of the analyses are presented on Figure 2 through 5.

As indicated on the attached figures, the minimum computed static factor of safety for the existing conditions was as low as 1.021 in the area of the public easement/public agency vehicle access. This area is under a high threat of failure in the near future.

The computed static factors of safety for failure terminating at the southwest corner of the existing building were as low as 1.231. This existing factor of safety is significantly below the required California Building Code minimum of 1.5. Although the southwest corner of the existing building is not imminently threatened, it could potentially reach that threshold following a single event failure which causes the bluff, down to the area of the clean sand lens, to retreat eastward by several additional feet. Based on the existing bluff failure, which extends from the clean sand lens to the top of bluff, such a single event failure into the rear yard/public easement area could occur at any time.

Based on public agency permit requirements that Las Brisas provide and maintain a dedicated public access and public vehicle access in the area of the ongoing failure, and with consideration provided to the near-imminent threat to the residential structure, it is our recommendation that Las Brisas initiate the required permitting actions to construct a caisson/grade beam/tieback lateral wall that would extend from the southern terminus of the existing permitted seawall to the top-of-bluff. The engineering design we are submitting for your review would be sufficient to return a minimum 1.5 factor of safety to the threatened public access areas and to the existing residential structure on the Las Brisas property. Further, it will protect the existing, permitted lower coastal bluff seawall from being flanked and will prevent further loss of the mid to upper coastal bluff at Las Brisas.

We note that the time to obtain necessary discretionary permits for a project is likely in the range of 18 months. Therefore, we recommend that the site be consistently monitored during the permit process. Should further significant failure occur during that period, a reevaluation of the potential escalation of the threat to the residential structure should be performed immediately. Under such circumstances, a determination should be provided to determine if expedited or emergency permitting should be implemented.



We appreciate the opportunity to be of service and trust this material meets your current needs. We look forward to working with you and your permit agent in securing a full solution to the significant failure occurring on your coastal bluff. If you have any questions or require additional information, please give us a call.

Very truly yours,

TERRACOSTA CONSULTING GROUP, INC.

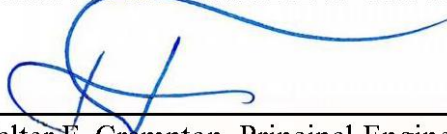

Walter F. Crampton, Principal Engineer
R.C.E. 23792, R.G.E. 245

WFC/jg
Attachments





SCALE: 1"=20'

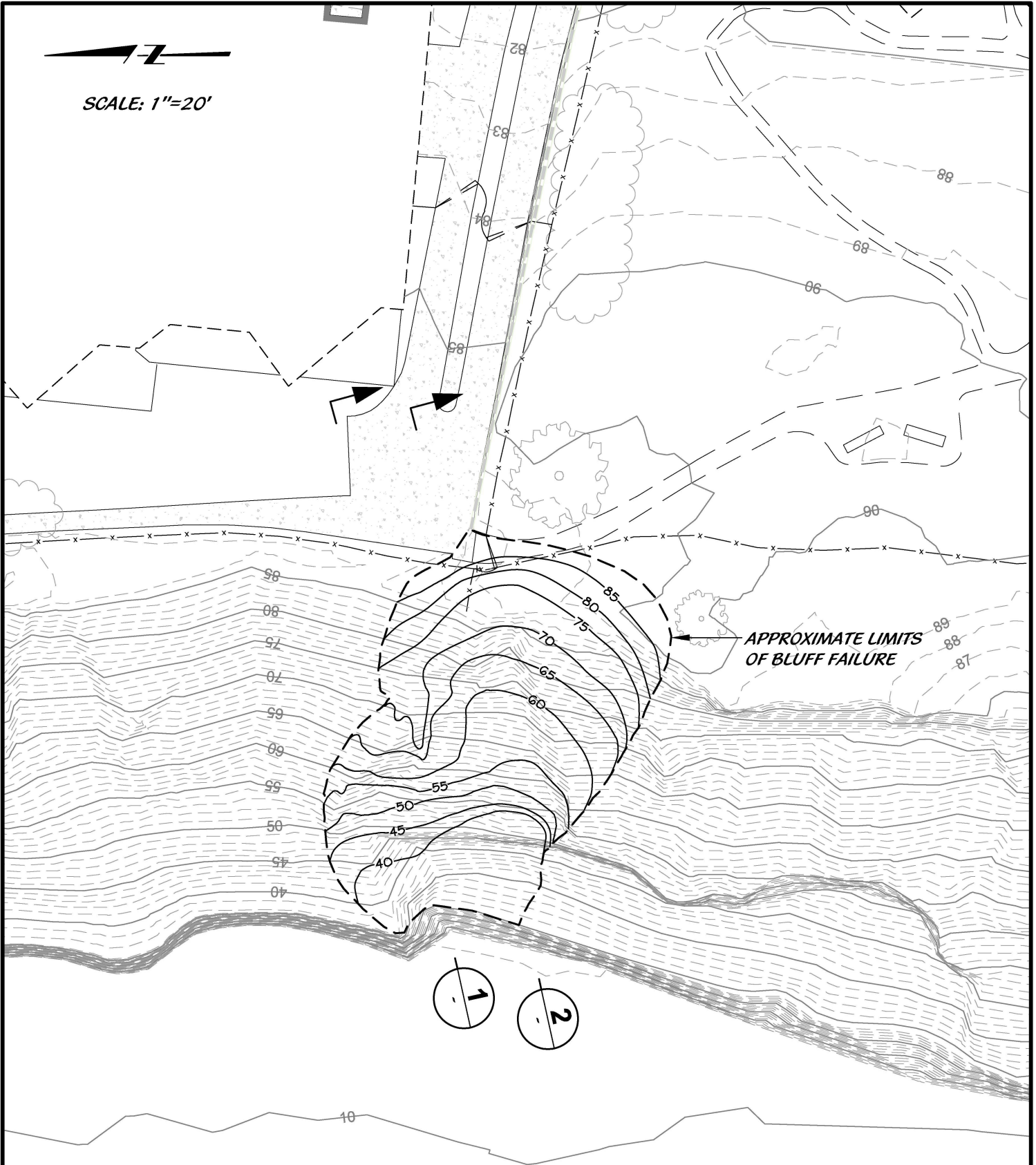

TERRACOSTA CONSULTING GROUP
ENGINEERS AND GEOLOGISTS
3890 MURPHY CANYON ROAD, SUITE 200
SAN DIEGO, CA 92123 (858) 573-6900

PROJECT NAME
LAS BRISAS BLUFF FAILURE

FIGURE NUMBER
1

PROJECT NUMBER
1848-01

**STABILITY SECTION
SITE PLAN**

Las Brisas Condominiums Stability Section 1

s:\matt m\las brisas\stability section 1.pl2 Run By: Username 4/21/2020 10:18AM

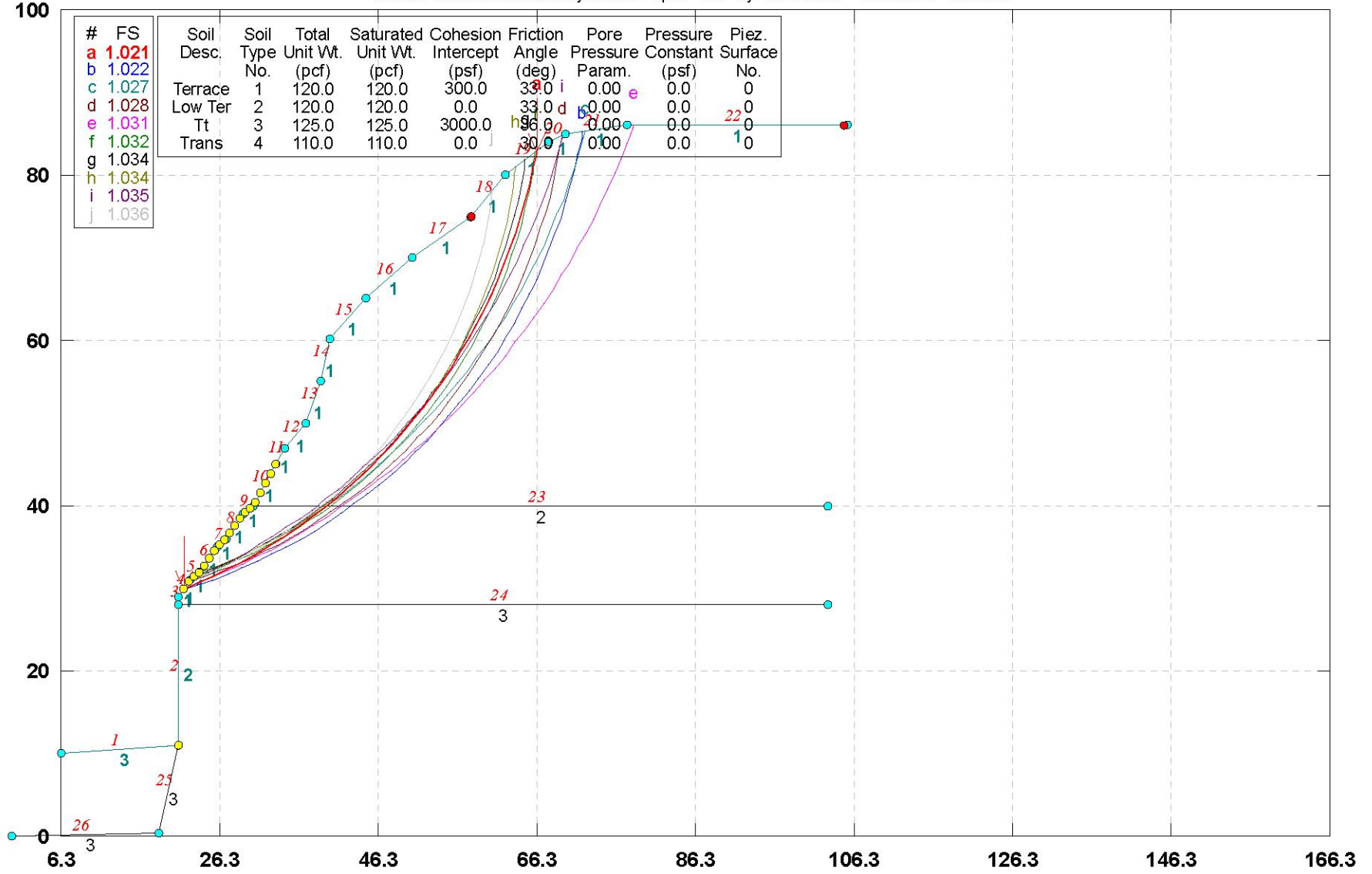

GSTABL7 v.2 FSmin=1.021
Safety Factors Are Calculated By The Modified Bishop Method

FIGURE 2

Las Brisas Condominiums Stability Section 2

s:\matt m\las brisas\stability section 2.pl2 Run By: Username 4/21/2020 10:16AM

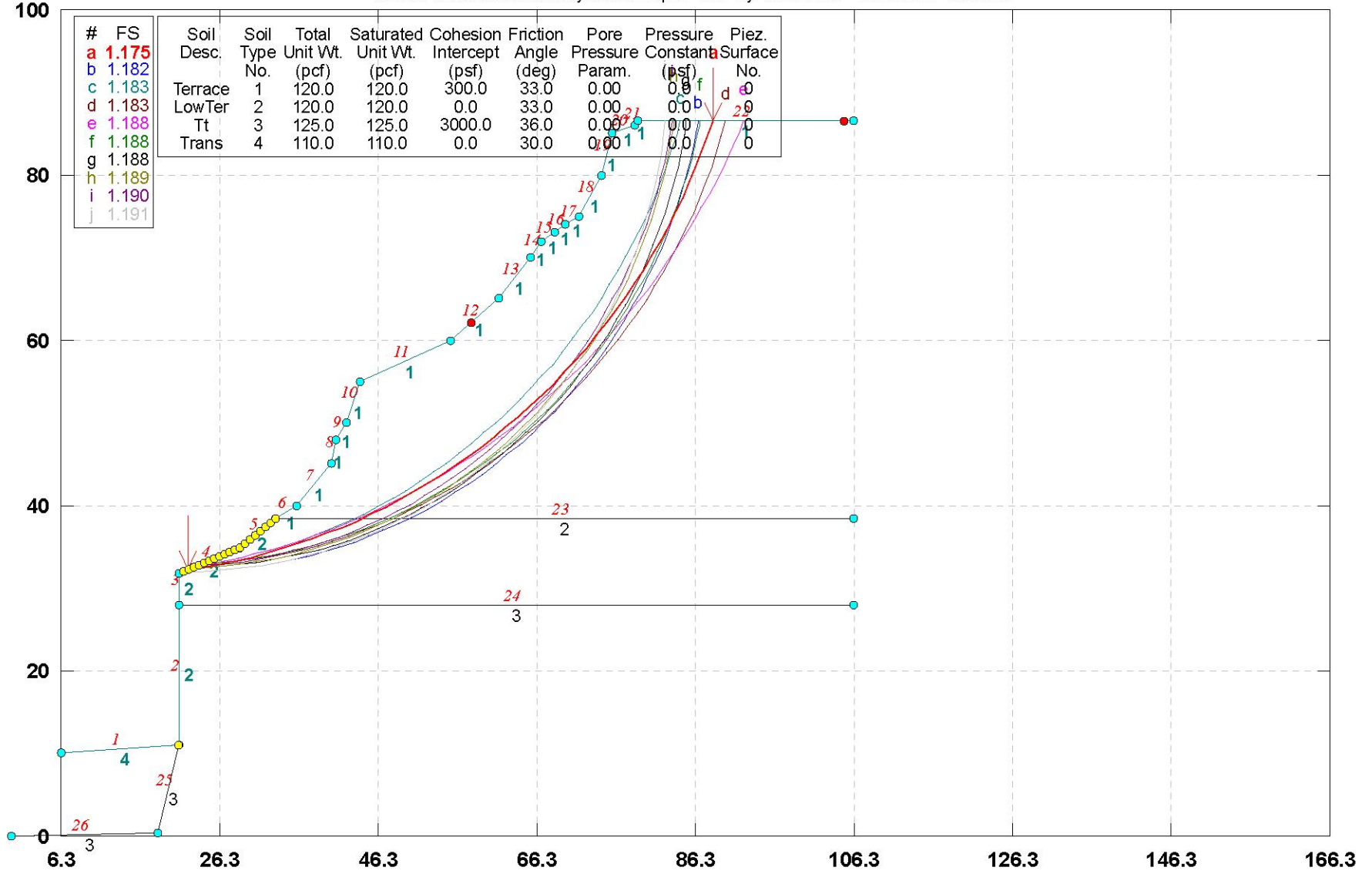

GSTABL7 v.2 FSmin=1.175
Safety Factors Are Calculated By The Modified Bishop Method

FIGURE 3

Las Brisas Condominiums Stability Section 1

s:\matt m\las brisas\stability section 1, terminate at building.pl2 Run By: Userame 4/22/2020 12:51PM

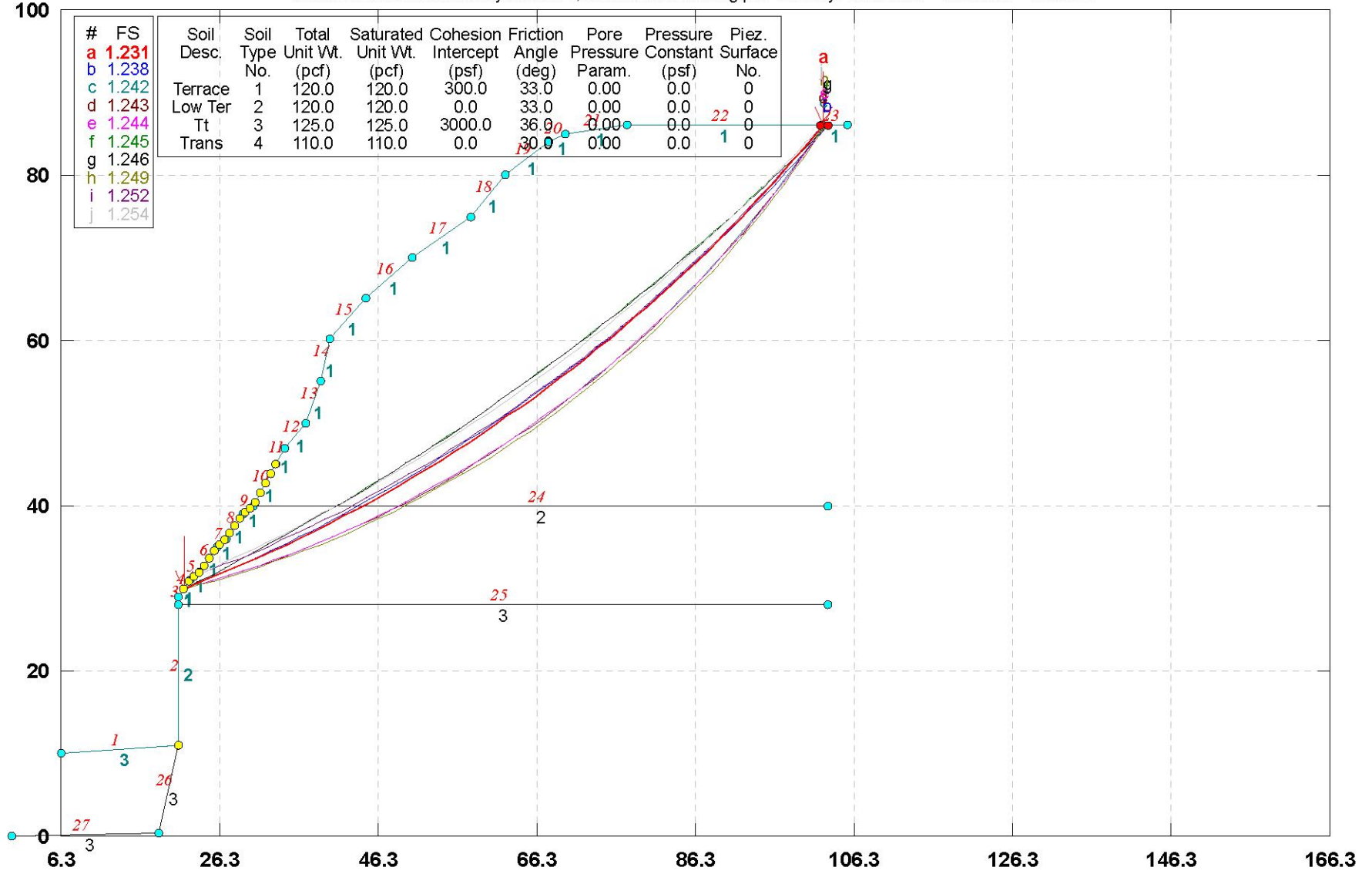

GSTABL7 v.2 FSmin=1.231
Safety Factors Are Calculated By The Modified Bishop Method

FIGURE 4

Las Brisas Condominiums Stability Section 2

s:\matt m\las brisas\stability section 2, terminate at building.pl2 Run By: Userame 4/22/2020 12:56PM

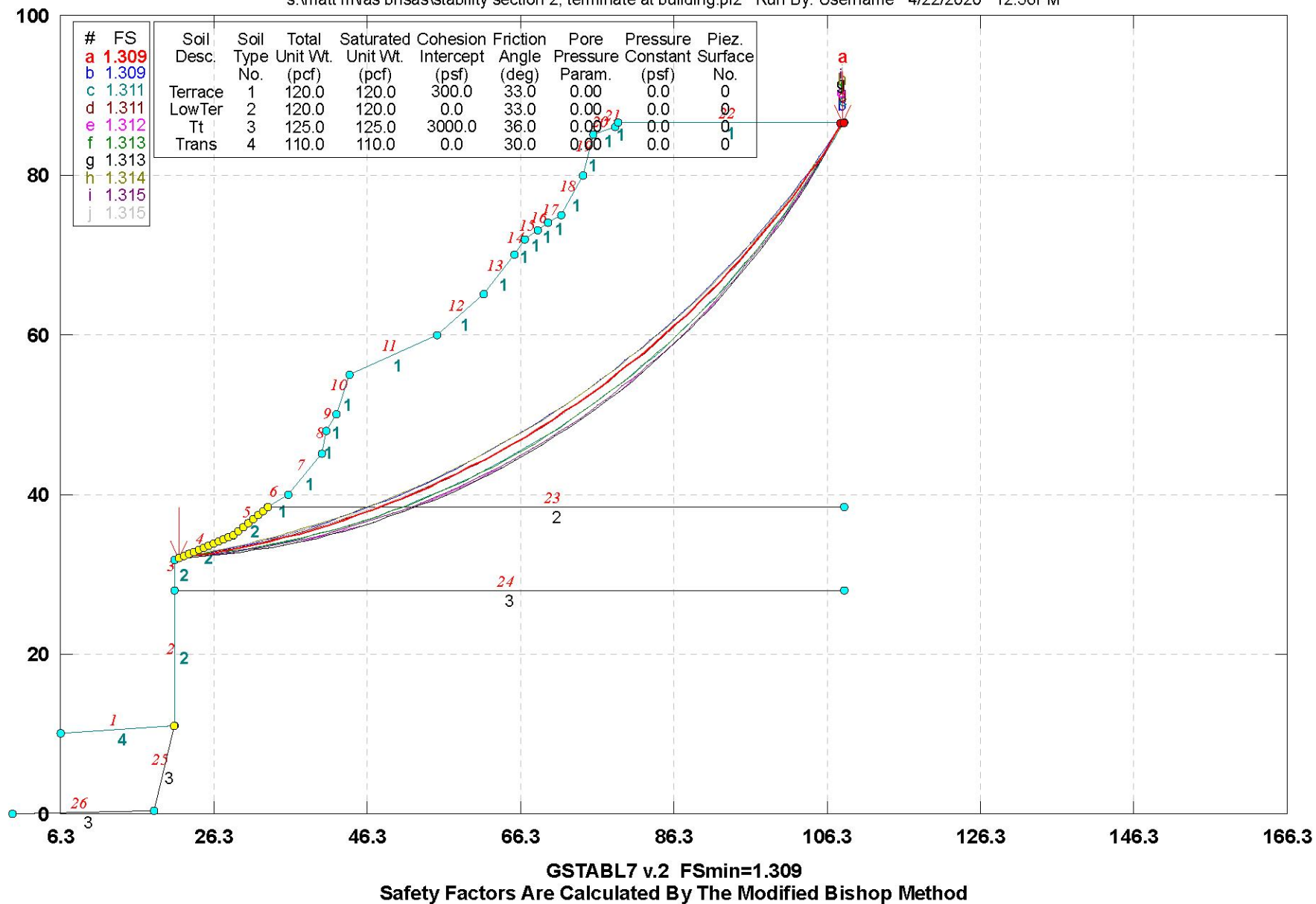

FIGURE 5

Las Brisas Condominiums Bluff Stabilization Engineering Design Submittal

2021



Regional Address:
4475 E. 74th Avenue
Commerce City, CO. 80022
Phone: 855.579.0536
Fax: 970.245.7737
www.geostabilization.com

ATTACHMENT 8

October 15, 2021

To: Ms. Renee Resler

Subject: DESIGN-BUILD DOWNSLOPE MICROPILE CUTOFF WALL

GeoStabilization International (GSI®) is pleased to present the following Engineering Design Submittal for the permanent micropile cutoff wall proposed for the Las Brisas Condominiums Site (Site) at 135 South Sierra Avenue Solana Beach, CA 92075.

This submittal consists of information pertaining to the design and construction of the proposed cutoff wall that will retain the backfill material planned on the north side of the wall. The micropiles will be embedded a minimum of five feet into the Torrey Sandstone Formation underlying the site. Micropile stickup above existing grade will be encapsulated with reinforced structural shotcrete, which will provide a system that achieves the Factor of Safety values required for the project.

Information in this submittal was developed based on, but not limited to, the following:

- *Geotechnical/Geologic Evaluation Bluff Conditions*, prepared by Anthony-Taylor Consultants, dated June 22, 2004.
- *Las Brisas Condominiums Bluff Stabilization Draft Plans*, prepared by Terracosta Consulting Group Engineers and Geologists, September 28, 2020.
- Multiple field reconnaissance completed by GSI Project Development Geologist Josh Wagner, Deputy Operations Manager, Spike Priestly, and Regional Engineer Jody Robinson.
 - Three-dimensional drone model developed from drone survey performed during site reconnaissance.

Our opinions and statements regarding this project shall remain confidential and shall not be shared with other parties without the express written consent of GSI®.

Sincerely,

GeoStabilization International®



Cameron Lobato, P.E.
Senior Vice President

Jody Robinson, P.E.
Regional Engineer

Table of Contents

Micropile Cutoff Wall	3
Project Description.....	3
Design Requirements	4
Micropile Cutoff Wall Elements and Strengths.....	4
Slope Stability Analyses	5
Design Material Properties	6
Design Structural Properties.....	7
Corrosion Potential	8
Structural Elements – Material Properties	8
Appendix A - Construction Sequence.....	A-1
Construction Sequence	A-1
Appendix B - Design Analyses Output	B-1
Appendix C - Calculations	C-1
Facing Calculations	C-1
Tensile and Compression Capacity	C-4
Appendix D - Material Properties	D-1
Self-Drilling SuperNails™	D-1
Facing Reinforcement.....	D-1
Drain Strip.....	D-1
Shotcrete	D-1
Grout.....	D-2
Appendix E - Micropile Testing.....	E-1
Testing Procedure and Equipment	E-2
Testing on Micropiles.....	E-2
Appendix F - Construction Details.....	F-1

Micropile Cutoff Wall

Project Description

The subject property is known as the Las Brisas Condominiums, located at 135 South Sierra Avenue, San Diego County, City of Solana Beach, California. The Condominiums consist of three separate residential structures, comprising multi-story, multi-unit masonry structures founded on shallow foundations.

The upper bluff face within the vicinity of the most westerly building at the site (identified as Building 3 in the project geotechnical/geological evaluation) has been susceptible to significant erosion and scouring. As such, a section of the upper bluff has failed, leading to significant risk to Building 3 and a recorded easement for public agency vehicles, including emergency vehicles.

GSI's scope of work includes construction of a micropile cutoff wall that will retain the exposed failed bluff and mitigate against damages associated with migration of the existing scarp towards the north and east of the exposed bluff. The cutoff wall will be comprised of up to 65-foot long micropiles that run downslope, approximately along the existing property line. This design is a value engineered (VE) alternative to the original drilled shaft cutoff wall concept developed by TerraCosta. Micropiles will be spaced 18 inches on center and depths will vary to ensure up to 5-foot embedment into the Torrey Sandstone Formation underlying the site; thereby, mitigating against possible undermining of the repair over time. In general, design pile embedment lengths vary between approximately 8 and 65 feet. Conceptually, the final aesthetics of the repair will remain identical to the original concept proposed by TerraCosta, with a sculpted and stained shotcrete facing.

On the north side of the shotcrete facing, a reinforced soil slope (RSS) will be constructed to occupy the existing void on the Las Brisas property. The RSS will comprise woven geotextile grids to construct the wall face in alignment with surrounding grades to the north. The end of the grids will be pinned to the slope with hand-driven mechanical anchors every third lift to accommodate sliding stability of the RSS (i.e., mitigate against the RSS sliding downslope). The remaining intermediate grid layers will be pinned to the slope using ground stakes. The geotextile will provide permanent erosion protection from initial construction.

All infrastructure will be built exclusively on Las Brisas HOA property; however, to construct the solutions presented herein, GSI crews (of up to six people) may need temporary access to the neighboring property to the south (Surfsong HOA). This access shall be for foot traffic only and will likely be required at various times during construction. It is not anticipated that GSI crews will pass further than 20 feet to the south of the Las Brisas - Surfsong property line. It is the sole responsibility of Las Brisas HOA to coordinate any necessary temporary access agreements prior to GSI arriving on site.

Design Requirements

The permanent micropile cutoff wall will comprise the installation of an array of hollow bar micropiles faced with reinforced shotcrete to provide confinement for the RSS proposed on the north side of the shotcrete wall. The compound global stability of the system was designed to accommodate a static factor of safety (FS) of 1.5 and a seismic FS of 1.1. We note that our system does not account for wave impact due to potential Tsunami inundation following an earthquake.

Our design accounted for a construction and vehicular at the top of the bluff. We iteratively analyzed surcharges between 250 and 3,000 pounds per square foot (psf) to analyze impact of surcharging on the global stability of the slope. The stability results in Appendix B are provided for a 3,000 psf surcharge.

Micropile Cutoff Wall Elements and Strengths

The cutoff wall consist of an array of micropiles, concrete micropile cap, reinforced shotcrete facing, and a reinforced soil slope (RSS). The micropiles will consist of 51mm domestic hollow bar steel with embedment depths up to 65 feet. We note that lengths and spacing of micropiles elements may vary depending on conditions observed at the time of construction, but the maximum spacing of micropiles will be 18 inches along the property line and each will be embedded a minimum of 5 feet into the Torrey Sandstone unit underlying the site. The micropile cap will extend 10 feet east of the bluff edge and structurally connect to the micropiles east of the bluff edge. The micropile cap will have a minimum cross-sectional width of 18 inches and depth of 12 inches. Internal steel reinforcement embedded in the micropile cap will extend west of the bluff edge to structurally tie into the proposed shotcrete wall. The nominal design thickness of the structural shotcrete facing will be 8 inches and the final lift of shotcrete applied to the wall will be sculpted and stained to match the draft design plans issued by Terracosta Consulting Group Engineers and Geologists.

The micropiles will generally be drilled vertically along the slope and installed with a nominal 4.5-inch diameter drill bit. The design tributary spacing of the micropiles will be 18 inches along the property line. The facing will consist of reinforced structural shotcrete, with two layers (one on north side of piles and one on south side of piles) of gauge 4.0 welded wire steel fabric and continuous No. 5 vertical and horizontal steel walers spaced 18 inches vertical and horizontally along the south side of the wall extents.

All steel reinforcing elements installed as part of the cutoff wall will have corrosion protection through either epoxy or galvanization, pending material availability at the start of construction. In addition, a minimum of 2 inches of cover from the atmosphere will be provided for steel elements embedded in the structural facing and micropile cap, as specified by ACI-318. Further, a minimum of 3 inches of cover from the ground will be provided for steel elements embedded in the structural facing and micropile cap, as specified by ACI-318.

The RSS will be comprised of woven geotextile reinforcement. Since the RSS fill cannot be confined at the face, the upper 12 inches of fill will be in a relatively loose condition to

construct the wall face in alignment with surrounding grades to the north. The RSS reinforcement will be PYRAMAT® 75 high performance turf reinforcement mat (HPTRM) (or equivalent, depending on material availability at the time of construction), which is a three dimensional, lofty, woven polypropylene geotextile that is specially designed for erosion control applications on steep slopes. The matrix is composed of polypropylene monofilament yarns which exhibits high interlock and reinforcement capacity with both soil and root systems. The material has a very high UV resistance making it advantageous for marine environments susceptible to high UV demands. The expected design life of the reinforcement is 75 years and is in conformance with all relevant ASTM standards as indicated on the project data sheet provided in the materials section of this submittal. Reinforcement lengths will be a minimum 4 feet and all reinforcement will extend to the exposed slope face. The grids will be pinned to the slope every third lift with hand-driven mechanical anchors. The remaining intermediate grid layers will be pinned to the slope using ground stakes. Horizontal spacing of stakes will be no less than one every six feet, or a minimum of two per lift. The target batter of the RSS will be approximately 45 degrees, which tends to line up well with the existing slope north of the proposed repair area.

The allowable tension capacity for the micropiles is approximately 33,600 pounds for static loadings conditions and 45,300 pounds for seismic loading conditions. The allowable compression capacity for the micropiles is 61,000 pounds.

Slope Stability Analyses

Overview

We completed a multiple scenario [static long-term effective stress conditions and seismic active (pseudostatic) conditions] slope stability assessment of the permanent RSS and micropile cutoff wall to analyze compound-stability of the system. The geometry of our slope stability model was developed based on the three-dimensional drone model from our site survey.

A slope stability analysis was first completed using the two-dimensional finite element analysis software PLAXIS 2D 2021. Once a baseline model was calibrated, a secondary analysis was completed using the three-dimensional finite element software PLAXIS 3D 2021. The PLAXIS program performs safety analysis to analyze slope stability and to determine a factor of safety (FS) against global failure. The FS against failure can be generalized as the ratio of forces resisting slope movement (e.g., soil strength, soil mass, etc.) and the forces driving slope movement (e.g., gravity, earth pressure, and earthquake shaking). A FS value greater than 1 and less than 1.2 indicates a condition where the slope has potential to creep over time. A FS value of 1 or less indicates a failure condition.

We analyzed stability of the proposed system, as shown in the PLAXIS output included in Appendix B. The PLAXIS model inputs are included on pages 1 through 26 in Appendix B. The PLAXIS model inputs are included on pages 27 through 33 in Appendix B. We evaluated two loading cases based on static and seismic loading conditions as follows:

- **Case 1:** Static (non-seismic) long-term (steady-state, effective stress) conditions with peak drained strength properties.
- **Case 2:** Seismic (code-based approach) conditions were analyzed with the design-level ground motion parameters indicated in the project geotechnical report issued by Terracosta. The horizontal seismic coefficient (k_h) used in our analysis was one-half of the site peak ground acceleration (PGA) or 0.22.

Approach to Soil and Rock Elements

The subsurface profile used in our modeling and analysis was based on the field and laboratory data provided in the Geotechnical Report by Terracosta, and our experience in similar soil units.

The Terrace Deposits identified at the site were modeled using the Hardening Soil small (HSsmall) constitutive model. A key benefit of the HSsmall model is that it provides an adjustable shear modulus degradation curve based on the Hardin-Drnevich relationship (Plaxis 2014). The HSsmall model includes a stress-dependent stiffness formulation, as well as shear hardening and compaction (cap) hardening in primary loading. The reference stress used to initialize stress conditions was calibrated based on available field data, typical values in the literature, and our experience in similar materials.

To analyze impact of the stress state in the Terrace Deposits on performance of the proposed stabilization elements, a loose layer of sand was modeled in the bottom 8 feet of the soil profile, immediately above the rock formation.

The overall sedimentary rock formation identified at the site was modeled using the Hoek-Brown constitutive model. A benefit of the Hoek-Brown model is that it provides a better non-linear failure criterion for the strength of rocks as opposed to the linear Mohr-Coulomb failure criterion.

The table below summarizes the estimated engineering properties for each subsurface unit at the site.

Design Material Properties

Reference Parameter	Material			
	Terrace Deposits	Loose Sand	RSS Fill	Torrey Sandstone Formation
Unit Weight (lb/ft ³)	110	105	120	120
Peak Friction Angle, ϕ' (degrees)	34	32	40	N/A
Effective Cohesion, C (lb/ft ²)	5	5	10	N/A
Reference Elastic Modulus at 50% Strain (lb/ft ²)	1.14E6	1.14E6	1.14E6	-
Reference Elastic Modulus Constrained (lb/ft ²)	1.14E6	1.14E6	1.14E6	-
Reference Elastic Modulus During Unload/Reload (lb/ft ²)	3.43E6	3.43E6	3.43E6	-
Reference Small Strain Shear Modulus (lb/ft ²)	2.55E6	2.55E6	2.55E6	-
Unconfined Compressive Strength (lb/ft ²)	-	-	-	3.65E6

Geological Strength Index (-)	-	-	-	80
Material Constant	-	-	-	17

Nominal (ultimate) bond stress values for subsurface materials were estimated based on the material types and tables in the Federal Highway Administration (FHWA) GEC Circular No.4 (1999), FHWA GEC Circular No.5 (2002), and FHWA GEC Circular No.7 (2015), as well as our experience with similar material types. In PLAXIS, a linear and material dependent bond strength was used to account for the bond reduction in the loose sand layer between the Terrace Deposits and Torrey Sandstone Formation.

- Terrace Deposits – 750 pounds per foot (lbs/ft)
- Loose Sand – 500 lbs/ft
- Torrey Sandstone Formation – 900 lbs/ft

Approach to Structural Elements

The cutoff wall consists of an array of micropiles, concrete micropile cap, reinforced shotcrete facing, and RSS.

The proposed micropiles were modelled in PLAXIS as beam elements, with axial and bending stiffness values based on the structural properties. The beam elements were modeled using our anchor pullout resistances based on the available subsurface data, and our experience in similar materials. We defined the stiffness of the embedded beams based on the elastic properties of the steel bars and ignored grout contribution by conservatively assuming a fully cracked grout condition. The reinforced shotcrete facing and micropile cap were modelled used the concrete constitutive model in PLAXIS. The model was calibrated based on a 28-day design compressive strength of 4,000 pounds per square inch (psi). The stiffness contribution from the steel reinforcing embedded in the shotcrete facing was conservatively ignored in the PLAXIS analyses. However, the reinforced shotcrete facing was designed using the ACI 318-14 code. The facing design calculations are provided in Appendix C.

The PYRAMAT® 75 woven geotextile was modelled in PLAXIS as an anisotropic elastic geogrid with in-plane (EA_1) and out-of-plane (EA_2) stiffness values based on the manufacturer’s specifications, which are listed below.

Design Structural Properties

Structural Element	Area, A (ft ²)	Moment of Inertia, Ix (ft ⁴)	In-Plane Axial Stiffness, EA ₁ (lb/ft)	Out-of-Plane Axial Stiffness, EA ₂ (lb/ft)	Nominal Moment Capacity, M _p (lb-ft)
X51	0.11	0.97E-3	63.1E6	63.1E6	6,304
PYRAMAT® 75	-	-	4,000	2,000	-

Approach to Staged Construction

The PLAXIS model had several sequential construction stages to take into consideration the effects of duration, stress history, and construction sequence on the behavior of the proposed cutoff wall. The full model sequential construction stages in our PLAXIS model are outlined below.

- Stage 1 – Generate initial at-rest (k_0) stress conditions.
- Stage 2 – Plastic nil phase to verify equilibrium of stresses.
- Stage 3 – Installation of micropile elements.
- Stage 4 – Construction of Reinforced Shotcrete Facing
- Stage 5 – Begin building up reinforced soil slope (RSS).
- Stage 6 through 34 – Continue with RSS construction until reaching top of bluff elevation.
- Stage 35 - A global stability FS calculation was performed in PLAXIS following installation of the final layer of reinforcement and fill.

PLAXIS Outputs

Results from our stability analyses are included in Appendix B. Based on our stability analyses, the permanent stabilization system meets the global stability FS requirements identified for the project. The compound global stability of the system meets the static FS of 1.5 and seismic FS of 1.1.

Corrosion Potential

The level of corrosion protection for the steel is primarily dependent on the service life of the anchor, the aggressivity of the environment, and installation methods and consequences of failure. To account for a 75-year design life, all steel that will be used for construction of the proposed stabilization system will have corrosion protection through either epoxy coating or galvanization. The corrosion protection for steel elements for the project will ultimately depend on the material availability at the time of construction.

While potential corrosion will be resolved through epoxy coating or galvanization, we conservatively evaluated the corrosion potential of micropiles assuming the bar will be plain. This approach used reduced axial (tensile and compression) structural capacities for design of the proposed stabilization system. The corrosion potential of micropiles was evaluated using the Federal Highway Administrations Publication FHWA-CFL/TD-10-002 titled Hollow Bar Soil Nails: Review of Corrosion Factors and Mitigation Practice and GEC Circular No. 7. Calculations are provided in the following pages.

Structural Elements – Material Properties

All material properties used in structural elements are based on established values from the manufacturer. Structural properties are provided in Appendix C. Key structural elements included in this project are as follows:

- Grout
- Reinforced shotcrete

- 51mm hollow bars
- Steel bearing plates
- Hex nuts
- Couplers

Appendix A - Construction Sequence

Construction Sequence

GeoStabilization International® anticipates that the work will be performed following the general construction sequence below. Work may be completed simultaneously or in varying sequence upon completion mobilization and setup up of temporary facilities and set up of erosion control measures.

1. Delineate limits of stabilization. notify local utilities providers to locate and mark potential underground facilities. daylighting of utilities in potential conflict, as necessary (by others).
2. Prepare the work area for micropile installation and cutoff wall construction:
 - a. Install erosion control fence at the top of the existing seawall to limit soil erosion during construction.
 - b. Minor re-shaping of existing scarp and surrounding grades may be needed to facilitate construction of the micropile cutoff wall.
 - c. Mark the locations of the proposed stabilization elements with survey marking paint.
3. Installation of micropile elements. each element will be grouted during drilling unless directed otherwise by GSI engineer.
4. Construct the cutoff wall:
 - a. Place reinforcing steel and drain strips per these drawings.
 - b. Use wood or similar formwork on the north side of the cutoff wall to facilitate shotcrete placement.
 - c. Place shotcrete from the bottom up to the required thickness detailed in these plans.
5. Prepare area north of the cutoff wall for reinforced soil slope system installation. minor grubbing and grading may be necessary.
6. Install reinforced soil slope system in lifts as detailed in these drawings and per the manufacturer installation procedures.
7. Site cleanup and demobilization from site.
 - a. Concrete, grout, and other construction debris will be removed periodically throughout the work.
 - b. Final cleanup of the site to include reasonable hand cleaning methods like sweeping, spraying with water and removal of trash and debris. major landscaping should not be needed if proper access is granted to gsi throughout the project.

Appendix B - Design Analyses Output

PLAXIS 3D STABILITY MODEL INPUT

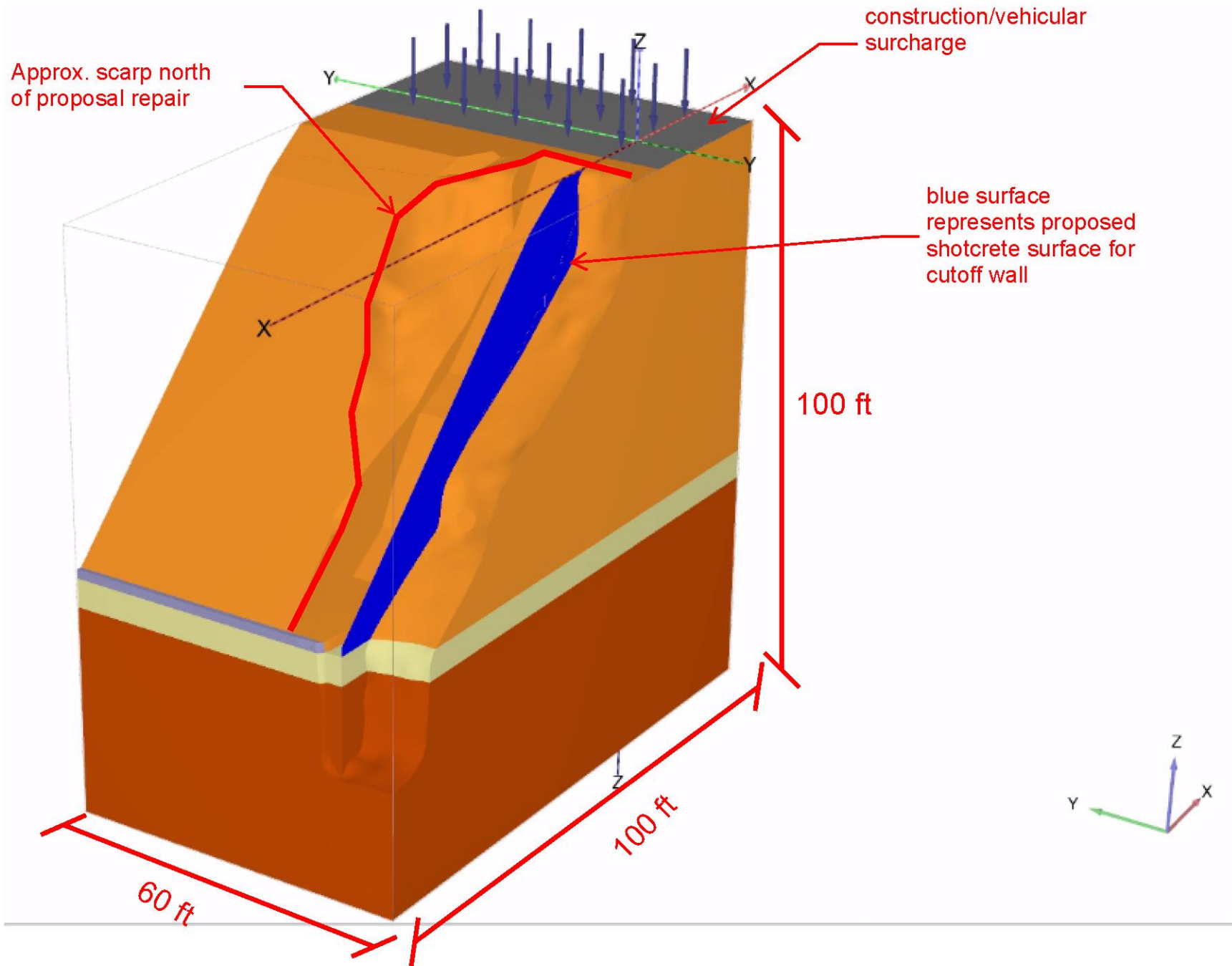

PLAXIS 3D STABILITY MODEL INPUT

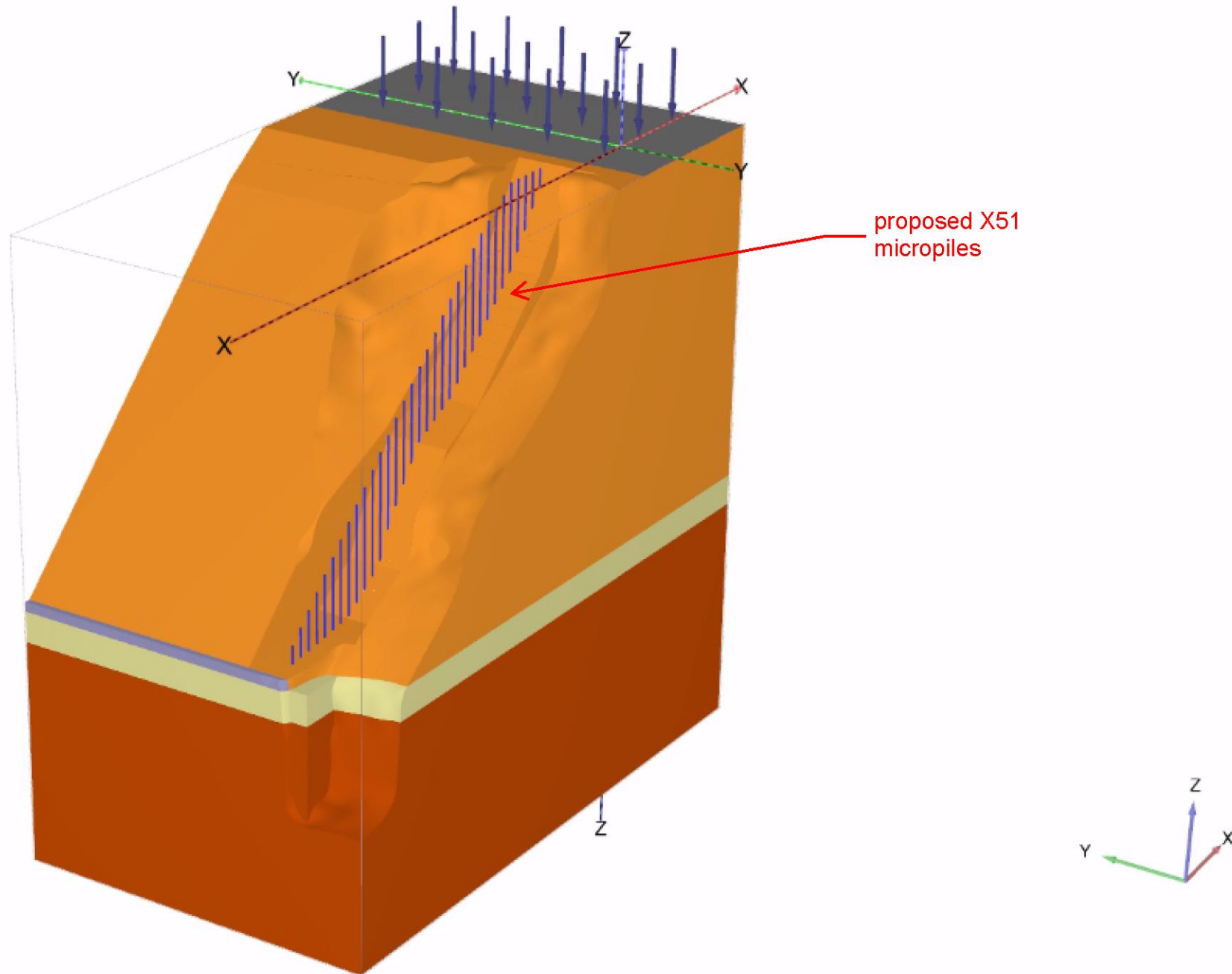

PLAXIS 3D STABILITY MODEL INPUT

light blue is proposed reinforced soil slope

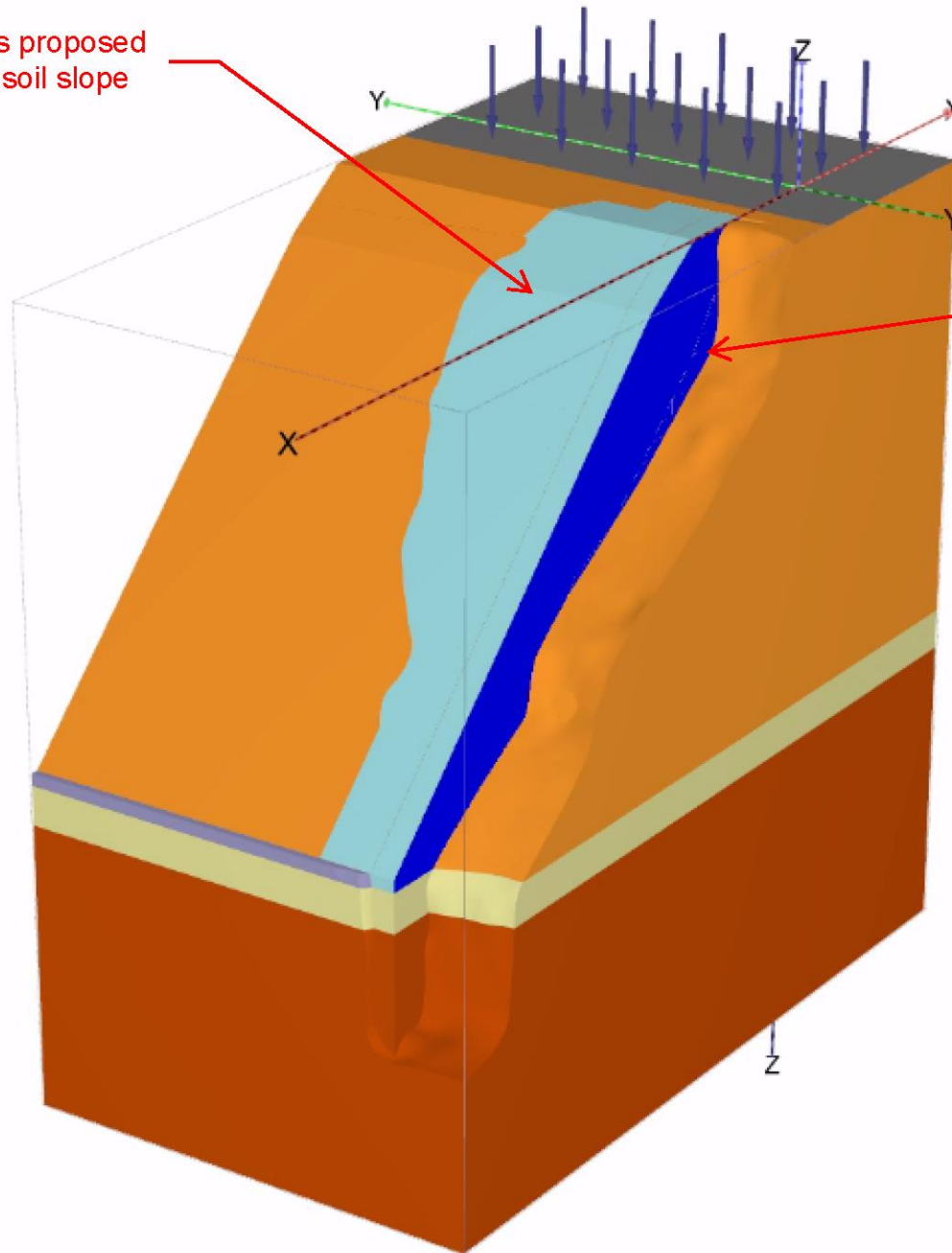

blue is 8" nominal reinforced shotcrete surface

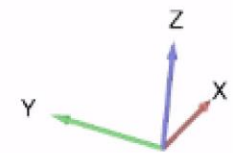

PLAXIS 3D STABILITY MODEL INPUT

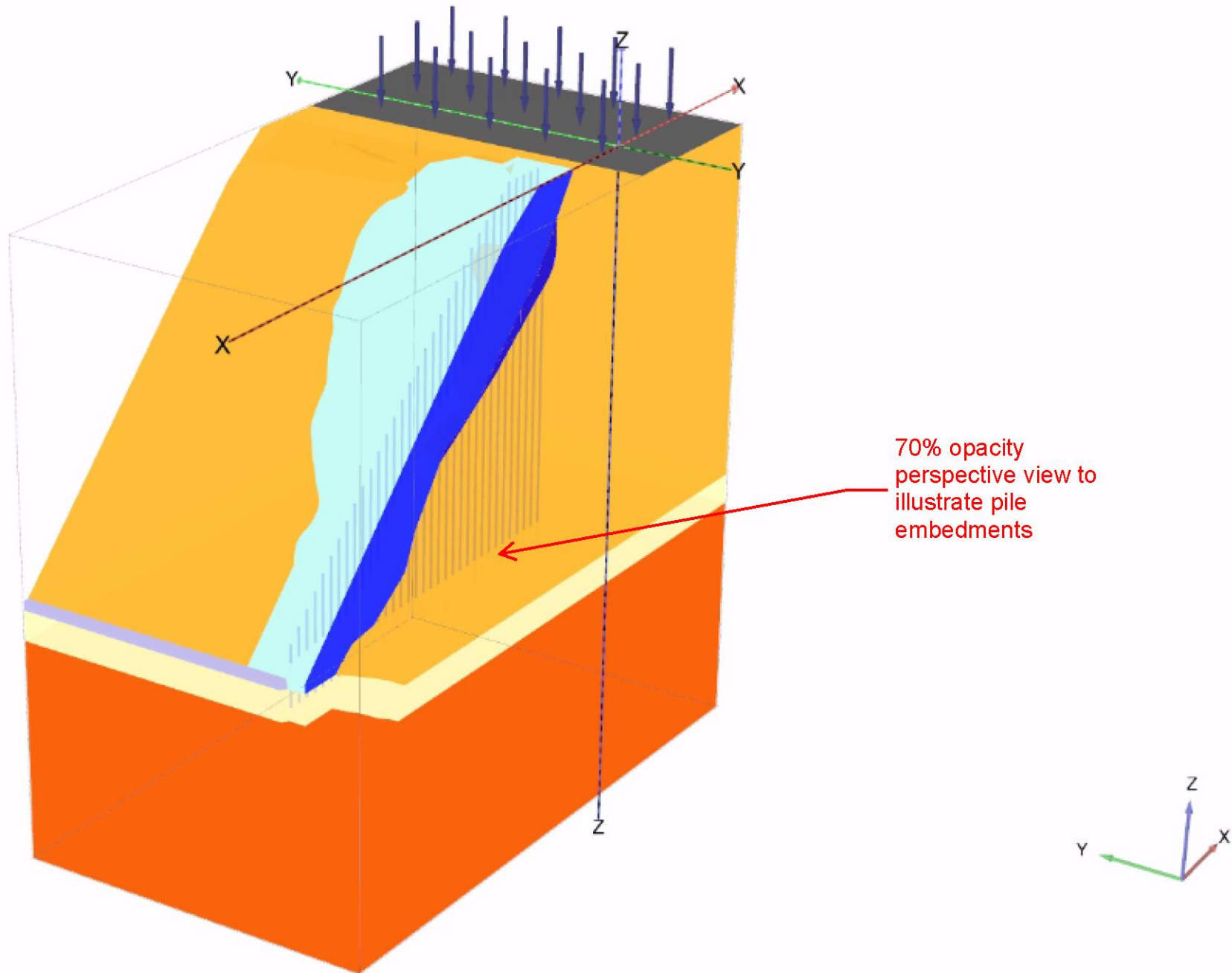

PLAXIS 3D STABILITY MODEL INPUT

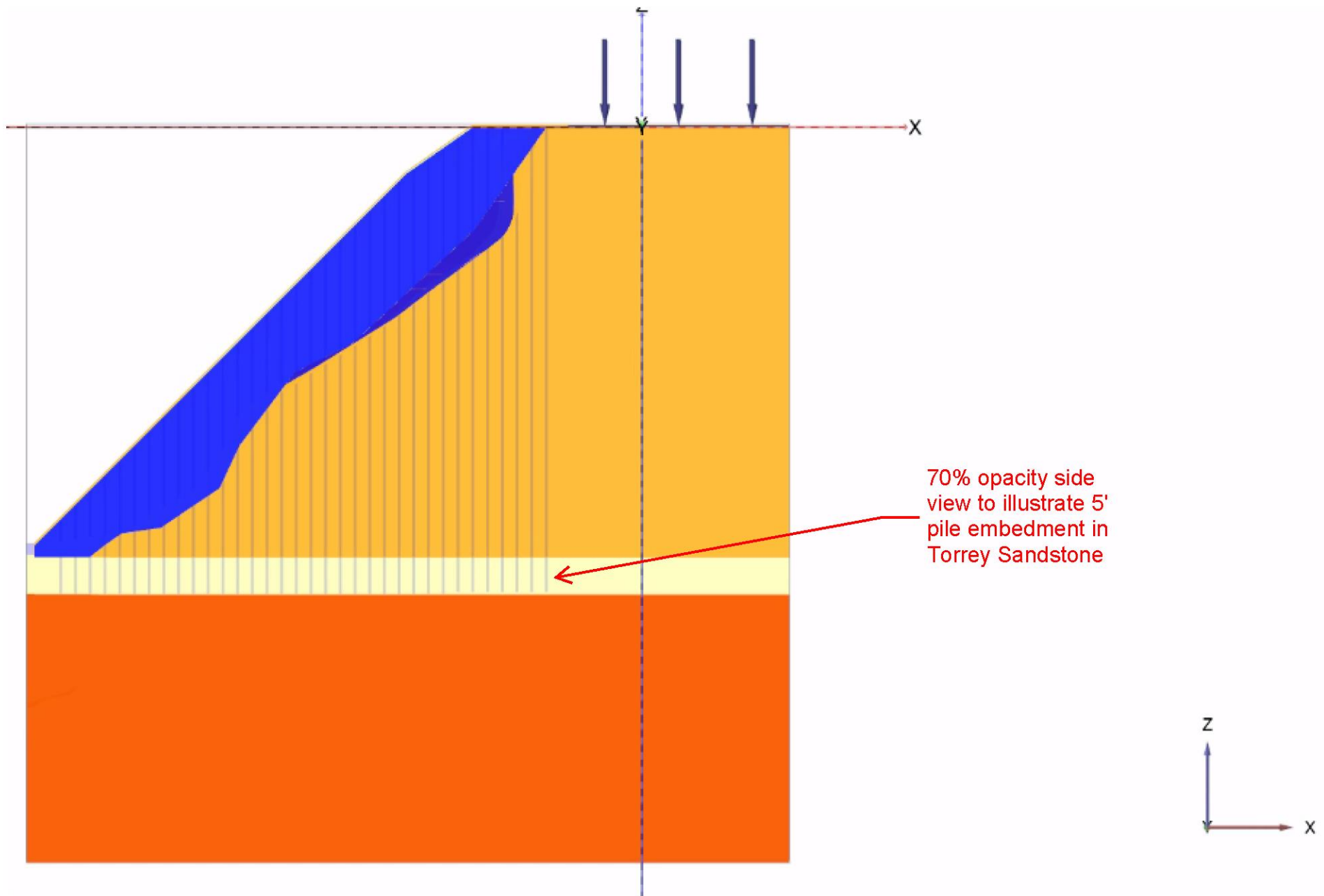

PLAXIS 3D STABILITY MODEL INPUT

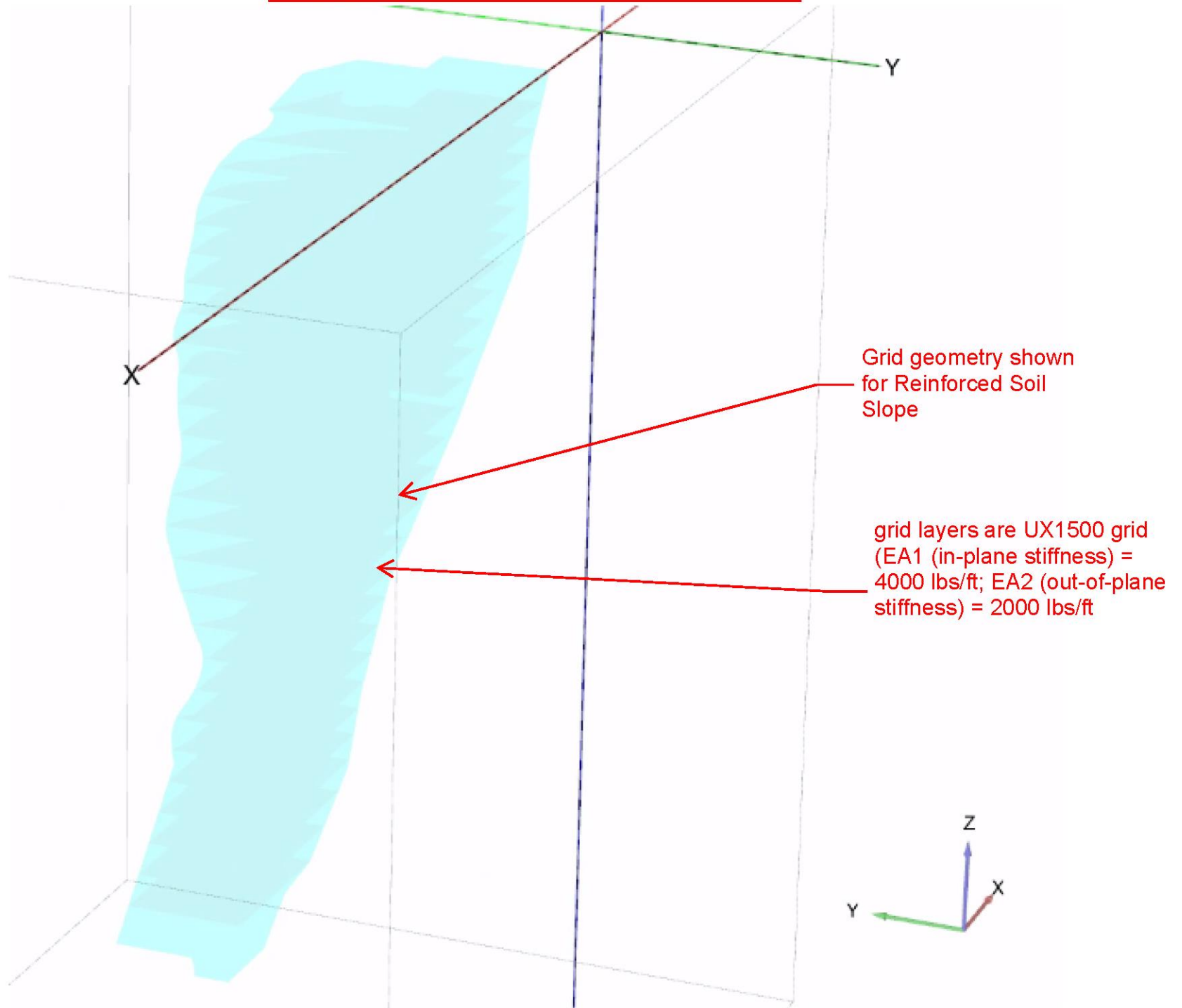

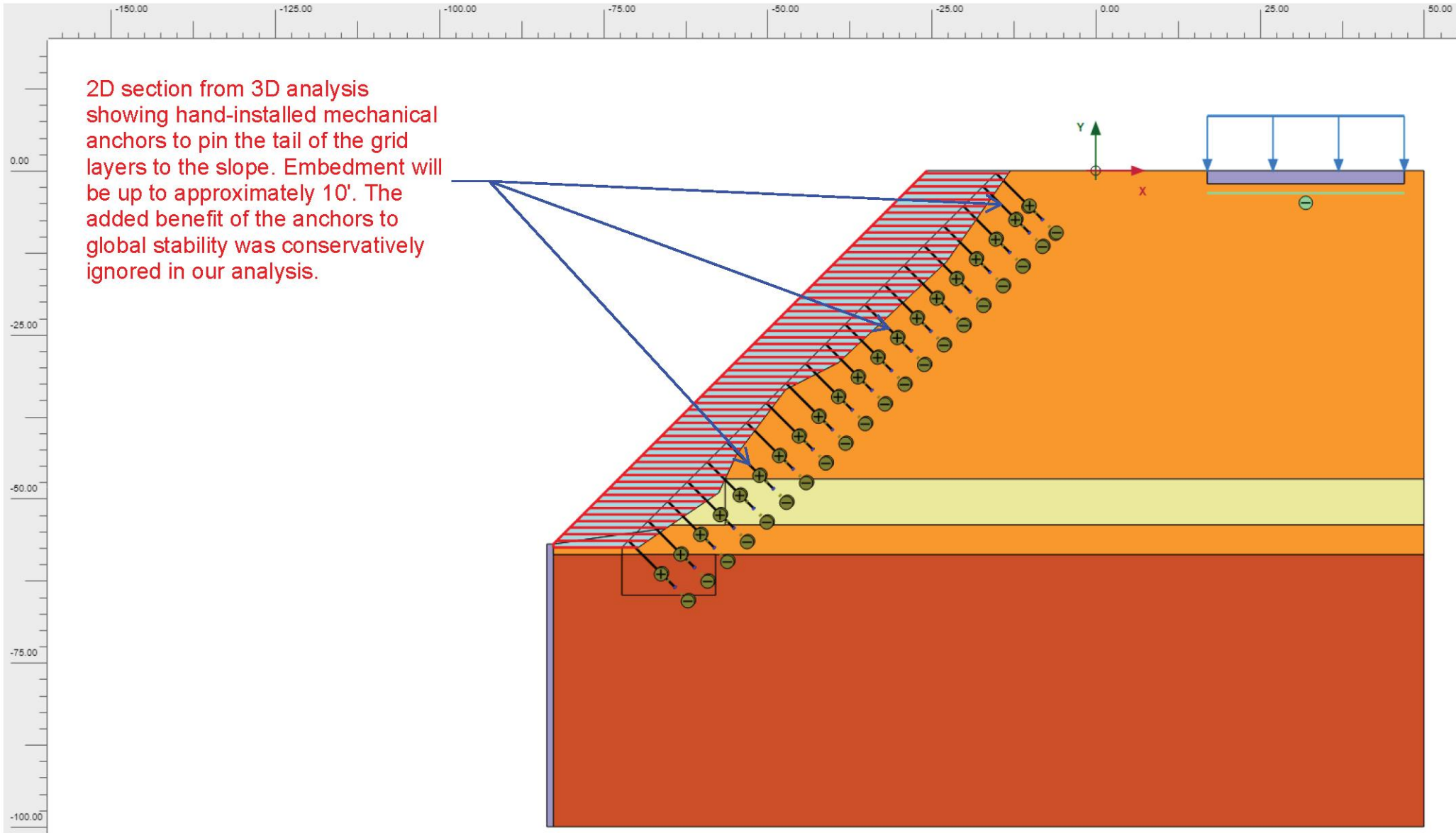

PLAXIS 3D STABILITY MODEL INPUT

2D section from 3D analysis showing hand-installed mechanical anchors to pin the tail of the grid layers to the slope. Embedment will be up to approximately 10'. The added benefit of the anchors to global stability was conservatively ignored in our analysis.



PLAXIS Report

1.1.2.1.1 Materials - Soil and interfaces - HS small

Identification		Terrace Deposits	Fill	Loose Sand
Identification number		1	4	5
Drainage type		Drained	Drained	Drained
Colour				
Comments		(N1)60 = 50	(N1)60 = 50	(N1)60 = 50
γ_{unsat}	lbf/ft ³	110.0	120.0	105.0
γ_{sat}	lbf/ft ³	115.0	125.0	110.0
Dilatancy cut-off		No	No	No
e_{init}		0.5000	0.5000	0.5000
e_{min}		0.000	0.000	0.000
e_{max}		999.0	999.0	999.0
E_{50}^{ref}	lbf/ft ²	1.140E6	1.140E6	1.140E6
$E_{\text{oed}}^{\text{ref}}$	lbf/ft ²	1.140E6	1.140E6	1.140E6
$E_{\text{ur}}^{\text{ref}}$	lbf/ft ²	3.430E6	3.430E6	3.430E6

Generally some cohesion
required in PLAXIS to
prevent singularity in
solver matrix

3D

Identification		Terrace Deposits	Fill	Loose Sand
power (m)		0.5000	0.5000	0.5000
Use alternatives		No	No	No
C_c		6.321E-3	6.321E-3	6.321E-3
C_s		1.891E-3	1.891E-3	1.891E-3
e_{init}		0.5000	0.5000	0.5000
c_{ref}	lbf/ft ²	5.000	10.00	5.000
ϕ (phi)	°	34.00	40.00	32.00
ψ (psi)	°	4.000	10.00	0.000
$\gamma_{0.7}$		0.1090E-3	0.1090E-3	0.1090E-3
G_0^{ref}	lbf/ft ²	2.550E6	2.550E6	2.550E6
Set to default values		No	No	No
v_{ur}		0.2000	0.2000	0.2000
p_{ref}	lbf/ft ²	2089	2089	2089
K_0^{nc}		0.4408	0.3572	0.4701
c_{inc}	lbf/ft ² /ft	0.000	0.000	0.000
Z_{ref}	ft	0.000	0.000	0.000
R_f		0.9500	0.9500	0.9500

Identification		Terrace Deposits	Fill	Loose Sand
Tension cut-off		Yes	Yes	Yes
Tensile strength	lbf/ft ²	0.000	0.000	0.000
Undrained behaviour		Standard	Standard	Standard
Skempton-B		0.9866	0.9866	0.9866
v_u		0.4950	0.4950	0.4950
$K_{w,ref} / n$	lbf/ft ²	140.5E6	140.5E6	140.5E6
Failure criterion		Mohr-Coulomb	Mohr-Coulomb	Mohr-Coulomb
Stiffness		Standard	Standard	Standard
Strength		Manual	Rigid	Manual
R_{inter}		0.7000	1.000	0.7000
Consider gap closure		Yes	Yes	Yes
δ_{inter}		0.000	0.000	0.000
Cross permeability		Impermeable	Impermeable	Impermeable
Drainage conductivity $_1, dk$	ft ³ /day/ft	0.000	0.000	0.000
Drainage conductivity $_2, dk$	ft ³ /day/ft	0.000	0.000	0.000
K_o determination		Automatic	Automatic	Automatic
$K_{0,x} = K_{0,y}$		Yes	Yes	Yes

Identification		Terrace Deposits	Fill	Loose Sand
$K_{0,x}$		0.4408	0.3572	0.4701
$K_{0,y}$		0.4408	0.3572	0.4701
OCR		1.000	1.000	1.000
POP	lbf/ft ²	0.000	0.000	0.000
k_x	ft/day	0.8607	0.8607	0.8607
k_y	ft/day	0.8607	0.8607	0.8607
k_z	ft/day	0.8607	0.8607	0.8607
e_{init}		0.5000	0.5000	0.5000
S_s	1/ft	0.000	0.000	0.000
c_k		1000E12	1000E12	1000E12

1.1.2.1.2 Materials - Soil and interfaces - Hoek-Brown

Identification		Terry Sandstone
Identification number		2
Drainage type		Drained
Colour		
Comments		
γ_{unsat}	lbf/ft ³	120.0
γ_{sat}	lbf/ft ³	125.0
Dilatancy cut-off		No
e_{init}		0.5000
e_{min}		0.000
e_{max}		999.0
E'_{rm}	lbf/ft ²	20.89E6
ν (nu)		0.1500
$ \sigma_{\text{ci}} $	lbf/ft ²	3.655E6

Identification		Terry Sandstone
m_i		17.00
GSI		80.00
D		0.000
m_b		8.322
s		0.1084
a		0.5006
σ_t	lbf/ft ²	47.59E3
σ_c	lbf/ft ²	-1.202E6
Ψ_{max}	o	0.000
σ_ψ	lbf/ft ²	0.000
Undrained behaviour		Standard
Stiffness		Standard
Strength		Manual
R_{inter}		0.7000
Consider gap closure		Yes
δ_{inter}		0.000
Cross permeability		Impermeable

Identification		Terry Sandstone
Drainage conductivity $_1$, dk	ft ³ /day/ft	0.000
Drainage conductivity $_2$, dk	ft ³ /day/ft	0.000
K_0 determination		Manual
$K_{0,x} = K_{0,y}$		Yes
$K_{0,x}$		1.000
$K_{0,y}$		1.000
k_x	ft/day	0.000
k_y	ft/day	0.000
k_z	ft/day	0.000
e_{init}		0.5000
c_k		1000E12

1.1.2.1.3 Materials - Soil and interfaces - Concrete



Identification		Concrete_4ksi
Identification number		3
Drainage type		Non-porous
Colour		
Comments		
γ_{unsat}	lbf/ft ³	145.0
γ_{sat}	lbf/ft ³	145.0
Dilatancy cut-off		No
e_{init}		0.5000
e_{min}		0.000
e_{max}		999.0
E_28	lbf/ft ²	734.0E6
ν (nu)		0.1000
$f_{c,28}$	lbf/ft ²	1.150E6

Identification		Concrete_4ksi
f_{c0n}		0.1500
f_{cfn}		0.000
f_{cun}		0.000
$G_{c,28}$	lbf/ft	7341
ϕ_{max}	°	37.00
ψ	°	5.000
α_{fc}		1.000
$f_{t,28}$	lbf/ft ²	80.64E3
f_{bin}		0.000
$G_{t,28}$	lbf/ft	734.0
γ_{ft}		1.000
Time dependent behaviour		No
E_1/E_{28}		1.000
$f_{c,1}/f_{c,28}$		1.000
ϵ_{cp}^p		-1.400E-3
a		18.00
Shrinkage behaviour		No

Identification		Concrete_4ksi
ϵ_{∞}^{shr}		0.000
$t_{50,shr}^{^p}$	day	0.000
Creep behaviour		No
$\phi^{^cr}$		0.000
$t_{50}^{^cr}$	day	0.000
Stiffness		Standard
Strength		Rigid
R_{inter}		1.000
Consider gap closure		Yes
δ_{inter}		0.000
Cross permeability		Impermeable
Drainage conductivity $_1, dk$	ft ³ /day/ft	0.000
Drainage conductivity $_2, dk$	ft ³ /day/ft	0.000
K_0 determination		Automatic
$K_{0,x} = K_{0,y}$		Yes
$K_{0,x}$		0.3982
$K_{0,y}$		0.3982

Identification		Concrete_4ksi
k_x	ft/day	0.000
k_y	ft/day	0.000
k_z	ft/day	0.000
e_{init}		0.5000
c_k		1000E12

1.1.2.2 Materials - Geogrids -

Identification		Pyrawall 75	UX1700
Identification number		1	2
Comments			
Colour			
Material type		Elastic	Elastic
Isotropic		No	Yes
EA ₁	lbf/ft	4000	3840
EA ₂	lbf/ft	2000	3840
GA	lbf/ft	1000	1920
Identification number		1	2
Identification number		1	2

1.1.2.3 Materials - Plates -

Identification		SC_8in
Identification number		1
Comments		6ksi
Colour		
Material type		Elastic
d	ft	0.6700
γ	lbf/ft ³	140.0
Isotropic		Yes
E ₁	lbf/ft ²	3.000E9
E ₂	lbf/ft ²	3.000E9
ν_{12}		0.2500
G ₁₂	lbf/ft ²	1.200E9
G ₁₃	lbf/ft ²	1.200E9
G ₂₃	lbf/ft ²	1.200E9

Identification		SC_8in
Rayleigh α		0.000
Rayleigh β		0.000
Prevent punching		No
Identification number		1

1.1.2.4 Materials - Beams -

Equivalent stiffness based on 4.5"
drillhole with X51 mm steel bar;
contribution of grout stiffness ignored
assuming fully cracked condition

Identification		X51
Identification number		1
Comments		
Colour		
Material type		Elastoplastic
E	lbf/ft ²	572.0E6
γ	lbf/ft ³	50.00
Beam type		Predefined
Predefined beam type		Massive circular beam
Diameter	ft	0.3750
A	ft ²	0.1104
I ₂	ft ⁴	0.9707E-3
I ₃	ft ⁴	0.9707E-3
Yield stress σ_y	lbf/ft ²	1.239E6

corresponding
nominal moment of
6.304 kip-ft per steel
section

Identification		X51
Critical direction		Local direction 2
W_2	ft ³	5.177E-3
Rayleigh α		0.000
Rayleigh β		0.000
Identification number		1

PLAXIS 3D STABILITY MODEL INPUT

Geogrid - Pyramat 75

Mechanical Thermal

Property	Unit	Value
Material set		
Identification		Pyramat 75
Comments		
Colour		255, 0, 0
Material type		Elastic
Properties		
Isotropic		<input type="checkbox"/>
EA ₁	lbf/ft	4000
EA ₂	lbf/ft	2000

Colour

Red: 255, Green: 0, Blue: 0
Hue: 0, Saturation: 100%, Lightness: 50%

Favourites

--	--	--	--	--	--	--	--	--	--

Save colour as favourite 1

OK Cancel

PLAXIS 3D STABILITY MODEL OUTPUT

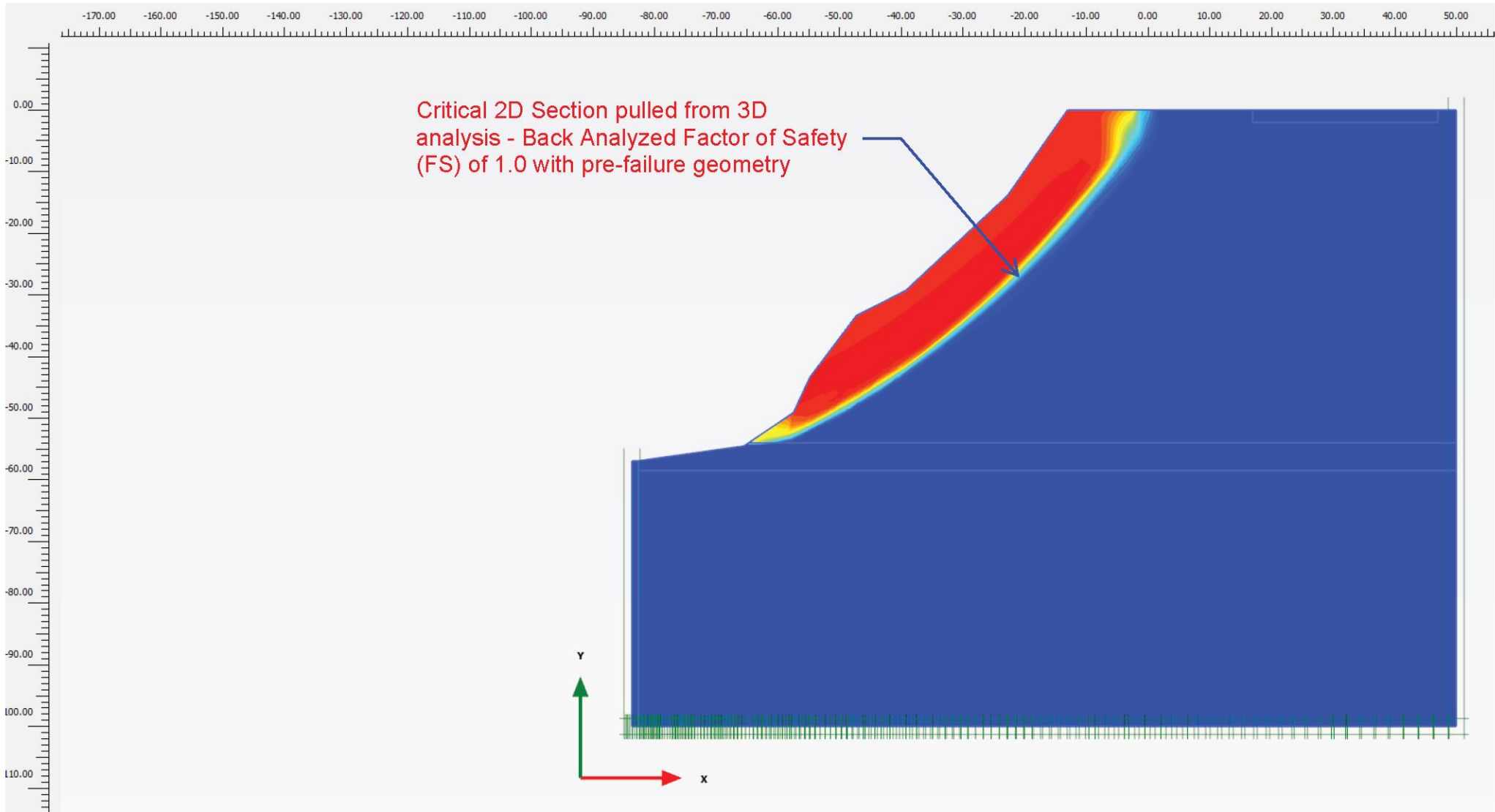

PLAXIS 3D STABILITY MODEL OUTPUT

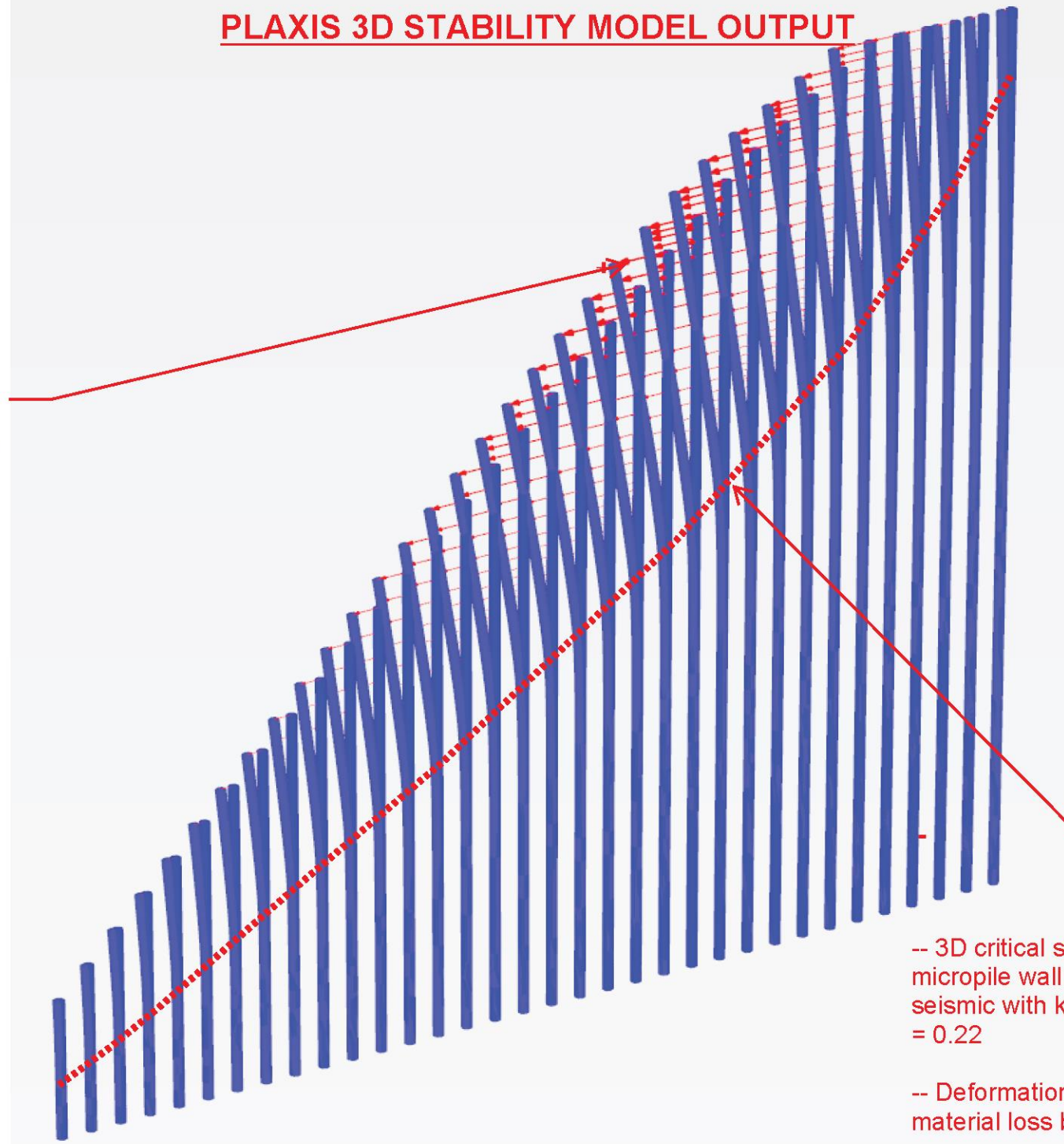

deformed piles from pushover analysis. System designed to accommodate up to 1" of total pile deformation.

-- 3D critical slip surface along micropile wall. FS = 1.5 static and 1.1 seismic with $kh = 0.5PGA = 0.5 (0.44) = 0.22$

-- Deformation accounts for up to 6ft of material loss below shotcrete facing.

PLAXIS 3D STABILITY MODEL OUTPUT

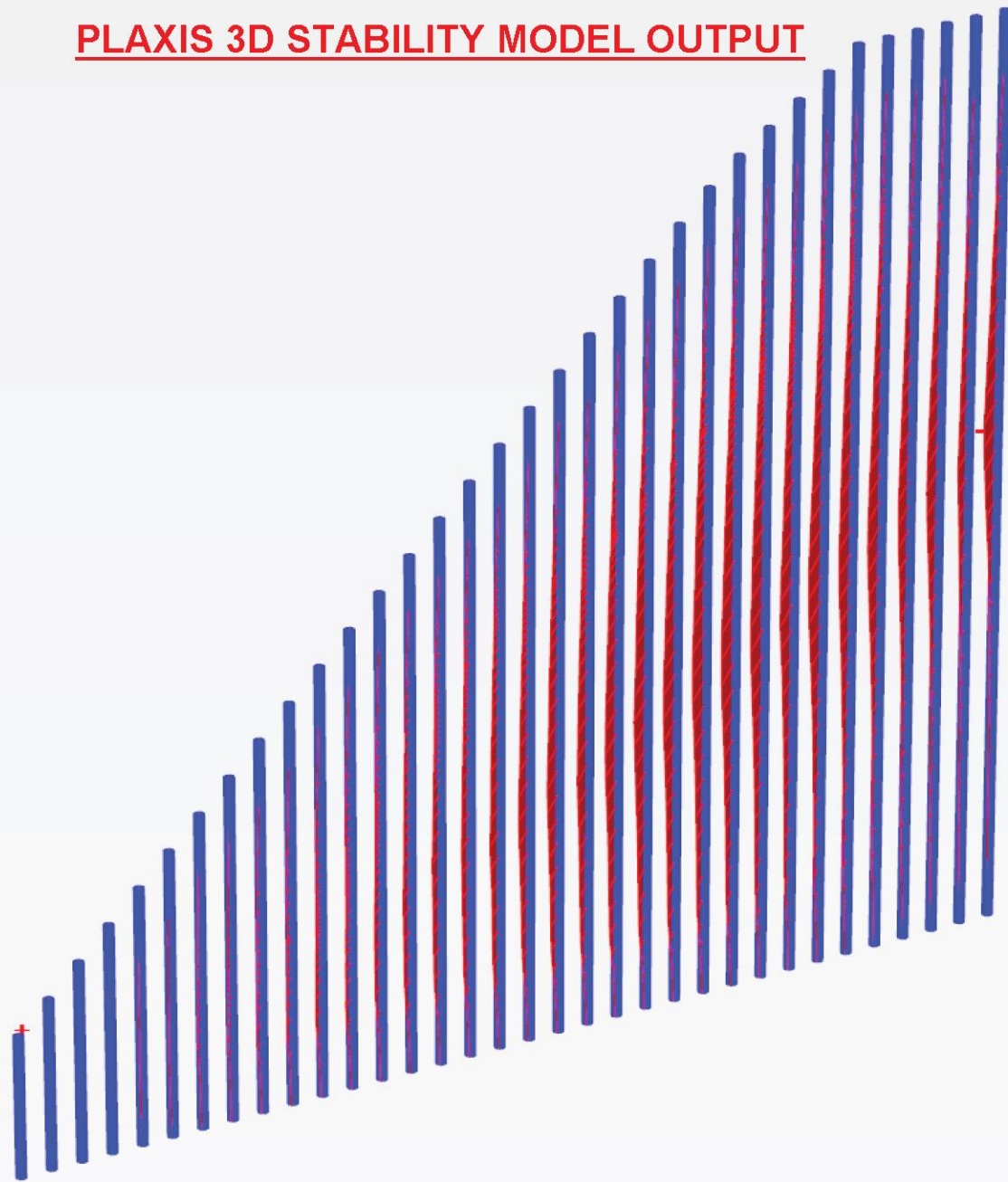

Axial forces N (scaled up $0.100 \cdot 10^{-3}$ times)

Maximum value = 679.9 lbf (Element 602 at Node 221)

Minimum value = $-39.88 \cdot 10^3$ lbf (Element 136 at Node 2647)

-- Design Test Load =
DTL = 40 kips / 65 ft =
615 lbs/ft < Design Bond
of 750 lbs/ft, OK

-- Loading accounts for
up to 6ft of material loss
below shotcrete facing.

PLAXIS 3D STABILITY MODEL OUTPUT

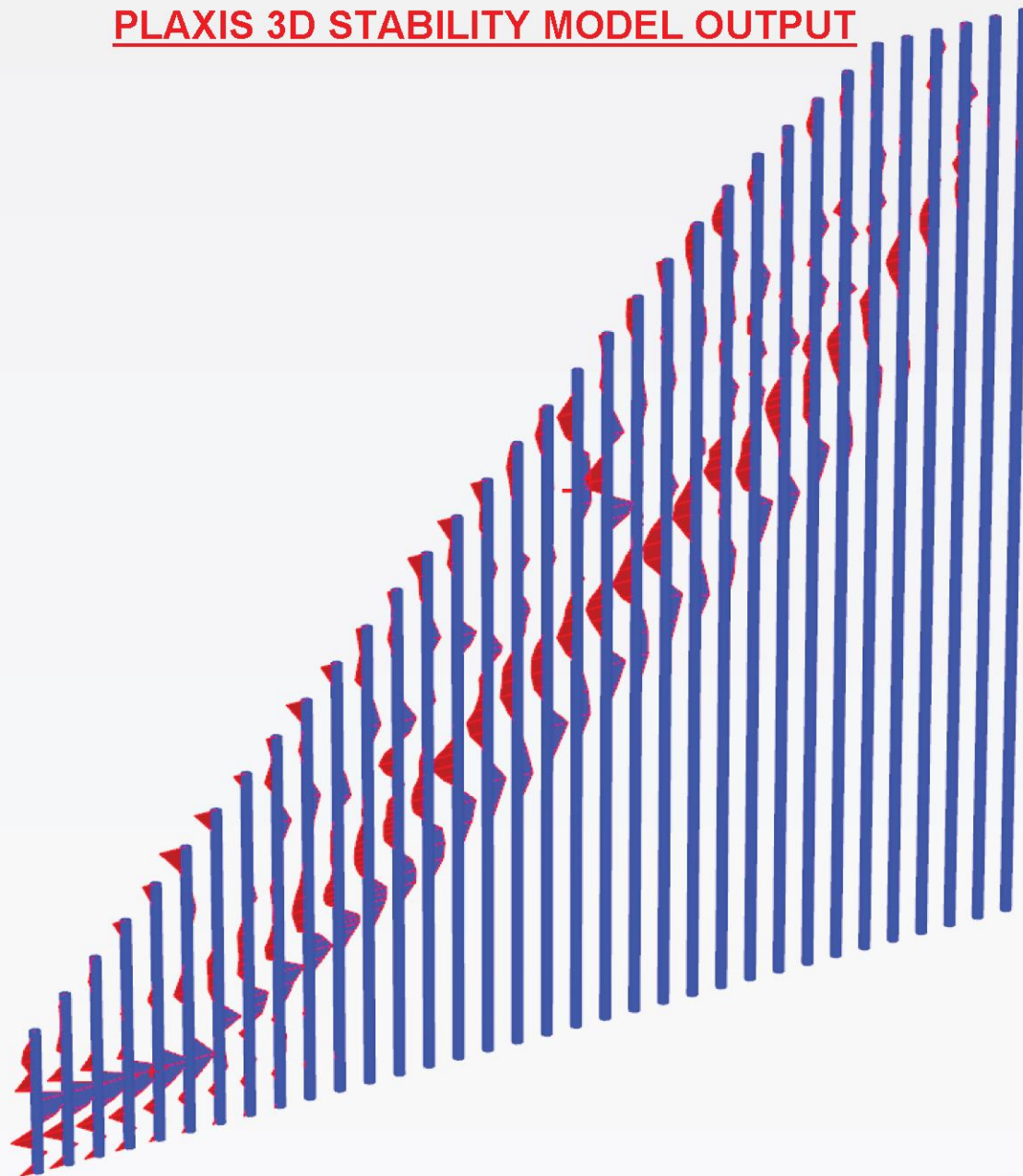

Shear forces Q_{12} (scaled up $5.00 \cdot 10^{-3}$ times)

Maximum value = 551.1 lbf (Element 586 at Node 279)

Minimum value = -387.3 lbf (Element 354 at Node 2444)

-- Shear Strength Utilization = 551 lbs / 17,000 lbs = 3%

-- Accounts for up to 6ft of material loss below shotcrete facing.

PLAXIS 3D STABILITY MODEL OUTPUT

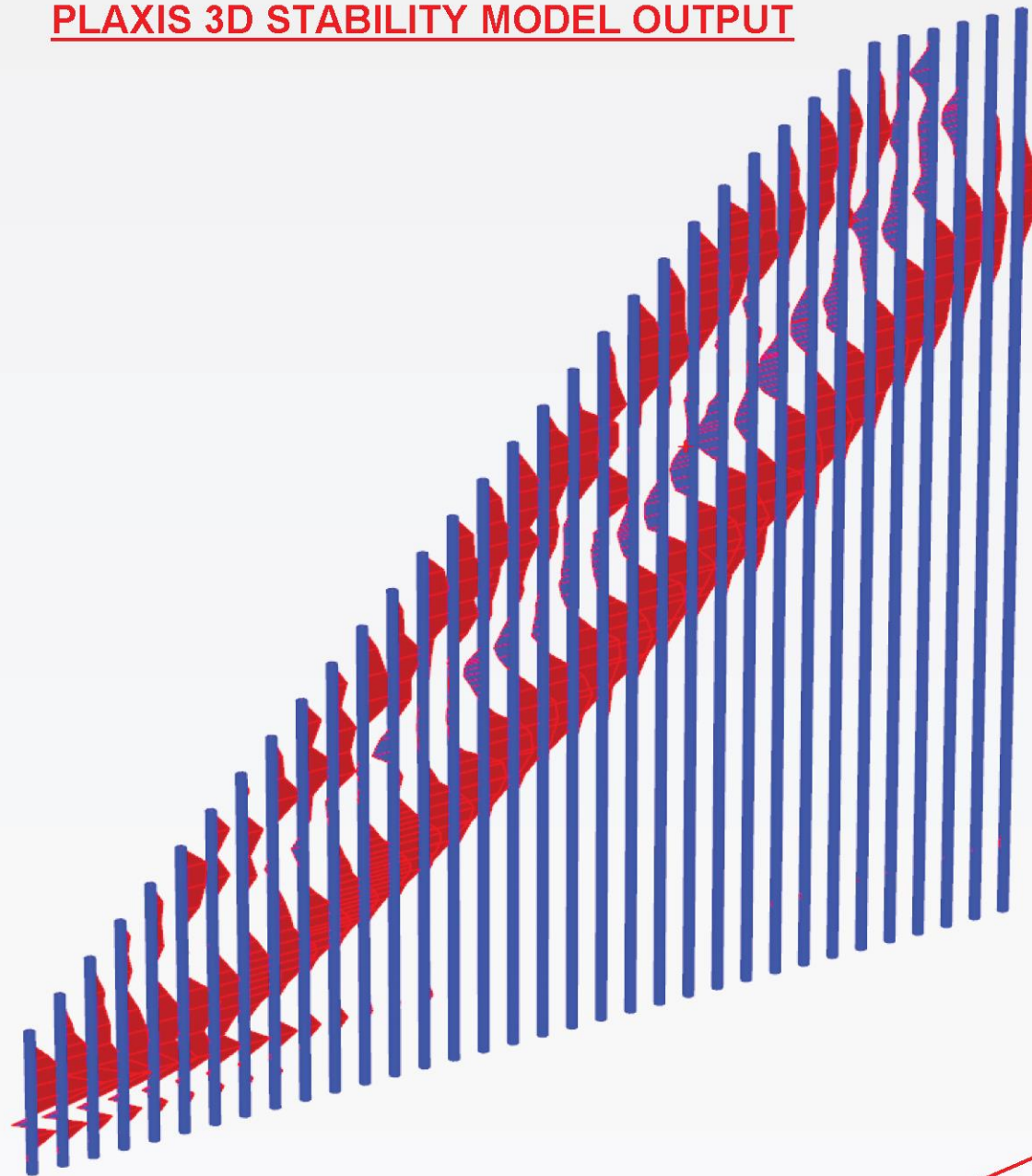

Bending moments M_3 (scaled up $5.00 \cdot 10^{-3}$ times)

Maximum value = 364.3 lbf ft (Element 265 at Node 2955)

Minimum value = -985.4 lbf ft (Element 592 at Node 280)

-- Moment Utilization
= $986 \cdot 1.1 \text{ lbs-ft} / 6400 \text{ lbs-ft} = 17\%$

-- Accounts for up to 6ft of material loss below shotcrete facing.

PLAXIS 3D STABILITY MODEL OUTPUT

Critical 2D section pulled from 3D analysis - max strain increment in the grid reinforcement is ~1% of ultimate value.

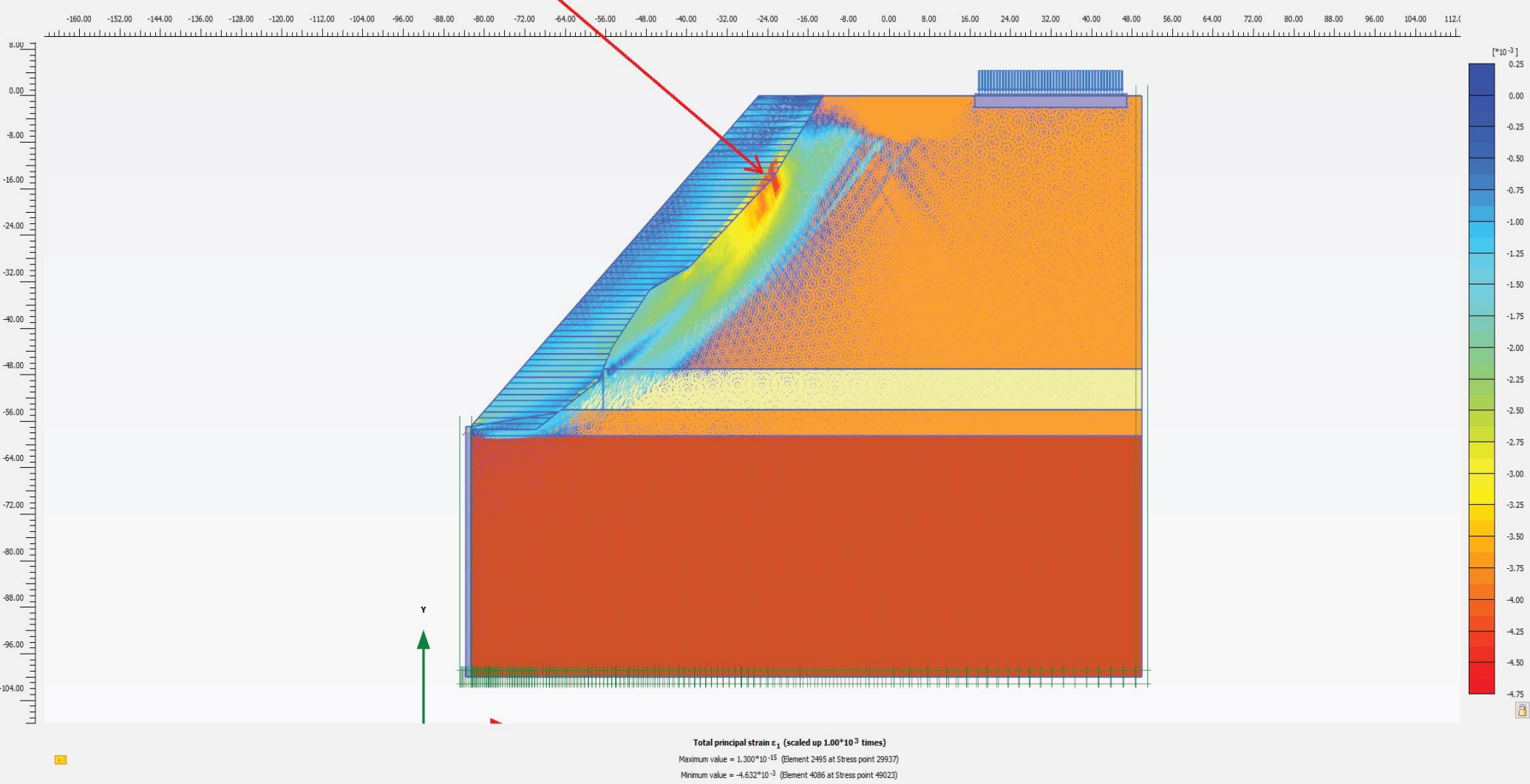

Critical 2D section pulled from 3D analysis.

PLAXIS 3D STABILITY MODEL OUTPUT

-- static global stability FS = 1.51

-- seismic global stability FS = 1.12

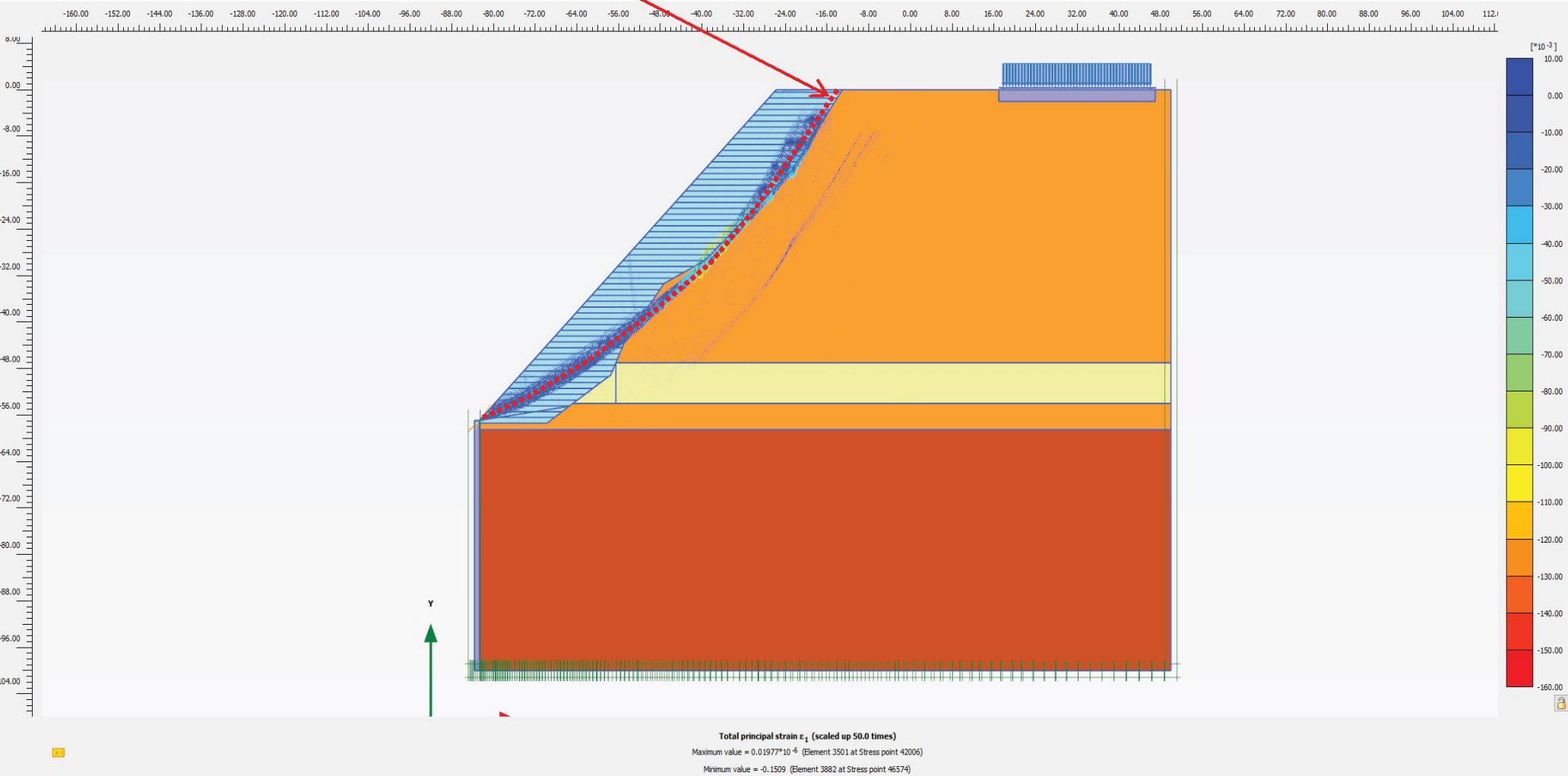

Appendix C - Calculations

Facing Calculations

Design Approach/Assumptions –

- ACI 318-14 Code Edition.
- Reinforced shotcrete facing treated as a cantilevered beam/one-way slab.
 - L/H ratio > 2
- Conservatively assumed full lateral earth pressure (dead load) from RSS acting on wall.
 - Actual lateral pressure is over 100 times less than that used in design of the facing (Crouse and Wu, 2003).
- Seismic load treated as live load.
 - Mononobe-Okabe Method used to calculate dynamic lateral earth pressure.
- Wall height (length of beam/slab) of 12 feet used for length of beam in moment calculation.

Reinforced Shotcrete Design – Check For Steel Percentage

Concrete Beam/1-way Slab Calculator	
Beam Geometries: height of the beam h = 18 in width of the beam b _w = 8 in cover cov = 2 in distance to rebar d = 16 in 0 for beam, 1 for slab var = 1 0.75 for spiral, 0.65 for other var 2 = 0.65	<p>Figure 1: Concrete Beam Diagram in a balanced condition</p>
Concrete Properties: Strength of the Steel f _y = 60000 psi Strength of the Concrete f _c = 4000 psi Stress Block Ratio β ₁ = 0.85 Strength Reduction Factor Φ = 0.90 Steel in Member A _s = 2.05 in ²	Equations Used: $A_{s-min} (beams) = \frac{3\sqrt{f_c} b_w d}{f_y} \leq \frac{200 b_w d}{f_y}$ $A_{s-min} (slabs) = 0.002 b_w d$ $a = \frac{A_s f_y}{0.85 f_c' b}$ $c = \frac{a}{\beta_1} \quad \epsilon_s = 0.003 \left(\frac{d-c}{c} \right)$ $M_n = A_s f_y \left(d - \frac{a}{2} \right)$
Check Min Steel: Min amount of steel: A _{s-min} = 0.26 in ² Steel to be used: A _s = 2.05 in ²	<p>Figure 2: Tension/Compression/Transition zones with corresponding Strength Reduction Factors</p>
Check Tension Controlled: Find Compression depth: a = 4.532353 in Tension control check: c = 5.33218 ε _t = 0.006002 Tension Controlled	
Solve for Capacity: M _n = 1693106 lb-in ΦM_n = 1523795 lb-in 127.0 k-ft	
Notes: 1) Created using ACI 318-14 2) If ε _t is greater than 0.005, the beam/slab is tension controlled. If ε _t is less than 0.002, the beam/slab is compression controlled. If it is between the two, the beam/slab is in transition (See Figure 2).	

Reinforced Shotcrete Design – Check Against Loads

f'c (psi)	4,000	psi	fy	60	psi
L (ft)	144	in.	Φ	0.9	in.
L.R.	W4.0 mesh + #5 bar + X51 bar	Area= 1.94	T.R.	W4.0 mesh + #5 bar	Area= 0.13
b	8	in.			
DL	4	k	LL	1	k
φ =	0.9				
h=	18	in.			
d=	16	in.			
W _{DL} =	3.5	k/ft			
W _{LL} =	1.4	k/ft			
W _u =	6.5	k/ft			
M _u =	117.5	k-ft			
R _n =	0.7648	ksi			
ρ=	0.0127	%			
ρ _{min} =	0.0033	%			
ρ _{max} =	18.0625	%			
Steel Percentage is Satisfactory					
Steel to be Used, A _s	2.07	in ²			
A _s calc.	A _{s, mesh} *2 layers + (A _{s, #5 bar} *2/ft of wall) + A _{s, X51} *1 full bar between each span	in ²			
	0.119*2+(0.3*2/18)+1.8*2*0.5	in ²			
φ Mn	127.0000	k-ft			
φ Mn > Mu	Design is Satisfactory				

Reinforced Shotcrete Design – Check Against Loads - Formulas Shown

ϕ =	0.9	
h =	18	in.
d =	=B61-2	in.
W_{DL} =	=(0.5*0.39*125*(B55/12)^2)*0.001	k/ft
W_{LL} =	=2169.41*0.001*(B57/12)	k/ft
W_u =	=(1.2*B63)+(B64*1.6)	k/ft
M_u =	=((B65*(B55/12)^2)/8)	k-ft
R_n =	=B66*12/(B60*B57*B62^2)	ksi
ρ =	(((0.85*B54)/E54)*(1-(SQRT(1-(2*B67)/(0.85*B54))))))	%
ρ_{min} =	=200/(E54*1000)	%
ρ_{max} =	=(3/8)*((0.85*B54*1000*0.85)/(60*1000))	%
=IF(AND(B68>B69,B68<B70), "Steel Percentage is Satisfactory", "Steel Percentage is not Satisfactory")		
Steel to be Used, A_s	=0.119*2+(0.3*2/B61)+1.8*2*0.5	in ²
A_s calc.	$A_{s, mesh}$ *2 layers + ($A_{s, \#5 bar}$ *2/ft of wall) + $A_{s, \#51}$ *1 full bar between each span	in ²
	0.119*2+(0.3*2/18)+1.8*2*0.5	in ²
ϕ Mn	127	k-ft
ϕ Mn > M_u	=IF(B76>B66, "Design is Satisfactory", "Design is not Satisfactory")	

Tensile and Compression Capacity

Corrosion Calculations FHWA-CFL/TD-10-002

Material Properties

Bar Type	X51
Bar Area (Ac)	1.795 sq in
Outside Diameter (D)	2 in
Inside Diameter (Di)	1.187 in
Yield Strength (Fy)	152.0 kips
Grade Steel (fy)	85 ksi
Design Life	75 yr

FHWA Sacrificial Steel Calculations

$$D_o = \left[\left(\frac{4 * A_c}{\pi} \right) + (d_i^2) \right]^{0.5}$$

Do	1.92 in	Calculated Outer Diameter
----	---------	---------------------------

X	4.00 mm	Thickness of Sacrificial Steel metric
---	---------	---------------------------------------

X	0.158 in	Thickness of Sacrificial Steel uscs
---	----------	-------------------------------------

$$D_{eff} = D_o - 2X$$

Deff	1.61 in	Effective Bar Diameter
------	---------	------------------------

$$A_{red} = \frac{\pi * D_{red}^2}{4} - \frac{\pi * D_{in}^2}{4}$$

Areduced	0.92 sq in	Reduced Steel Area
----------	------------	--------------------

$$R_T = A_{reduced} * f_y$$

RT	117.8 kips	Nominal Tensile Capacity
----	------------	--------------------------

ΦT	0.75	ASTM A615 Tensile Resistance
----	------	------------------------------

T Reduced	88.4 kips	Reduced Tensile Capacity
-----------	-----------	--------------------------

Load Combination Factor	1.35	Static Load Combination Factor
-------------------------	------	--------------------------------

T Design	65.5 kips	Design Tensile Capacity
----------	-----------	-------------------------

Bar tensile capacity for 75-yr design life – Static condition

Corrosion Calculations FHWA-CFL/TD-10-002

Material Properties

Bar Type	X51
Bar Area (Ac)	1.795 sq in
Outside Diameter (D)	2 in
Inside Diameter (Di)	1.187 in
Yield Strength (Fy)	152.0 kips
Grade Steel (fy)	85 ksi
Design Life	75 yr

FHWA Sacrificial Steel Calculations

$$D_o = \left[\left(\frac{4 * A_c}{\pi} \right) + (d_i^2) \right]^{0.5}$$

Do	1.92 in	Calculated Outer Diameter
X	4.00 mm	Thickness of Sacrificial Steel met
X	0.158 in	Thickness of Sacrificial Steel uscs
$D_{eff} = D_o - 2X$		
Deff	1.61 in	Effective Bar Diameter
$A_{red} = \frac{\pi * D_{red}^2}{4} - \frac{\pi * D_{in}^2}{4}$		
Areduced	0.92 sq in	Reduced Steel Area
$R_T = A_{reduced} * f_y$		
RT	117.8 kips	Nominal Tensile Capacity
ΦT	0.75	ASTM A615 Tensile Resistance
T Reduced	88.4 kips	Reduced Tensile Capacity
Load Combination Factor	1.00	Static Load Combination Factor
T Design	88.4 kips	Design Tensile Capacity

Bar tensile capacity for 75-yr design life – Seismic condition

Allowable Compression Loads - Micropiles

Pile Dimensions / Properties		
Bar Type	X51 -	
Bar Dia. (OD)	2 in	
Bar Dia. (ID)	1.187 in	
Hole Dia.	4.5 in	
Reduced Area of Steel	0.92 in ²	<= Reduced for Corrosion
Area of Grout	14.98 in ²	
Steel Fy	85 ksi	
Grout f'c	4 ksi	
FHWA NHI 05-039: Allowable Compression Load		
$P_{c-allowable} = (0.4f'_c \times A_{grout} + 0.47F_{y-bar} \times A_{bar})$		(Eq. 5-7)
P_c-allowable	61 kips	
Max Compression Load	40 kips	
Structural Check	OK	

Bar compression capacity for 75-yr design life

Appendix D - Material Properties

Self-Drilling SuperNails™

- Hollow bar: X51
 - Nominal Diameter: 51 mm (or equivalent) O.D.
 - Minimum Yield Strength: 152 kips (or equivalent)
 - Embedment Length: Per Plans
 - Grouting Pressure: As required for grout return at surface
 - Drilling Fluid: Neat Cement Grout or Air if approved by GSI engineer
 - Corrosion Protection: Sacrificial Steel for a design life of 75 years
 - Centralizers: Not applicable for injection drilling systems
 - Couplers: Shall conform to ASTM A29, similar or greater strength than bar

Material certificates can be submitted upon delivery of material to the site.

Facing Reinforcement

- 8-Inch Nominal Shotcrete
- Welded-Wire Mesh
 - Geometry
 - Size: 4 in x 4 in
 - Diameter of Wire: 4.0 gauge
 - Material
 - Tensile Strength of Wire: 60 ksi
- Bearing Plates: 6"x6"x1/2" ASTM A36
- Steel Nuts: Shall conform to ASTM A108

Drain Strip

12" wide Geocomposite Sheet Drain: Shall be manufactured with a drainage core and a drainage geotextile encapsulating the core. The drainage shall have a minimum compressive strength of 6000 psf when tested in accordance with ASTM D6364. The geotextile shall have a minimum flow rate of 20 gallons per minute per foot of width when tested in accordance with the requirements given in ASTM D 4716.

Shotcrete

Shotcrete shall be a pumpable mixture with a minimum 28-day compressive strength of 4,000 psi. Use type I, I/II, or V cement. Shotcrete shall comply with the requirements of ACI 506.2, "Specifications for Materials, Proportioning and Application of Shotcrete". The wet-mix process consists of thoroughly mixing all ingredients, introducing the mixture into the delivery equipment, and delivering it by positive displacement.

Shotcrete Mix Design

- Minimum 28-day compressive strength: 4,000 psi
- Target water to cement ratio: 0.4 to 0.5
- Target slump: 3 to 4 inches
- Target gradation: ACI No. 2 or as approved by GSI Engineer

Placement:

Weather is a key factor in the placement of shotcrete because it affects how quickly the material matures and gains strength. Refer to the construction drawings for information regarding shotcrete placement and curing in cold and hot weather situations.

Grout

- Minimum 28-day compressive strength: 4,000 psi
- Target water to cement ratio: 0.5 to 0.6
- Density Range: 108.6 to 112.2 pcf
- Portland Cement: Type V



Geo-Drill Injection Anchor System

The Williams Geo-Drill Injection Anchor System is today's solution for a fast and efficient anchoring system into virtually any type of soil. The system has historically been known as a "self-drilling anchoring" because the hollow fully-threaded bar serves as both the drill string and the grouted anchor, thus installation is performed in a single operation. The sacrificial drill bit is threaded onto the end of the Hollow Injection Bar and left in place following drilling. The drilling fluid (air, water, or grout) is introduced through the hollow bar and allows the spoils to flush from the borehole.

The Geo-Drill System is particularly suitable for soils that do not allow for open-hole drilling (i.e. granular soils that are collapsible in nature). In such cases, drilling with a grout fluid serves the purpose of flushing spoils from the borehole and prevents looser, surrounding material from collapsing due to the higher relative density of the grout. Williams Geo-Drill Injection Anchor System should be considered on any project requiring fast production that would otherwise need to involve a casing system in order to maintain borehole stability.



Advantages of the Williams Geo-Drill Injection Anchor System

- Fully domestic system available.
- Fast, single-step anchoring system with simple equipment.
- Eliminates the need for a cased borehole in collapsing soils.
- Efficient installation since drilling and grouting can be performed in a single operation, saving both time and money.
- Continuously drilling and grouting under high pressure causes the grout to permeate into looser soils and creates a bulb-effect for increased bond capacity.
- Suitable for working in limited space and areas of difficult access.
- Multiple ranges of drill bits suitable for most soil conditions.
- Installed with standard track drill (top hammer) or hand-held drilling equipment, eliminating the need for larger casing rigs.
- Continuously threaded bar pattern can be cut and coupled anywhere along its length.
- Domestic available in 10' or 20' lengths, non-domestic available in 3 meter lengths only.
- Corrosion protection systems available upon request.
- FHWA approved for use as a micropile or soil nail (Domestic Hollow Injection Bar only)

B7X1 Domestic Hollow Injection Bar

Bar Diameter	Average Inner Diameter	Minimum Net Area Through Threads	Minimum Ultimate Strength	Minimum Yield Strength	Nominal Weight	Part Number
32 mm (1-1/4")	0.787" (20.0 mm)	0.556 in ² (359 mm ²)	58.4 kips (260 kN)	47.2 kips (210 kN)	2.1 lbs/ft (3.1 kg/m)	B7X1-032N
32S mm (1-1/4")	0.626" (15.9 mm)	0.776 in ² (501 mm ²)	81.5 kips (363 kN)	66.0 kips (294 kN)	2.7 lbs/ft (4.0 kg/m)	B7X1-032S
38 mm (1-1/2")	0.830" (21.1 mm)	1.067 in ² (688 mm ²)	112 kips (498 kN)	90.7 kips (404 kN)	3.76 lbs/ft (5.6 kg/m)	B7X1-038N
51 mm (2")	1.187" (30.1 mm)	1.795 in ² (1158 mm ²)	188 kips (837 kN)	152 kips (677 kN)	6.26 lbs/ft (9.3 kg/m)	B7X1-051N
76 mm (3")	1.890" (48.0 mm)	3.880 in ² (2503 mm ²)	407 kips (1811 kN)	329 kips (1466 kN)	13.79 lbs/ft (20.5 kg/m)	B7X1-076N

B7Y1 Non-Domestic Hollow Injection Bar

Bar Designation & Outer Diameter	Average Inner Diameter	Minimum Net Area Through Threads	Minimum Ultimate Strength	Minimum Yield Strength	Nominal Weight	Part Number
T30S - 30 mm (1.18")	11 mm (0.43")	0.662 in ² (427 mm ²)	71.9 kips (320 kN)	58.5 kips (260 kN)	2.42 lbs/ft (3.6 Kg/M)	B7Y1-030S
T40N - 40 mm (1.57")	20 mm (0.79")	1.046 in ² (675 mm ²)	121 kips (539 kN)	96.7 kips (430 kN)	4.23 lbs/ft (6.3 Kg/M)	B7Y1-040N
T40S - 40 mm (1.57")	16 mm (0.63")	1.222 in ² (788 mm ²)	148 kips (660 kN)	118 kips (525 kN)	4.84 lbs/ft (7.2 Kg/M)	B7Y1-040S
T52N - 52 mm (2.05")	24 mm (0.94")	1.874 in ² (1209 mm ²)	209 kips (929 kN)	164 kips (730 kN)	6.92 lbs/ft (10.3 Kg/M)	B7Y1-052N
* T73N - 73 mm (2.87")	53 mm (2.08")	2.5 in ² (1615 mm ²)	260 kips (1160 kN)	218 kips (970 kN)	8.9 lbs/ft (13.2 Kg/M)	B7Y1-073N *
T76S - 76 mm (2.99")	45 mm (1.77")	3.891 in ² (2510 mm ²)	427 kips (1900 kN)	337 kips (1500 kN)	13.23 lbs/ft (19.7 Kg/M)	B7Y1-076S
* T103N - 103 mm (4.06")	78 mm (3.07")	4.87 in ² (3140 mm ²)	510 kips (2270 kN)	405 kips (1800 kN)	17.0 lbs/ft (25.3 Kg/M)	B7Y1-103N *
* T130N - 130 mm (5.12")	60 mm (2.36")	16.2 in ² (10452 mm ²)	1785 kips (7940 kN)	1180 kips (5250 kN)	50.4 lbs/ft (78 Kg/M)	B7Y1-130N *

* Diameter available on special order. Contact your Williams representative for fastener and drill bit information.



Accessories

Threaded Bar Profile

The Hollow Injection Bar is a high strength, impact resistant heavy wall steel tubing conforming to ASTM A519 or A513 and is continuously threaded over its entire length with a heavy duty left hand thread/deformation pattern. The steel tubing provides maximum flow with minimum resistance during high pressure flushing and grouting operations. The thread form (similar for all diameters) is a unique Williams feature that provides a lower thread pitch angle to provide easier coupling disengagement without "locking up", than conventional rope threads during drilling operations. This thread form provides more surface area and thread/deformations per unit length for superior bond capabilities over that of competitive drill steel thread forms. The bar's thread/deformation pattern has also shown to exceed the bond characteristics of ASTM A615 reinforcing steel. The lower thread angle allows the installed anchor to be torque-tensioned. The Geo-Drill Injection Anchor system is available with enhanced corrosion protection with hot-dip galvanized/epoxy coated bars and components. Installation adapters for the Geo-Drill Injection Anchors are available for all drill rigs.

Couplings

The Hollow Injection Bar Couplings have a unique tapered center stop which seals the Injection Bar connection to minimize grout leakage during simultaneous grouting and drilling operations. The internal stop design also assures a full positive thread connection in both Injection Bar ends while providing a matching end bearing between bars that reduces percussion energy loss to the drill bit. The couplings are machined from ASTM A29 grade C1045 high strength steel to provide 100% ultimate tensile or compression strength capacity of the installed anchorage. The coupling OD is tapered on both ends to allow drill cuttings and grout displacement during drilling while the ID has internal chamfers to assist alignment and connection of the bars. The Non-Domestic Hollow Injection Bar Couplings do not contain a tapered center stop, but instead have an o-ring gasket to minimize grout leakage.



Stop-Type Coupling

Bar	Outside Diameter	Overall Length	Part Number
32 mm	1-5/8" (41 mm)	6-1/4" (159 mm)	B7X2-032
38 mm	2" (51 mm)	7-5/8" (194 mm)	B7X2-038
51 mm	2-5/8" (67 mm)	8-1/2" (216 mm)	B7X2-051
76 mm	3-7/8" (98 mm)	9-7/8" (251 mm)	B7X2-076
T30	1-1/2" (38 mm)	4-1/8" (105 mm)	B7Y2-030
T40	2-1/8" (54 mm)	5-1/2" (140 mm)	B7Y2-040
T52	2-3/4" (70 mm)	6-1/4" (159 mm)	B7Y2-052
T76	3-3/4" (95 mm)	8-5/8" (219 mm)	B7Y2-076

Hex Nuts

The Hex Nuts designed exclusively for the Geo-Drill Injection Anchor system are a full 100% ultimate tension or compression strength component. They are manufactured from a high strength steel complying with ASTM A108.



Hex Nuts

Nominal Bar Diameter	Across Flats	Across Corners	Thickness	Part Number
32 mm (1-1/4")	1-3/4" (45 mm)	2.0" (51 mm)	1-3/4" (44 mm)	B7X3-032
38 mm (1-1/2")	2" (51 mm)	2.3" (59 mm)	2" (51 mm)	B7X3-038
51 mm (2")	3" (76 mm)	3.5" (88 mm)	3-1/2" (89 mm)	B7X3-051
76 mm (3")	4-1/4" (108 mm)	4.9" (125 mm)	3-3/4" (95 mm)	B7X3-076
T30	1-7/8" (46 mm)	2.2" (59 mm)	1-3/8" (35 mm)	B7Y3-030
T40	2-1/2" (65 mm)	2.9" (73 mm)	2" (51 mm)	B7Y3-040
T52	3-1/8" (80 mm)	3.6" (92 mm)	2-3/4" (70 mm)	B7Y3-052
T76	4" (102 mm)	4.6" (117 mm)	3-1/8" (80 mm)	B7Y3-076

R8M Beveled Washers

Bar	Degree of Bevel	Outside Diameter	Inside Diameter	Maximum Thickness	Minimum Thickness	Part Number
32 mm & T30	15°	2-13/16" (71 mm)	1-5/16" (33 mm)	1" (25 mm)	5/16" (8 mm)	R8M-09S
38 mm	15°	3-3/8" (86 mm)	1-3/4" (45 mm)	1-1/4" (32 mm)	3/8" (10 mm)	R8M-12S*38
T40	15°	3-1/2" (89 mm)	2" (51 mm)	1-1/4" (32 mm)	3/8" (10 mm)	R8M-13S
51 mm & T52	15°	5-1/4" (133 mm)	2-9/32" (58 mm)	1-5/8" (41 mm)	7/16" (11 mm)	R8M-16-150
76 mm & T76	15°	6" (152 mm)	3-1/2" (89 mm)	2-7/64" (54 mm)	1/2" (13 mm)	R8M-24B7X

Beveled washers must be used in conjunction with hardened washer.

R9F Hardened Washers

Bar	Outside Diameter	Inside Diameter	Thickness	Part Number
32 mm & T30	2-1/2" (64 mm)	1-3/8" (35 mm)	5/32" (4 mm)	R9F-10-436
38 mm & T40	3" (76 mm)	1-5/8" (41 mm)	5/32" (4 mm)	R9F-12-436
51 mm & T52	3-3/4" (95 mm)	2-1/8" (54 mm)	7/32" (6 mm)	R9F-16-436
76 mm & T76	5-1/2" (140 mm)	3-1/8" (80 mm)	9/32" (7 mm)	R9F-24-436

B7XC Centralizers

The bar can be centralized in the drill hole on 10' centers by attaching a steel centralizer in front of the coupling during the drilling operation. Available plain or hot dip galvanized to ASTM A123. State drill hole diameter and bar size when ordering.





Accessories

B7XB Drill Bits



HC Hardened Bit

Hardened cross cut drill bit, suitable for the majority of applications including narrow bands of soft rock.

Soil Types: Fills and Medium Dense Gravels



CC Carbide Bit

Tungsten carbide cross-cut drill bit. Excellent choice for majority of granular soils with mixed hard formations.

Soil Types: Fills, Gravels, Shale & Seamy Rock Formations



SB Sand/Clay Bit

Two stage cross cut drill bit, suitable for loose to medium dense ground and fills.

Soil Types: Sand, Clay and Light Gravels



BB Button Bit

Tungsten carbide hemispherical button drill bit for moderately strong to strong rock, boulders and rubble.

Rock Types: Mudstone, Limestone, and Granite



CB Cobble Bit

Offset face cross cut drill bit suitable for drilling in cobbles with silt and gravel as well as sedimentary bedrock material.

Nominal Bar Diameter	Available Drill Bit Diameters				
	HC	CC	SB	BB	CB
32 mm (1-1/4")	2" (51 mm)	2" (51 mm)	5" (127 mm)	2-1/2" (65 mm)	4" (102 mm)
	2-1/2" (65 mm)	2-1/2" (65 mm)		3" (76 mm)	
	3" (76 mm)	3" (76 mm)		3-1/2" (89 mm)	
	3-1/2" (89 mm)	3-1/2" (89 mm)		4" (102 mm)	
	4" (102 mm)	4" (102 mm)			
38 mm (1-1/2")	2-1/2" (65 mm)	2-1/2" (65 mm)	5" (127 mm)	2-1/2" (65 mm)	4" (102 mm)
	3" (76 mm)	3" (76 mm)		3" (76 mm)	
	3-1/2" (89 mm)	3-1/2" (89 mm)		3-1/2" (89 mm)	
	T30	4" (102 mm)	4" (102 mm)		
T40	4-1/2" (114 mm)	6" (152 mm)	5" (127 mm)		
51 mm (2")		3" (76 mm)	6" (152 mm)	3" (76 mm)	4-3/4" (121 mm)
		3-1/2" (90 mm)		3-1/2" (90 mm)	
		4" (102 mm)	8" (203 mm)	4" (102 mm)	6" (152 mm)
		4-1/2" (114 mm)		5" (127 mm)	
		5" (127 mm)		5" (127 mm)	
T52	4" (102 mm)	7" (178 mm)			
76 mm (3")		5" (125 mm)	7" (178 mm)	5" (125 mm)	
		6" (152 mm)	10" (254 mm)	6" (152 mm)	
	T76	7" (175 mm)			

Applications

Soil Nails

Soil Nails are non-tensioned, in-situ reinforcement for the stability of excavations and embankments in top-down construction. The Williams Geo-Drill Injection Anchor System is an ideal choice for soil nailing in difficult soils as it offers high installation rates. Hollow bar soil nails have been used extensively on private and select DOT permanent soil nail walls for years. With the 2015 edition of the FHWA Geotechnical Engineering Circular #7, hollow bar soil nails are specifically addressed and allowed for use in non-corrosive ground conditions. Consult your Williams' Technical Representative for more information.

Prestressed Ground Anchors

Williams Geo-Drill Injection Anchors can be used as a choice for pre-tensioned anchors in loose or collapsing soils without the need for a casing. A free length must be installed onto the anchor if the project specifications call for a pre-tension load to be applied from the bond length. Please consult with a Williams specialist for suggestions to properly attach a free length sleeve. Note to Designer: Consult with Williams for an appropriate level of corrosion protection if prestressed ground anchors are intended to be used for a permanent application.

Micropiles

Williams Hollow Injection Bar offer an excellent choice for micropiles in difficult ground conditions where open-hole drilling isn't possible. The continuously threaded bar profile lends itself perfectly for restricted headroom applications because the bar can be cut and coupled at any length. The FHWA has approved hollow bar anchors for permanent use in micropile applications.

Tunnel Spiles and Forepoling

The Geo-Drill Injection Anchor System is often used for spiling in NATM tunneling. Spiles are continuously drilled and grouted pre-support reinforcement to enable the heading of a tunnel to advance without the risk of falling debris. The anchors can also be used as face stabilization of portals.

Limitations of System

In general, Williams recommends using the Geo-Drill Injection Anchor System in difficult soils that do not allow for open-hole drilling. Ground conditions featuring large voids or the presence of an artesian water condition are generally not suitable for a drilled and grouted hollow bar. In hard rock, conventional DTH (Down the Hole Hammers) in open-hole drilling offer a more efficient alternative. In all such cases, Williams offers solutions in their complete line of solid bar anchor systems and multi-strand tendon systems.

U.S. CUSTOMARY (INCH-POUND) WIRE SIZES AND AREAS
TABLE 5 - SECTIONAL AREAS OF WELDED WIRE REINFORCEMENT

Wire Size Number* (area of steel x 100)	Nominal Diameter Inches	Nominal Weight Lbs./Lin. Ft.	Area in Sq. In. Per Ft. Of Width For Various Spacing					
			Center-To-Center Spacing					
			3"	4"	6"	12"	18"	
Plain								
W45	.757	1.530	1.80	1.35	.90	.45	.30	
W34	.658	1.160	1.36	1.02	.68	.34	.23	
W31	.628	1.054	1.24	.93	.62	.31	.21	
W25	.564	.850	1.00	.75	.50	.25	.17	
W23	.541	.782	.92	.69	.46	.23	.15	
W20	.505	.680	.80	.60	.40	.20	.13	
W18	.479	.612	.72	.54	.36	.18	.12	
W16	.451	.544	.64	.48	.32	.16	.11	
W15	.437	.510	.60	.45	.30	.15	.10	
W14	.422	.476	.56	.420	.28	.14	.090	
W12	.391	.408	.48	.360	.24	.12	.080	
W11	.374	.374	.44	.330	.22	.11	.073	
W10.5	.366	.357	.42	.315	.21	.105	.070	
W10	.357	.340	.40	.300	.20	.10	.068	
W9.5	.348	.323	.38	.285	.19	.095	.063	
W9	.338	.306	.36	.270	.18	.090	.060	
W8.5	.329	.329	.34	.255	.17	.085	.057	
W8	.319	.272	.32	.240	.16	.080	.053	
W7.5	.309	.309	.30	.225	.15	.075	.050	
W7	.299	.238	.28	.210	.14	.070	.047	
W6.5	.288	.221	.26	.195	.13	.065	.043	
W6	.276	.204	.24	.180	.12	.060	.040	
W5.5	.265	.187	.22	.165	.11	.055	.037	
W5	.252	.170	.20	.150	.10	.050	.033	
W4.5	.239	.153	.18	.135	.09	.045		
W4	.226	.136	.16	.12	.08	.040		
W3.5	.211	.119	.14	.105	.07	.035		
W3	.195	.102	.12	.09	.06	.030		
W2.9	.192	.098	.116	.087	.058	.029		
W2.5	.178	.085	.100	.075	.050	.025		
W2.1	.162	.070	.084	.063	.042	.021		
W2	.160	.068	.080	.060	.040	.020		
W1.5	.138	.051	.060	.045	.030	.015		
W1.4	.134	.049	.056	.042	.028	.014		

Examples Using Various Minimum Yield Strengths for Economy - Consider:

- Grade 60 wire by style 12X12 - W31/W31 (Standard)
- Grade 75 wire by style 12X12 - W25/W25 (20% savings by weight & steel area)
- Grade 80 wire by style 12X12 - W23/W23 (25% savings by weight & steel area)

Note: The above listing of plain wire sizes represents wires normally selected to manufacture welded wire reinforcement styles to specific areas of reinforcement. Wires may be deformed using prefix D, except where only W is required on building codes (usually less than W4). Wire sizes other than those listed above may be available if the quantity required is sufficient to justify manufacture.

*The number following the prefix W identifies the cross-sectional area of the wire in hundredths of a square inch.

The nominal diameter of a deformed wire is equivalent to the diameter of a plain wire having the same weight per foot as the deformed-wire.

Refer to ACI 318 for The ACI Building Code requirements for tension development lengths and tension lap splices of welded wire reinforcement. For additional information see Welded Wire Reinforcement Manual of Standard Practice and Structural Welded Wire Reinforcement Detailing Manual, published by the Wire Reinforcement Institute.

Prefabricated Drainage Material

SITEDRAIN™ STRIP 6600 PREFABRICATED STRIP DRAIN



PRODUCT OVERVIEW

SITEDRAIN Strip 6600 geocomposite strip drain products are composed of a dimpled polymeric perforated core fully wrapped in a nonwoven geotextile. The geotextile allows water to pass through while retaining backfill materials. The perforated core allows water collection from all sides and provides a continuous flow path to designated drainage exits.

SITEDRAIN Strip 6600 products provide a value engineered alternative to perforated pipe and aggregate subsurface drainage systems requiring moderate strength, high flow capacity, and a geotextile meeting AASHTO M288 Class 2 subsurface drainage requirements.

PROPERTY ¹	TEST METHOD	UNIT OF MEASURE	Typical Value	MARV
GEOTEXTILE				
Material ²			PP, NPNW	PP, NPNW
Survivability	AASHTO M288	Class	2	2
Grab Tensile Strength	ASTM D4632	lbs	195	160
		N	867	712
Grab Elongation	ASTM D4632	%	60	50
CBR Puncture	ASTM D6241	lbs	505	410
		N	2,246	1,824
Trapezoidal Tear	ASTM D4533	lbs	85	60
		N	378	267
UV Resistance	ASTM D4355	% / 500 Hrs	70	70
Apparent Opening Size (AOS) ³	ASTM D4751	sieve	70	70
		mm	0.212	0.212
Permittivity	ASTM D4491	sec ⁻¹	2.1	1.5
Water Flow Rate	ASTM D4491	gpm / ft ²	155	110
		Lpm / m ²	6,315	4,482
CORE				
Compressive Strength	ASTM D6364	psf	6,000	-
	ASTM D1621	kPa	287	-
Thickness	ASTM D5199	in	1.0	-
		mm	25.4	-
In-Plane Flow Rate ⁴	ASTM D4716	gpm/ft	21	-
		Lpm/m	261	-

MODEL	WIDTH	ROLL LENGTH	ROLL WEIGHT	ITEM CODE
6606	6"	150'	27 lbs	10450
6612	12"	150'	51 lbs	10460
6612	12"	500'	170 lbs	11190
6618	18"	150'	72 lbs	10470
6618	18"	500'	240 lbs	11200
6624	24"	150'	94 lbs	10480
6624	24"	500'	313 lbs	11210
6636	36"	100'	94 lbs	10490

¹ Unless otherwise noted, all physical and performance properties listed are Typical Value or Minimum Average Roll Value (MARV) as defined in ASTM D4439.

² PP = Polypropylene; NPNW = Needle-Punched Nonwoven; WM = Woven Monofilament; SBNW = Spunbonded Nonwoven

³ Values for AOS represent Maximum Average Roll Value (MaxARV).

⁴ In-plane flow rate measured at 3,600 psf (172 kPa) compressive load and a hydraulic gradient of 0.1.

All technical information contained in this document is accurate as of publication. AWD reserves the right to make changes to products and literature without notice. Please refer to our website for the most current technical information available.

American Wick Drain • 1209 Airport Road, Monroe, NC 28110 USA • TF: +1.800.242.9425 • PH: +1.704.238.9200 • EMAIL: info@awd-usa.com • WEB: awd-usa.com

2018 SO 516600

Appendix E - Micropile Testing

Testing Procedure and Equipment

The testing procedure for micropile elements is described as following: The reaction frame will be sufficiently rigid and of adequate dimensions so that excessive deformation of the testing equipment does not occur. The configuration of the testing apparatus will be designed so that the jack, bearing plates, and stressing anchorage will not need to be repositioned during a test.

The load will be applied with a hydraulic jack and measured with a pressure gauge. The pressure gauge will be graduated in 100 psi increments or less. Ram travel will be sufficient to allow the test to be done without resetting the equipment. All rams, pressure gauges, and pumps will have been calibrated with each other within the last 12 months by an independent accredited laboratory. Calibrated jacks, gages, and pumps will have identifiable serial numbers to insure traceability to calibration tests.

Movement of the pile head shall be measured with a dial gauge capable of measuring to the nearest 0.001 inch. The gauge will be visually aligned to be parallel with the axis of the micropile and shall be supported independently of the jack or reaction frame.

Testing shall be performed by incrementally loading the test piles per to the subsequent loading schedules. The test load shall be monitored by a jack pressure gauge with sensitivity and range meeting the requirements of pressure gauges used for pile testing. The micropile movements shall be recorded at each load increment.

Testing on Micropiles

All micropile testing will be performed in tension and on five percent of production elements. Test locations will be selected at random, and all testing will occur on production elements installed within the repair limits. Testing will be completed based on the information provided above and in the construction drawings.

Appendix F - Construction Details

BLUFF STABILIZATION PLANS

LAS BRISAS CONDOMINIUMS

CITY OF SOLANA BEACH, CA
LAS BRISAS HOA



VICINITY MAP

(NOT TO SCALE)

SHEET INDEX

NO.	DESCRIPTION
C-01	COVER SHEET
C-02	GENERAL NOTES
C-03	GENERAL NOTES (CONT.)
C-04	EXISTING SITE & ACCESS PLAN
C-05	PROJECT SITE PLAN
C-06	SECTION VIEW - CUTOFF WALL
C-07	CUTOFF WALL DETAILS
C-08	MICROPILE ANCHOR DETAILS
C-09	MICROPILE CAP DETAILS
C-10	SECTION VIEW - RSS SYSTEM
C-11	PHASE II MITIGATION SECTION
C-12	MICROPILE TESTING DETAILS
C-13	DRILL LOGS

SHEET REVISIONS

DATE	DESCRIPTION	NO.
09/01/21	ISSUED FOR REVIEW	IF R
09/27/21	ISSUED FOR PERMIT	IF P

PROJECT NAME:

LAS BRISAS CONDOMINIUMS

SHEET TITLE:

COVER SHEET

DRAWN BY:

MAC

CHECKED BY:

JDR

DATE:

09/27/21

PROJECT NUMBER:

210487CA01

SHEET

C-01



Phone: 855.579.0536 | Fax: 970.246.7737
www.geostabilization.com



THIS DRAWING IS FURNISHED SOLELY FOR THE USE OF OR IN CONNECTION WITH THIS PROJECT AND THE PROPRIETARY INFORMATION SHOWN HEREON IS NOT TO BE TRANSMITTED TO ANY OTHER ORGANIZATION WITHOUT SPECIFIC AUTHORIZATION BY GEOSTABILIZATION INTERNATIONAL, LLC. THE DESIGN IS ONLY VALID IF CONSTRUCTED AND SUPERVISED BY GSI OR ITS AUTHORIZED SUBCONTRACTOR.

GENERAL NOTES:

- GSI WILL BE THE LEAD FOR JOB SITE CONDITIONS AND SAFETY DURING CONSTRUCTION HOURS. THE JOB SITE WILL BE KEPT REASONABLY SECURE TO DETER UNAUTHORIZED ENTRY OR TAMPERING. HOWEVER, THOSE WHO ENTER THE CONSTRUCTION ZONE WITHOUT ENTRY WILL BE CONSIDERED TO BE TRESPASSING.
- GSI WILL USE UTILITY ONE CALL SERVICES, REQUEST UTILITY MAPS, AND REQUEST POTHOLING AS NEEDED TO LOCATE AND MARK KNOWN UTILITIES.
 - DIG ALERT: DIAL 811, OR DIGALERT.ORG
 - CITY OF SOLANA BEACH PUBLIC WORKS: 858-720-2470
- AT THE END OF EACH WORK DAY GSI WILL LEAVE THE WORK AREA FREE OF HAZARDS, AND PROVIDE TEMPORARY SIGNS, WARNING DEVICES, AND/OR BARRICADES, AS NEEDED.
- GSI WILL KEEP RECORDS OF THE DRILLING CONDITIONS, GROUT MIX SPECIFIC GRAVITY AND OTHER NOTES ON THESE PLANS AS NEEDED TO PROVIDE AS-BUILT INFORMATION TO THE OWNER AFTER PROJECT COMPLETION.
- GSI UNDERSTANDS THE WORKING HOURS FOR THIS SITE TO BE 7:00 A.M. AND 7 P.M. EACH DAY, MONDAY THROUGH FRIDAY.
- GSI WILL NOTIFY THE CITY OF SOLANA BEACH AT (858) 720-2470, AT LEAST 24 HOURS BEFORE THE FIRST DAY OR THE PROJECT.

STANDARD REQUIREMENTS:

GSI WILL PERFORM THE WORK IN GENERAL ACCORDANCE WITH THE LATEST EDITION AND SUPPLEMENTS OF THE "STANDARD SPECIFICATIONS FOR PUBLIC WORKS CONSTRUCTION," SAN DIEGO REGIONAL STANDARD DRAWINGS AND CITY OF SOLANA BEACH ENGINEERING CONSTRUCTION STANDARDS.

ASSESSOR PARCEL NUMBERS	ADDRESSES
298-010-54-0001 THROUGH -36	135 S SIERRA AVE

EROSION CONTROL NOTES:

- GSI WILL PLACE SILT FENCE AT THE TOE OF THE SLOPE (TOP OF THE SEA WALL) TO LIMIT ERODED SOILS FROM REACHING THE PUBLIC BEACH.
- GSI WILL USE DIKES, BERMS OR TRENCHES TO LIMIT STORMWATER WATER FLOWING OVER CRESTS OF THE SLOPE.
- GSI WILL USE WATER AS NEEDED TO MINIMIZE AIR BORNE DUST ON THE SITE.

HOUSE KEEPING:

- THE SITE WILL BE ORGANIZED AND CLEAR OF ANY TRASH OR DEBRIS. ALL TRASH WILL BE PLACED IN A PROPER CONTAINER AND REMOVED AT THE END OF EACH WORK DAY.

SAFETY:

- ALL SAFETY PLANS FOR LIFTING, HEARING, DUST CONTROL, PPE ETC. WILL BE IN PLACE AND FOLLOWED ACCORDINGLY. PPE INCLUDES SAFETY VEST, STEEL TOED SHOES, HARD HAT, SAFETY GLASSES, RESPIRATOR DURING DUST PRODUCING ACTIVITIES, AND GLOVES.
- GSI WILL GENERATE A SITE SPECIFIC HEALTH AND SAFETY PLAN THAT MUST BE REVIEWED AND SIGNED BY ALL GSI EMPLOYEES, SUBCONTRACTORS, AND VISITORS TO THE SITE.
- GSI WILL LEAD A DAILY TAILGATE MEETING TO REVIEW JOB HAZARD ANALYSIS "JHA" FOR EACH OF THE DAYS ANTICIPATED TASKS.

EMPLOYEE CERTIFICATIONS:

- ACI SHOTCRETE NOZZLEMEN CERTIFICATION
- 10-HOUR OCCUPATIONAL SAFETY AND HEALTH TRAINING COURSE IN CONSTRUCTION SAFETY & HEALTH
- AMERICAN RED CROSS STANDARD FIRST AID TRAINING

ANTICIPATED CONSTRUCTION SEQUENCE/WORK SCHEDULE:

1. DELINEATE LIMITS OF STABILIZATION. NOTIFY LOCAL UTILITIES PROVIDERS TO LOCATE AND MARK POTENTIAL UNDERGROUND FACILITIES. DAYLIGHTING OF UTILITIES IN POTENTIAL CONFLICT, AS NECESSARY (BY OTHERS).
2. PREPARE THE WORK AREA FOR MICROPILE INSTALLATION AND CUTOFF WALL CONSTRUCTION:
 - 2.1. INSTALL EROSION CONTROL FENCE AT THE TOP OF THE EXISTING SEAWALL TO LIMIT SOIL EROSION DURING CONSTRUCTION.
 - 2.2. MINOR RE-SHAPING OF EXISTING SCARP AND SURROUNDING GRADES MAY BE NEEDED TO FACILITATE CONSTRUCTION OF THE MICROPILE CUTOFF WALL.
 - 2.3. MARK THE LOCATIONS OF THE PROPOSED STABILIZATION ELEMENTS WITH SURVEY MARKING PAINT.
3. INSTALLATION OF MICROPILE ELEMENTS. EACH ELEMENT WILL BE GROUTED DURING DRILLING UNLESS DIRECTED OTHERWISE BY GSI ENGINEER.
4. CONSTRUCT THE CUTOFF WALL:
 - 4.1. PLACE REINFORCING STEEL AND DRAIN STRIPS PER THESE DRAWINGS.
 - 4.2. USE WOOD OR SIMILAR FORMWORK ON THE NORTH SIDE OF THE CUTOFF WALL TO FACILITATE SHOTCRETE PLACEMENT.
 - 4.3. PLACE SHOTCRETE FROM THE BOTTOM UP TO THE REQUIRED THICKNESS DETAILED IN THESE PLANS.
5. PREPARE AREA NORTH OF THE CUTOFF WALL FOR REINFORCED SOIL SLOPE SYSTEM INSTALLATION. MINOR GRUBBING AND GRADING MAY BE NECESSARY.
6. INSTALL REINFORCED SOIL SLOPE SYSTEM IN LIFTS AS DETAILED IN THESE DRAWINGS AND PER THE MANUFACTURER INSTALLATION PROCEDURES.
7. SITE CLEANUP AND DEMOBILIZATION FROM SITE.
 - 7.1. CONCRETE, GROUT, AND OTHER CONSTRUCTION DEBRIS WILL BE REMOVED PERIODICALLY THROUGHOUT THE WORK.
 - 7.2. FINAL CLEANUP OF THE SITE TO INCLUDE REASONABLE HAND CLEANING METHODS LIKE SWEEPING, SPRAYING WITH WATER AND REMOVAL OF TRASH AND DEBRIS. MAJOR LANDSCAPING SHOULD NOT BE NEEDED IF PROPER ACCESS IS GRANTED TO GSI THROUGHOUT THE PROJECT.

SIZE AND TYPE OF STABILIZATION ELEMENTS:

- THE MICROPILE ELEMENTS SHALL CONSIST OF 51mm NOMINAL DIAMETER, SELF-DRILLING HOLLOW BAR. SACRIFICIAL DRILL BITS WILL BE ATTACHED TO THE STABILIZATION ELEMENT PRIOR TO INSTALLATION.
- SACRIFICIAL DRILL BITS ARE NOT PERMANENTLY INCORPORATED INTO THE PROJECT AND MAY BE REMOVED AFTER DRILLING OR LEFT AT THE PROJECT FOR THE CONTRACTOR'S CONVENIENCE. SACRIFICIAL DRILL BITS ARE NOT END PRODUCTS. SACRIFICIAL DRILL BITS ARE NOT PRODUCED IN THE UNITED STATES.
- GSI ENGINEER MAY ELECT TO MODIFY THE TYPE OF STABILIZATION ELEMENT, LENGTH OR INSTALLATION METHOD, DEPENDING ON ACTUAL DRILLING CONDITIONS.

FACING AND DRAINAGE SYSTEM:

- DRAIN STRIPS WILL BE PROVIDED AND INSTALLED APPROX. EVERY SIX-FEET ALONG THE NORTH SIDE OF THE CUTOFF WALL. THE DRAIN STRIPS SHALL BE PLACED WITH THE GEOTEXTILE SIDE AGAINST THE FORMWORK.
- DRAIN STRIPS WILL BE CONTINUOUS AND ANY SPLICES SHALL BE MADE WITH A ONE-FOOT MINIMUM OVERLAP SUCH THAT THE FLOW OF WATER IS NOT IMPEDED.
- DRAIN STRIPS SHALL EXTEND BEYOND THE FACE OF THE SHOTCRETE AT THE DOWNHILL FACE.
- DRAIN STRIPS SHALL BE MINIMUM 12" WIDE.

REINFORCING STEEL PLACEMENT:

- REINFORCING STEEL FOR THIS PROJECT SHALL BE EPOXY COATED OR GALVANIZED.
- WELDED WIRE MESH WILL BE PLACED ON BOTH SIDES OF THE EXTENDED 51mm MICROPILES AS SHOWN IN THESE DRAWINGS.
- NO. 5 REBAR WILL BE TIED TO THE SOUTH WIRE MESH. FOLLOW SPACING AND SPLICE LENGTHS AS SHOWN IN THESE DRAWINGS.
- NO. 5 REBAR WILL ALSO BE USED FOR THE MICROPILE CAP. FOLLOW SPACING AND SPLICE LENGTHS AS SHOWN IN THESE DRAWINGS.

MICROPILE CAP PLATES:

- 6" X 6" X 1/2" STEEL BEARING PLATES WILL BE PLACED OVER THE MICROPILES IN THE MICROPILE CAP AND ATTACHED WITH A HEX NUT TOP AND BOTTOM. IF THE MICROPILES EXTEND BEYOND THE TOP HEX NUTS, THEY WILL BE TRIMMED.

REINFORCED SOIL SLOPE (RSS) SYSTEM:

HIGH PERFORMANCE TURF REINFORCEMENT MAT (HPTRM)

- MATERIAL IS THREE-DIMENSIONAL, LOFTY WOVEN POLYPROPYLENE HPTRM
- MATRIX COMPOSED OF TRILOBAL MONOFILAMENT YARNS WOVEN INTO UNIFORM CONFIGURATION OF RESILIENT PYRAMID-LIKE PROJECTIONS THAT MINIMIZE WATERING REQUIREMENTS WHILE ENHANCING VEGETATION ESTABLISHMENT.
- MUST BE A HOMOGENEOUS MATRIX, AND NOT COMPRISED OF LAYERS, COMPOSITES, OR DISCONTINUOUS MATERIALS, OR OTHERWISE LOOSELY HELD TOGETHER BY STITCHED OR GLUED NETTING.
- THE HPTRM SHOULD MEET THE FOLLOWING VALUES:

PROPERTY	TEST METHOD	UNITS	MINIMUM REQUIREMENT
THICKNESS	ASTM D6525	IN	0.4
LIGHT PENETRATION	ASTM D6567	%	10
TENSILE STRENGTH	ASTM D6818	LB/FT	4000 X 3000
TENSILE ELONGATION	ASTM D6818	%	40 X 35
RESILIENCY	ASTM D6524	%	80
FLEXIBILITY	ASTM D6575	IN-LB	0.534
UV RESISTANCE	ASTM 4355	%	90 AT 6000 hrs

- WOOD OR PLASTIC STAKES, OR STEEL PINS ARE USED TO PIN-DOWN THE GEOTEXTILE NEAR THE BACK OF THE REINFORCEMENT ZONE TO HOLD THE GEOTEXTILE TAUT WHILE ALIGNING THE WALL FACE AND PLACING SOIL BACKFILL. THESE ARE INSTALLED AS NEEDED ALONG THE HPTRM, BUT AT A FREQUENCY NO LESS THAN 1 PER 6 LINEAL FEET. THE STAKES OR PINS SHALL BE 9 TO 12 IN LONG.
- BACKFILL WILL COMPRISE GENERAL FILL WITH A UNIFIED SOIL CLASSIFICATION SYSTEM DESIGNATION OF SILTY SAND (SM).
 - THE SM MATERIAL WILL CONSIST OF INERT EARTH MATERIALS WITH LESS THAN 3% ORGANICS OR OTHER DELETERIOUS SUBSTANCES.
 - FILL WILL BE PLACED IN UNIFORM, MAXIMUM 12-INCH LIFTS.
 - FILL IN THE UPPER 12 INCHES OF THE GRADED SLOPE FACE WILL NOT BE COMPACTED DUE TO LACK OF CONFINEMENT.
 - FILL BEHIND THE UPPER 12 INCHES OF THE GRADED SLOPE FACE WILL BE COMPACTED TO AT LEAST 90% OF THE MATERIALS MAXIMUM DRY DENSITY AND BE UNIFORMLY MOISTURE CONDITIONED TO AT LEAST THE OPTIMUM MOISTURE CONTENT AS DETERMINED BY ASTM D1557.

SHEET REVISIONS

DATE	DESCRIPTION	NO
09/01/21	ISSUED FOR REVIEW	IFR
09/27/21	ISSUED FOR PERMIT	IFP

PROJECT NAME:
LAS BRISAS CONDOMINIUMS

SHEET TITLE:
GENERAL NOTES

THIS DRAWING IS FURNISHED SOLELY FOR THE USE OF OR IN CONNECTION WITH THIS PROJECT AND THE PROPRIETARY INFORMATION SHOWN HEREON IS NOT TO BE TRANSMITTED TO ANY OTHER ORGANIZATION WITHOUT SPECIFIC AUTHORIZATION BY GEOSTABILIZATION INTERNATIONAL (GSI). THE DESIGN IS ONLY VALID IF CONSTRUCTED AND SUPERVISED BY GSI OR ITS AUTHORIZED SUBCONTRACTOR.

DRAWN BY: MAC	CHECKED BY: JDR	DATE: 09/27/21	PROJECT NUMBER: 210487CA01	SHEET C-02
-------------------------	---------------------------	--------------------------	--------------------------------------	----------------------



Phone: 855.579.0536 | Fax: 970.245.7737
www.geostabilization.com



C:\Users\robson\OneDrive\Documents\Projects\210487CA01 - Las Brisas Condominiums\Drawings\210487CA01-C-02.dwg 9/20/21 4:11 PM

RSS ANCHOR DETAILS

TYPE B3 ANCHOR PROPERTIES

Component	Materials	Material Composition	Physical Properties
Anchor Head	Hot Dip Galvanized Ductile Iron		6.43 in x 1.84 in x 2.36 in (163.3 mm x 46.7 mm x 59.9 mm) Bearing Area: 10.3 in ² (66.5 cm ²)
Cable Tendon	Galvanized Steel		Diameter: 0.1875 in (4.8 mm)
Lower Termination	Aluminum		Length: 0.65 in (16.5 mm), Wall Thickness: 0.11 in (2.8 mm)
Load Bearing Plate	Zinc-Aluminum		5.98 in x 6.6 in x 0.75 in (151.9 mm x 167.6 mm x 19.1 mm) Bearing Area: 17.43 in ² (112.5 cm ²)
Top Termination	Zinc-Aluminum		Circumferential Tripple Wedge Grip Assembly to Eliminate Cable Pinch Points Grip to Cable Contact Surface Area: 0.505 in ² (3.3 cm ²) Grip to Cable Contact Ratio: 97% of Cable Diameter
Performance Properties			
Ultimate Assembly Strength	2800 lb (12.46 kN)	Typical Working Load	2000 lb (8.9 kN)
Ultimate Cable Strength	3700 lb (16.46 kN)	Embedment Depth	6-12 ft (1.83-3.66 m)

SHOTCRETE MIX DESIGN:

- SHOTCRETE SHALL COMPLY WITH THE REQUIREMENTS OF ACI 506.2, "SPECIFICATIONS FOR MATERIALS, PROPORTIONING AND APPLICATION OF SHOTCRETE", EXCEPT AS OTHERWISE SPECIFIED. SHOTCRETING CONSISTS OF APPLYING ONE OR MORE LAYERS OF CONCRETE CONVEYED THROUGH A HOSE PNEUMATICALLY PROJECTED AT A HIGH VELOCITY AGAINST A PREPARED SURFACE.
- THE WET-MIX PROCESS CONSISTS OF THOROUGHLY MIXING ALL THE INGREDIENTS, INTRODUCING THE MIXTURE INTO THE DELIVERY EQUIPMENT AND DELIVERING IT, BY POSITIVE DISPLACEMENT, TO THE NOZZLE. AIR JET THE WET-MIX SHOTCRETE FROM THE NOZZLE AT HIGH VELOCITY ONTO THE SURFACE.
- GSI STANDARD SHOTCRETE MIX DESIGN SHALL BE USED UNLESS SHOTCRETE TEMPERATURES ARE ANTICIPATED TO REACH AND/OR EXCEED 85°F. IN THIS EVENT, GSI HOT WEATHER MIX MAY BE USED. SET TIME CONTROLLING ADDITIVES (I.E. HYDRATION STABILIZERS, RETARDERS) MAY BE USED PER THE MANUFACTURER SPECIFICATIONS AND UNDER THE DIRECTION OF A GSI ENGINEER.

GSI STANDARD SHOTCRETE MIX DESIGN (PER YD³)		
MATERIAL	DESCRIPTION	WEIGHT (LBS.)
AGGREGATE NO. 1	3/8" ROCK, AASHTO M80, CLASS B	650
AGGREGATE NO. 2	CONCRETE SAND, CLEAN, NATURAL	1800
AIR	6% TOTAL	--
WATER	CLEAN AND POTABLE	300
FLY ASH	TYPE F OR C	150
CEMENT	TYPE V	750
TOTAL	--	3710

GSI HOT WEATHER SHOTCRETE MIX DESIGN (PER YD³)		
MATERIAL	DESCRIPTION	WEIGHT (LBS.)
AGGREGATE NO. 1	3/8" ROCK, AASHTO M80, CLASS B	600
AGGREGATE NO. 2	CONCRETE SAND, CLEAN, NATURAL	1800
AIR	6% TOTAL	--
WATER	CLEAN AND POTABLE	315
FLY ASH	TYPE F OR C	300
CEMENT	TYPE V	700
TOTAL	--	3710

SHOTCRETE APPLICATION:

- SHOTCRETE APPLICATION WILL GENERALLY COMPLY WITH ACI 506.2-13 UNLESS DIRECTED BY GSI ENGINEER OR THEIR DESIGNATED REPRESENTATIVE.
- SHOTCRETE WILL BE PLACED FROM THE LOWER PART OF THE AREA UPWARDS TO PREVENT ACCUMULATION OF REBOUND. THE NOZZLE WILL BE ORIENTED A PROPER DISTANCE FROM AND APPROXIMATELY PERPENDICULAR TO THE WORKING FACE SO THAT REBOUND WILL BE MINIMAL AND COMPACTION WILL BE MAXIMIZED.
- CARE WILL BE TAKEN WHILE ENCASING REINFORCING STEEL AND MESH TO KEEP THE FRONT FACE OF THE REINFORCEMENT CLEAN DURING PLACEMENT OPERATIONS, SO THAT SHOTCRETE BUILDS UP FROM BEHIND, TO ENCASE THE REINFORCEMENT AND PREVENT VOIDS OR POCKETS FROM FORMING.
- SHOTCRETE THICKNESS TOLERANCE SHALL BE MINUS ONE INCH - PLUS TWO INCHES.

GROUT MIX DESIGN:

- STANDARD GROUT MIX DESIGN TO BE USED IN SOIL DRILLING.
- IF SLOWER DRILLING IS EXPERIENCED WHILE DRILLING IN ROCK GSI ENGINEERS MAY APPROVE USE OF DRILLING GROUT MIX DESIGN. UPON COMPLETION OF DRILLING TO SPECIFIED DEPTH WITH DRILLING GROUT MIX HOLE SHOULD BE FLUSHED WITH STANDARD GROUT MIX AND NAIL HOLE SWABBED TO AID IN DRILLING GROUT MIX REPLACEMENT.
- IF VOIDS ARE ENCOUNTERED AND GROUT LOSS IS EXPERIENCED CONTACT GSI ENGINEERS AND CUT OFF GROUT PUMPING FOR THAT ELEMENT WHEN DRILLING DEPTH IS REACHED AND A TOTAL OF 3 BAGS OF GROUT SLURRY PER 10' STICK OF BAR HAS BEEN USED.
- THE GROUT WILL BE A TYPE III/IV PORTLAND CEMENT. THE WATER/CEMENT RATIO WILL BE 0.5 TO 0.6. NO ADDITIONAL AGGREGATE OR ADMIXTURES WILL BE ADDED TO THE GROUT.

STANDARD GROUT MIX DESIGN			
MATERIAL	WEIGHT (LBS.)	VOLUME (FT ³)	FIELD UNIT VOLUME
WATER	235-282	3.8-4.5	28 - 34 GALLONS
CEMENT (TYPE I/II)	470	2.4	5 BAGS (94 LBS.)
TOTAL UNIT	705 - 752	6.1 - 6.9	--
W/C RATIO	--	--	0.5 - 0.6
SPECIFIC GRAVITY	--	--	1.84 - 1.75

DRILLING GROUT MIX DESIGN			
MATERIAL	WEIGHT (LBS.)	VOLUME (FT ³)	FIELD UNIT VOLUME
WATER	235-282	3.8-4.5	28 - 34 GALLONS
CEMENT (TYPE I/II)	188	0.9	2 BAGS (94 LBS.)
TOTAL UNIT	423 - 470	4.7 - 5.5	--
W/C RATIO	--	--	1.25 - 1.5
SPECIFIC GRAVITY	--	--	1.44 - 1.38

QUALITY CONTROL:

- GSI WILL CONDUCT OR OBTAIN QUALIFIED PERSONNEL TO CONDUCT THE FOLLOWING QUALITY CONTROL TESTING DURING THE PROJECT.

QUALITY CONTROL SCHEDULE		
DESCRIPTION	FREQUENCY	REFERENCE/ CRITERIA
DILL LOGS	EVERY MICROPILE	RECORD DATA PER SHEET C-14
PROOF NAIL TEST	5% OF PRODUCTION NAILS, TEST AFTER 48 HRS	FHWA 05-039, 2005
MUD BALANCE READINGS (SPECIFIC GRAVITY)	ONCE EACH DAY OF GROUTING	SEE SHEET C-03 & C-14 FOR MIX DESIGN AND DATA LOG
GROUT CUBES	1 SET OF 3 CUBES PER EVERY 10 PILES INSTALLED	ASTM C-109/AASHTO T106. 3, 7 & 28 DAY STRENGTH. 4000 PSI 28-DAY.
SHOTCRETE PANELS	2 PRODUCTION PANELS THROUGHOUT PROJECT	ASTM C1140, 1500 PSI. 3, 7 & 28 DAY STRENGTH. 5000 PSI 28-DAY.

SHEET REVISIONS

DATE	DESCRIPTION	NO
09/01/21	ISSUED FOR REVIEW	IFR
09/27/21	ISSUED FOR PERMIT	IFP

PROJECT NAME:

LAS BRISAS CONDOMINIUMS

SHEET TITLE:

GENERAL NOTES (CONT.)

DRAWN BY:

MAC

CHECKED BY:

JDR

DATE:

09/27/21

PROJECT NUMBER:

210487CA01

SHEET

C-03



Phone: 855.579.0536 | Fax: 970.245.7737
www.geostabilization.com



C:\Users\jacob@gsi.com\Desktop\Projects\210487CA01\Las Brisas Condominiums\Basis\Drawings\General Notes\GSI-C-03.dwg - 9/27/2021 4:11 PM

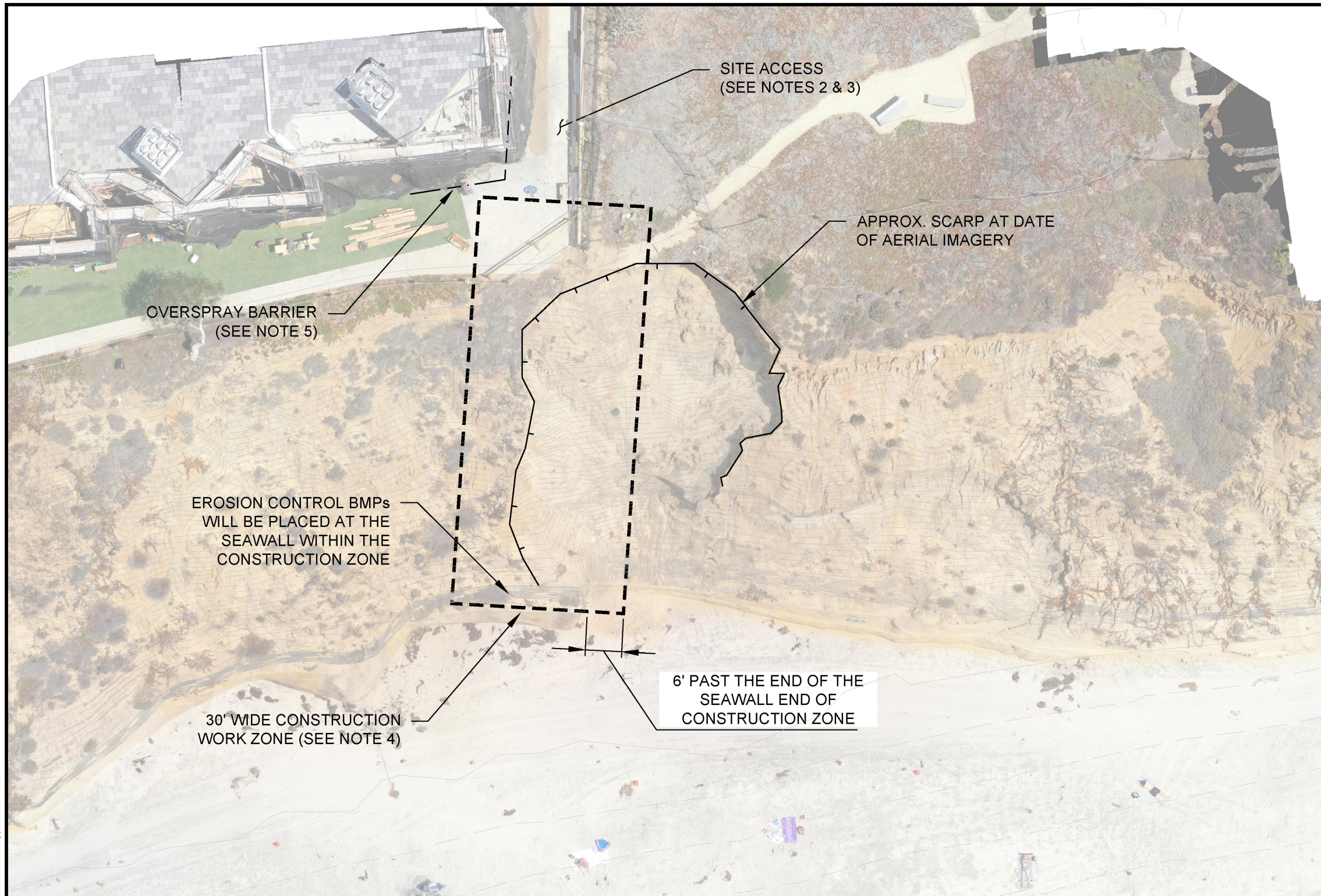

NOTES:

1. BACKGROUND IMAGE OBTAINED FROM GSI DRONE FLIGHT AERIAL IMAGERY, FLOWN ON 8/25/21. EXISTING TOPOGRAPHY DATA OBTAINED FROM PASCO LARET SUITER & ASSOCIATES, PLSA JOB #2710.
2. CONSTRUCTION ACCESS CORRIDOR IS LOCATED ALONG THE SOUTH SIDE OF THE LAS BRISAS CONDOMINIUMS. CARE SHOULD BE TAKEN TO LIMIT IMPACT TO THE CONDOMINIUM AND PUBLIC ACCESS IN THE AREA.
3. CONSTRUCTION MATERIALS AND EQUIPMENT SHALL BE MOVED FROM THE STAGING SITE AND RESTORE THE STAGING TO ITS PRIOR-TO-CONSTRUCTION CONDITION WITHIN 72 HRS FOLLOWING COMPLETION OF THE PROJECT.
4. GSI TO PROVIDE CONSTRUCTION BARRIER DURING WORKING HOURS TO SEPARATE WORK ZONE FROM OPEN PUBLIC BEACH. LATERAL PUBLIC ACCESS SHALL BE PROVIDED PAST THE SITE AT ALL TIMES.
5. GSI WILL USE A PLASTIC OR SIMILAR BARRIER TO PROTECT THE BUILDING FROM SHOTCRETE OVERSPRAY. ANTICIPATE DRAPING FROM THE 3RD DECK TO GROUND LEVEL.

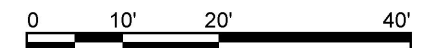
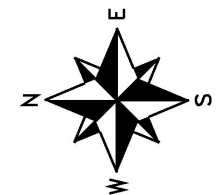

SHEET REVISIONS

DATE	DESCRIPTION	NO
09/01/21	ISSUED FOR REVIEW	IFR
09/27/21	ISSUED FOR PERMIT	IFP

PROJECT NAME:
LAS BRISAS CONDOMINIUMS

SHEET TITLE:
EXISTING SITE & ACCESS PLAN

THIS DRAWING IS FURNISHED SOLELY FOR THE USE OF OR IN CONNECTION WITH THIS PROJECT AND THE PROPRIETARY INFORMATION SHOWN HEREON IS NOT TO BE TRANSMITTED TO ANY OTHER ORGANIZATION WITHOUT SPECIFIC AUTHORIZATION BY GEOSTABILIZATION INTERNATIONAL (GSI). THE DESIGN IS ONLY VALID IF CONSTRUCTED AND SUPERVISED BY GSI OR ITS AUTHORIZED SUBCONTRACTOR.

DRAWN BY: MAC	CHECKED BY: JDR	DATE: 09/27/21	PROJECT NUMBER: 210487CA01	SHEET C-04
-------------------------	---------------------------	--------------------------	--------------------------------------	----------------------



Phone: 855.579.0536 | Fax: 970.245.7737
www.geostabilization.com



© 2021 Geostabilization International. All rights reserved. This drawing is the property of Geostabilization International and is not to be reproduced, stored in a retrieval system, or transmitted in any form or by any means, electronic, mechanical, photocopying, recording, or by any information storage and retrieval system, without the prior written permission of Geostabilization International.

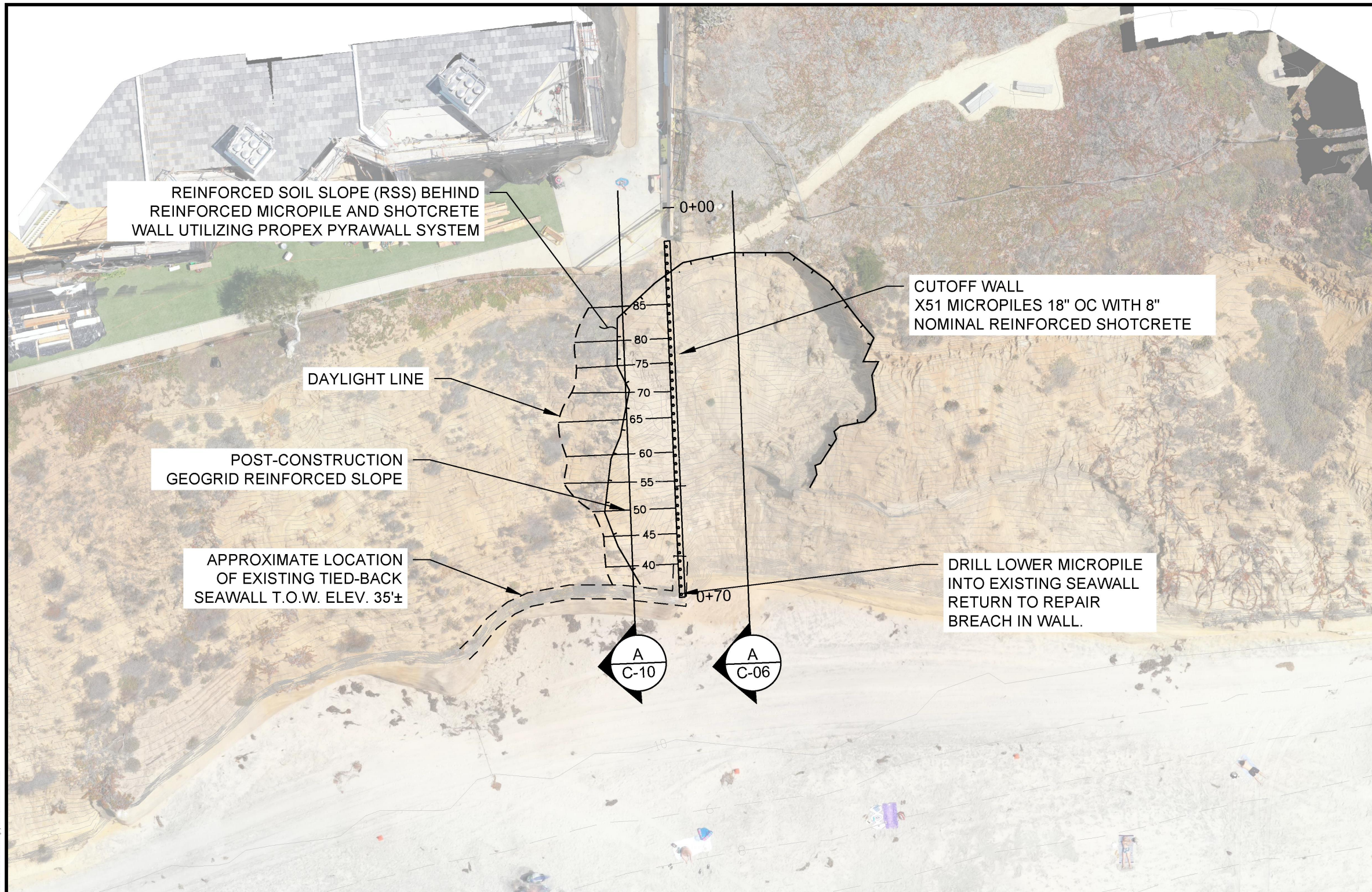

- NOTES:
- BACKGROUND IMAGE OBTAINED FROM GSI DRONE FLIGHT ON 8/25/21. EXISTING TOPOGRAPHY DATA OBTAINED FROM PASCO LARET SUITER & ASSOCIATES, PLSA JOB #2710.

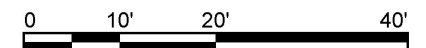
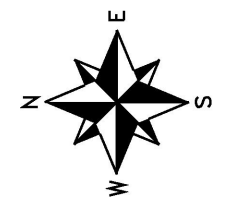

SHEET REVISIONS

DATE	DESCRIPTION	NO
09/01/21	ISSUED FOR REVIEW	IFR
09/27/21	ISSUED FOR PERMIT	IFP

PROJECT NAME:
LAS BRISAS CONDOMINIUMS

SHEET TITLE:
PROJECT SITE PLAN

THIS DRAWING IS FURNISHED SOLELY FOR THE USE OF OR IN CONNECTION WITH THIS PROJECT AND THE PROPRIETARY INFORMATION SHOWN HEREON IS NOT TO BE TRANSMITTED TO ANY OTHER ORGANIZATION WITHOUT SPECIFIC AUTHORIZATION BY GEOSTABILIZATION INTERNATIONAL (GSI). THE DESIGN IS ONLY VALID IF CONSTRUCTED AND SUPERVISED BY GSI OR ITS AUTHORIZED SUBCONTRACTOR.

DRAWN BY: MAC	CHECKED BY: JDR	DATE: 09/27/21	PROJECT NUMBER: 210487CA01	SHEET C-05
------------------	--------------------	-------------------	-------------------------------	---------------



Phone: 855.579.0536 | Fax: 970.245.7737
www.geostabilization.com



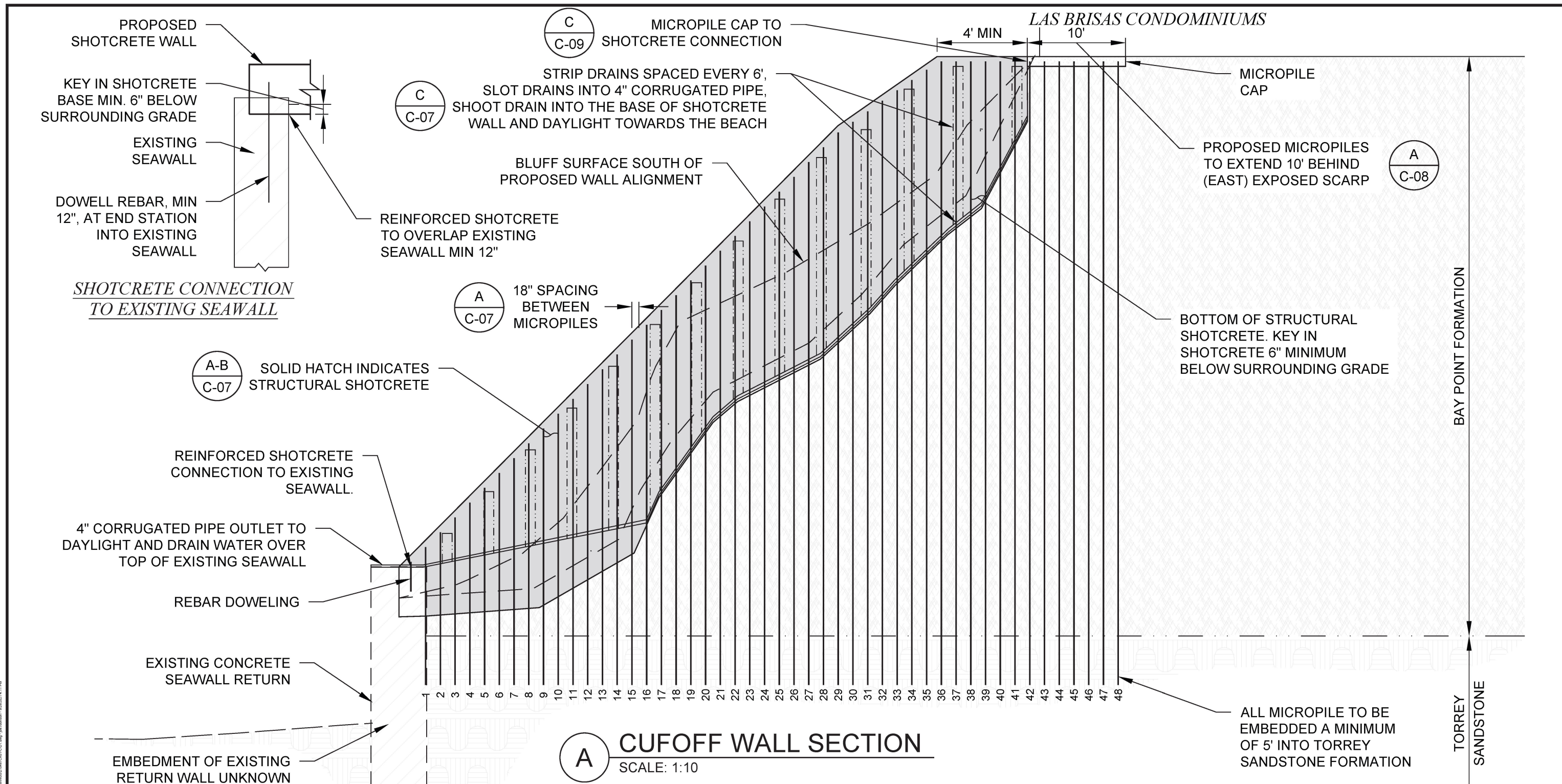

A CUTOFF WALL SECTION
SCALE: 1:10

SHEET REVISIONS		
DATE	DESCRIPTION	NO
09/01/21	ISSUED FOR REVIEW	IFR
09/27/21	ISSUED FOR PERMIT	IFP

PROJECT NAME:
LAS BRISAS CONDOMINIUMS

SHEET TITLE:
SECTION VIEW - CUTOFF WALL

DRAWN BY: MAC	CHECKED BY: JDR	DATE: 09/27/21	PROJECT NUMBER: 210487CA01	SHEET C-06
------------------	--------------------	-------------------	-------------------------------	---------------

Phone: 855.579.0536 | Fax: 970.245.7737
www.geostabilization.com



C:\Users\mlozano\OneDrive\Desktop\Projects\210487CA01 - Las Brisas Condominiums\Drawings\210487CA01-C-06.dwg, 9/20/21 4:11 PM

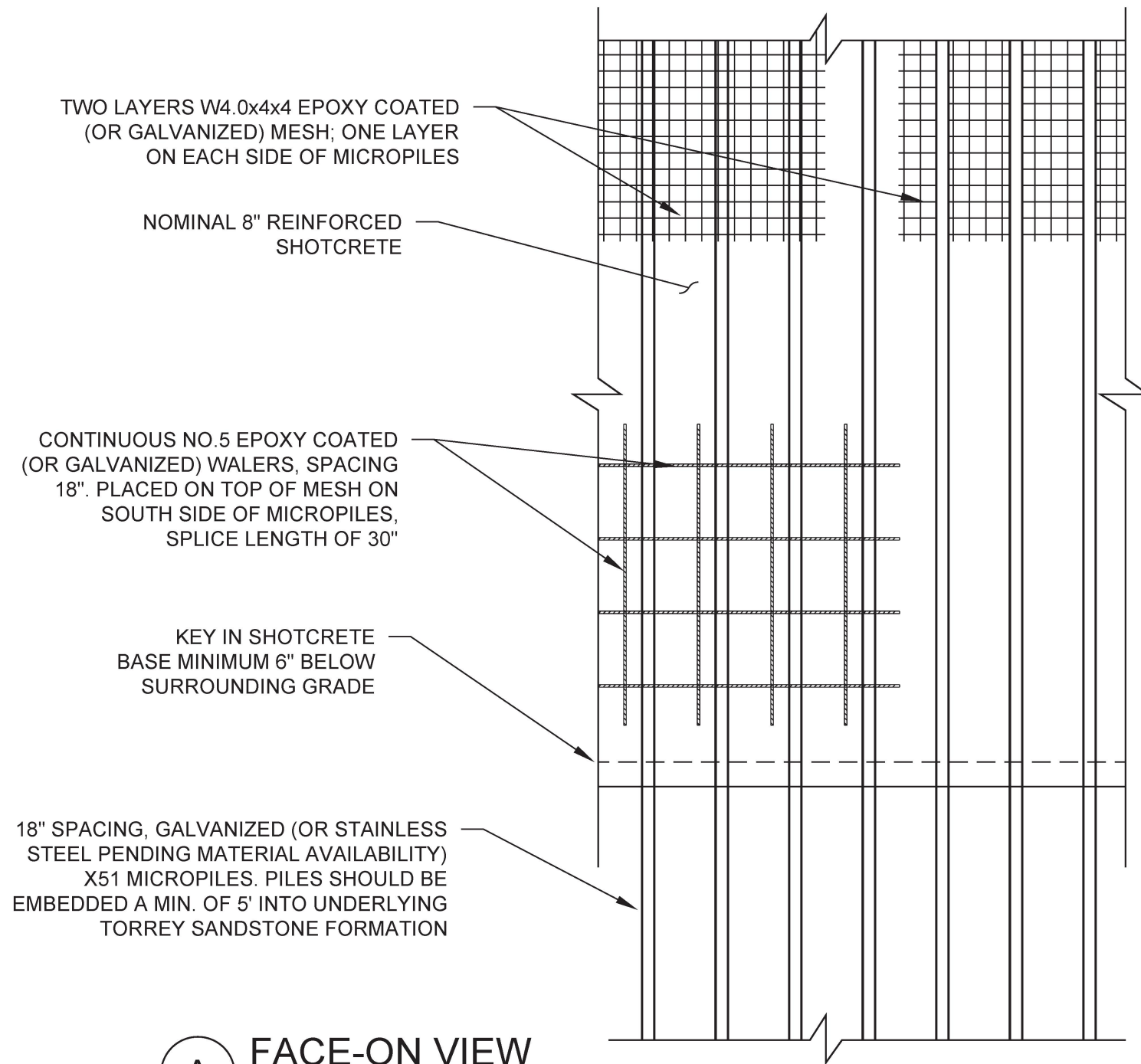

A FACE-ON VIEW
N.T.S.

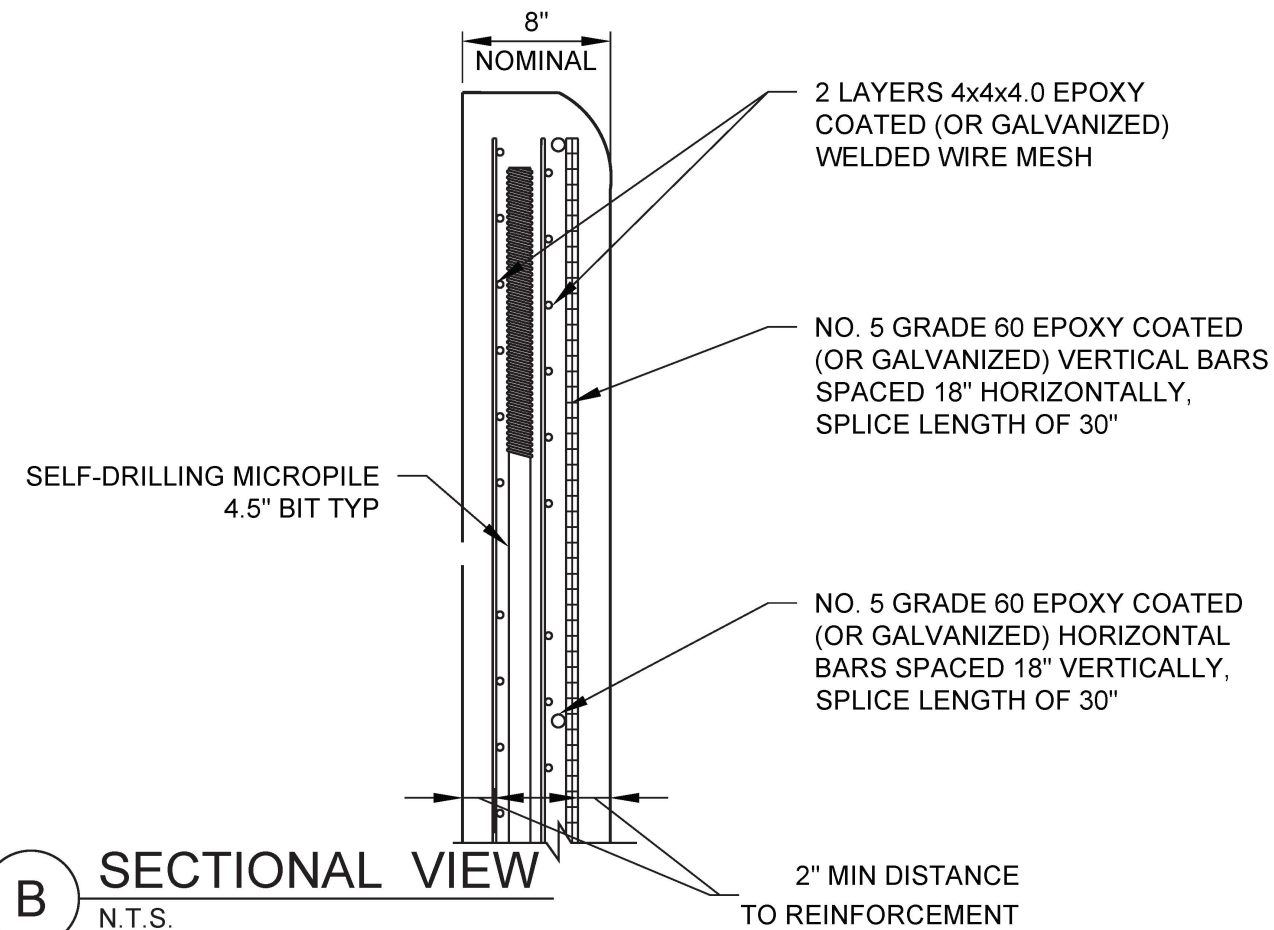

B SECTIONAL VIEW
N.T.S.

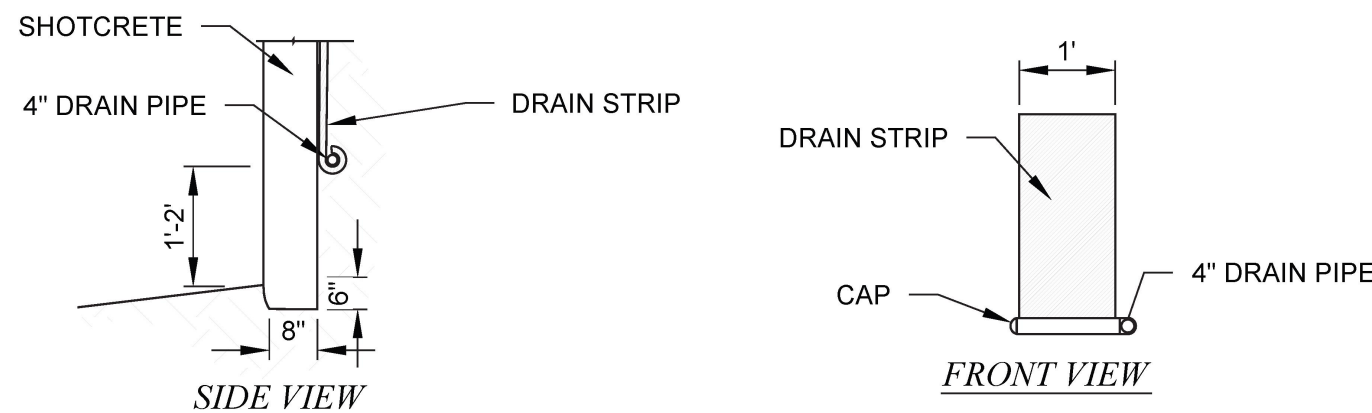

C DRAIN CONNECTION DETAIL
N.T.S.

SHEET REVISIONS

DATE	DESCRIPTION	NO
09/01/21	ISSUED FOR REVIEW	IFR
09/27/21	ISSUED FOR PERMIT	IFP

PROJECT NAME:
LAS BRISAS CONDOMINIUMS

SHEET TITLE:
CUTOFF WALL DETAILS

THIS DRAWING IS FURNISHED SOLELY FOR THE USE OF OR IN CONNECTION WITH THIS PROJECT AND THE PROPRIETARY INFORMATION SHOWN HEREON IS NOT TO BE TRANSMITTED TO ANY OTHER ORGANIZATION WITHOUT SPECIFIC AUTHORIZATION BY GEOSTABILIZATION INTERNATIONAL (GSI). THE DESIGN IS ONLY VALID IF CONSTRUCTED AND SUPERVISED BY GSI OR ITS AUTHORIZED SUBCONTRACTOR.

DRAWN BY: MAC	CHECKED BY: JDR	DATE: 09/27/21	PROJECT NUMBER: 210487CA01	SHEET C-07
------------------	--------------------	-------------------	-------------------------------	---------------



Phone: 855.579.0536 | Fax: 970.245.7737
www.geostabilization.com



C:\Users\jacob@gsi.com\Desktop\Projects\210487CA01 - Las Brisas Condominiums\Drawings\210487CA01-C-07.dwg, 9/20/21 4:11 PM

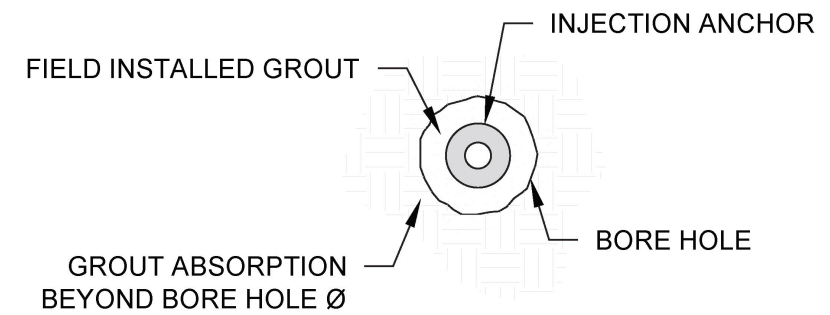
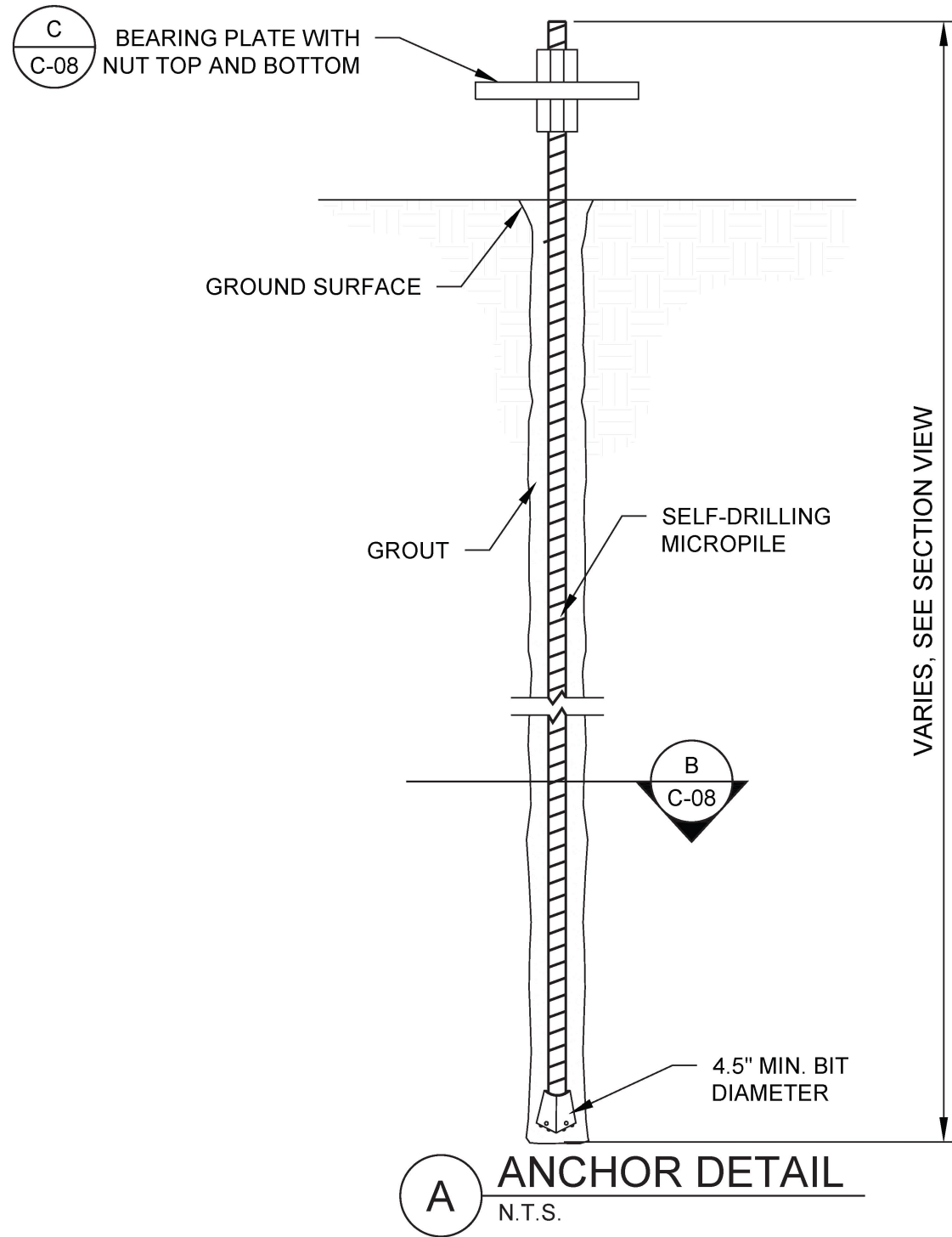

B MICROPILE SECTION
N.T.S.

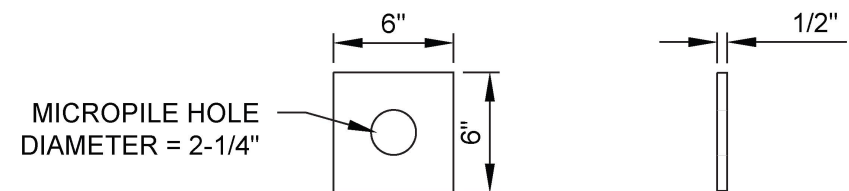

C MICROPILE BEARING PLATE
N.T.S.

SHEET REVISIONS

DATE	DESCRIPTION	NO
09/01/21	ISSUED FOR REVIEW	IFR
09/27/21	ISSUED FOR PERMIT	IFP

PROJECT NAME:
LAS BRISAS CONDOMINIUMS

SHEET TITLE:
MICROPILE ANCHOR DETAILS

THIS DRAWING IS FURNISHED SOLELY FOR THE USE OF OR IN CONNECTION WITH THIS PROJECT AND THE PROPRIETARY INFORMATION SHOWN HEREON IS NOT TO BE TRANSMITTED TO ANY OTHER ORGANIZATION WITHOUT SPECIFIC AUTHORIZATION BY GEOSTABILIZATION INTERNATIONAL (GSI). THE DESIGN IS ONLY VALID IF CONSTRUCTED AND SUPERVISED BY GSI OR ITS AUTHORIZED SUBCONTRACTOR.

DRAWN BY: MAC	CHECKED BY: JDR	DATE: 09/27/21	PROJECT NUMBER: 210487CA01	SHEET C-08
------------------	--------------------	-------------------	-------------------------------	---------------



Phone: 855.579.0536 | Fax: 970.245.7737
www.geostabilization.com



C:\Users\jacob\OneDrive\Documents\Projects\210487CA01 - Las Brisas Condominiums\Bentley\210487CA01.dwg - 9/20/21 4:11 PM

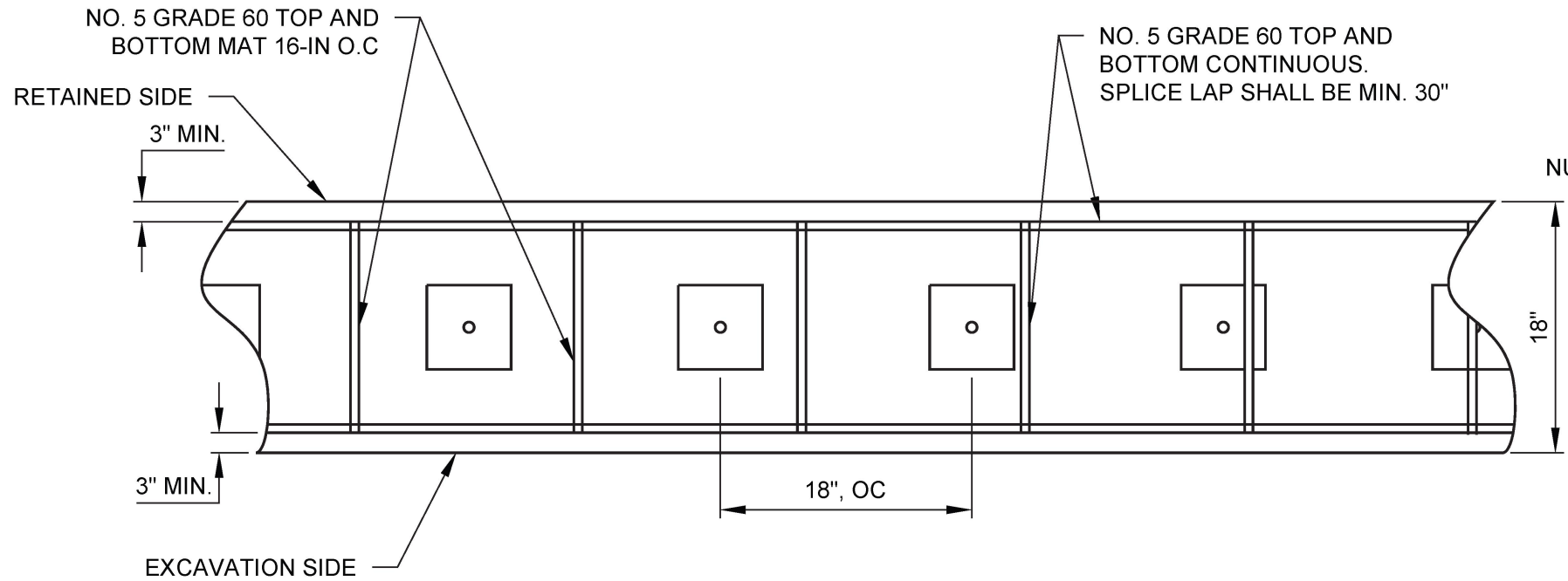

A MICROPILES - TOP VIEW
N.T.S.

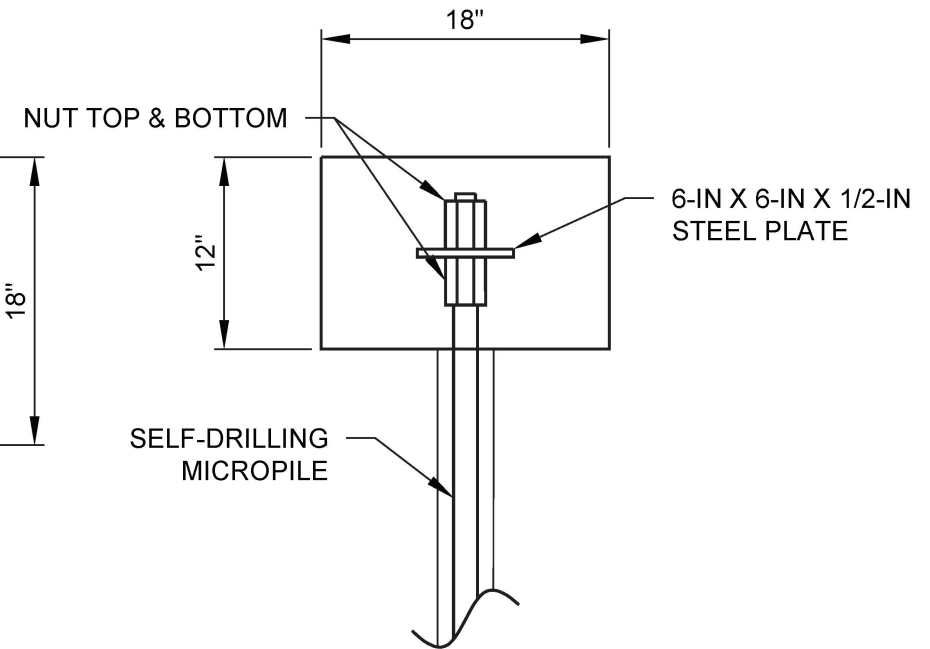

B MICROPILES - END VIEW
N.T.S.

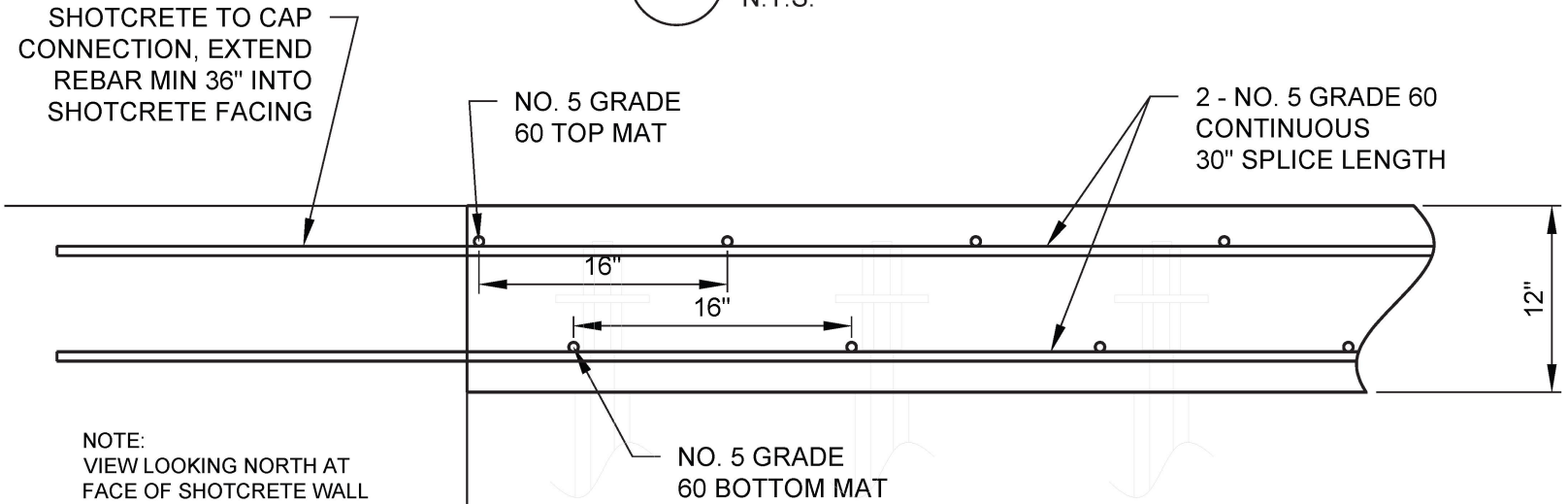

C MICROPILES - SIDE VIEW
N.T.S.

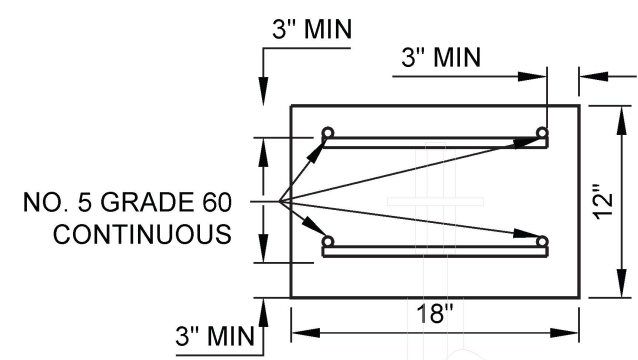

D REINFORCEMENT - END VIEW
N.T.S.

SHEET REVISIONS

DATE	DESCRIPTION	NO
09/01/21	ISSUED FOR REVIEW	IFR
09/27/21	ISSUED FOR PERMIT	IFP

PROJECT NAME:
LAS BRISAS CONDOMINIUMS

SHEET TITLE:
MICROPILE CAP DETAILS

DRAWN BY: MAC	CHECKED BY: JDR	DATE: 09/27/21	PROJECT NUMBER: 210487CA01	SHEET C-09
------------------	--------------------	-------------------	-------------------------------	---------------



Phone: 855.579.0536 | Fax: 970.245.7737
www.geostabilization.com



C:\Users\jacob@gsi.com\Desktop\Projects\210487CA01 - Las Brisas Condominiums\Rev\210487CA01-C09.dwg 9/27/21 4:11 PM

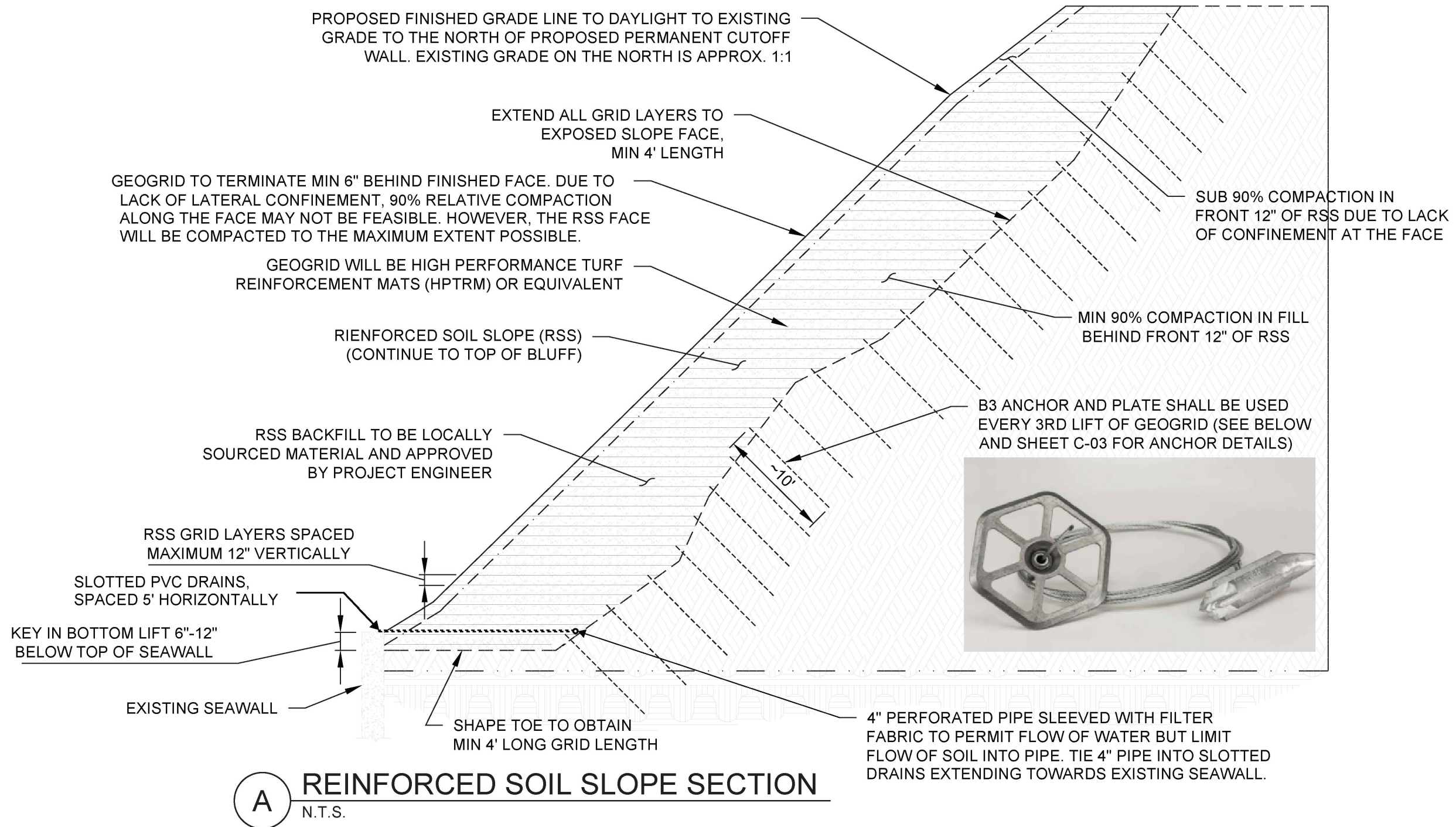

SHEET REVISIONS

DATE	DESCRIPTION	NO
09/01/21	ISSUED FOR REVIEW	IFR
09/27/21	ISSUED FOR PERMIT	IFP

PROJECT NAME:
LAS BRISAS CONDOMINIUMS

SHEET TITLE:
SECTION VIEW - RSS SYSTEM

THIS DRAWING IS FURNISHED SOLELY FOR THE USE OF OR IN CONNECTION WITH THIS PROJECT AND THE PROPRIETARY INFORMATION SHOWN HEREON IS NOT TO BE TRANSMITTED TO ANY OTHER ORGANIZATION WITHOUT SPECIFIC AUTHORIZATION BY GEOSTABILIZATION INTERNATIONAL (GSI). THE DESIGN IS ONLY VALID IF CONSTRUCTED AND SUPERVISED BY GSI OR ITS AUTHORIZED SUBCONTRACTOR.

DRAWN BY: MAC	CHECKED BY: JDR	DATE: 09/27/21	PROJECT NUMBER: 210487CA01	SHEET C-10
------------------	--------------------	-------------------	-------------------------------	---------------



Phone: 855.579.0536 | Fax: 970.245.7737
www.geostabilization.com



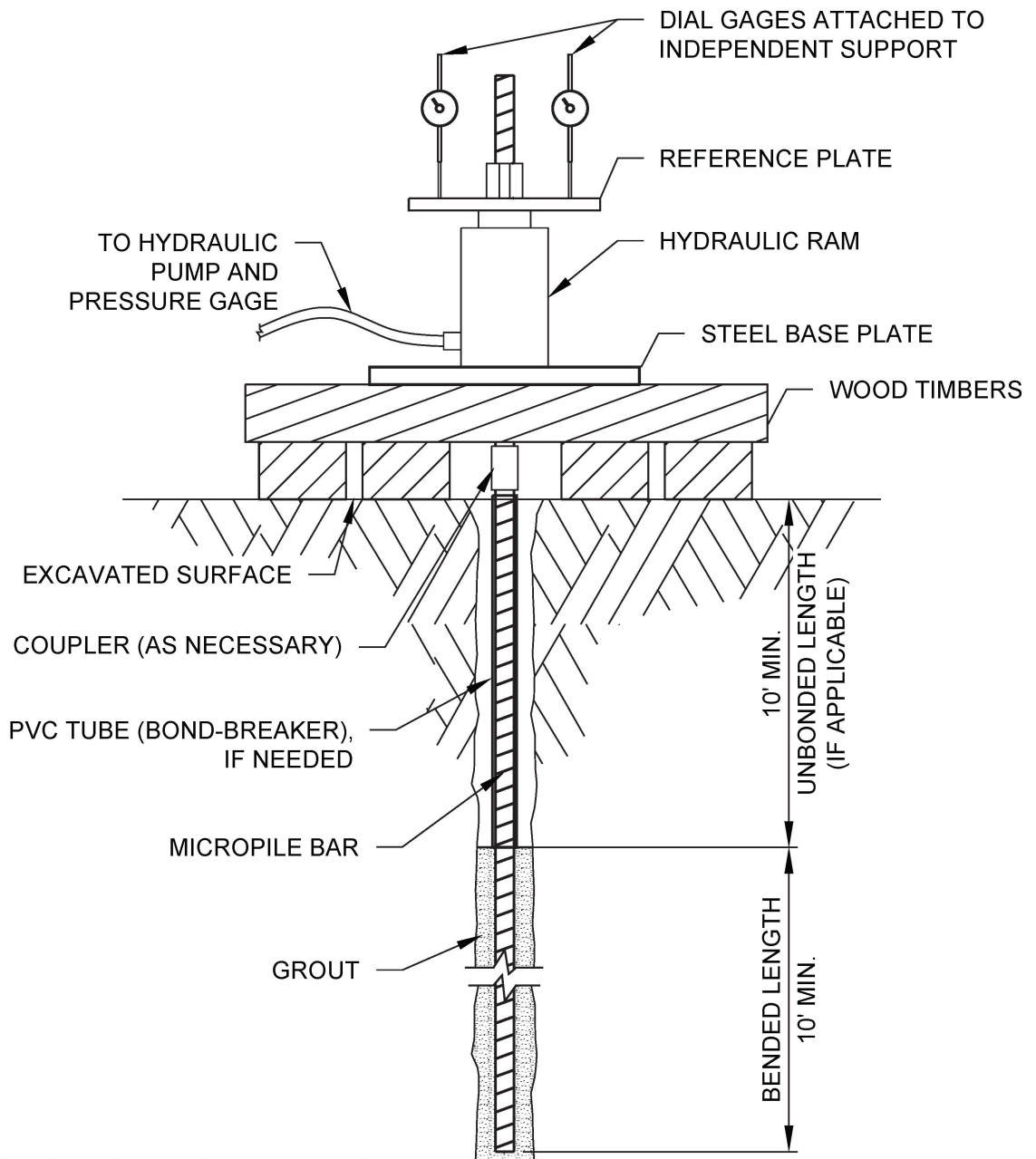

PROOF MICROPILE TESTING PROCEDURE AND EQUIPMENT:

- THE REACTION FRAME WILL BE SUFFICIENTLY RIGID AND OF ADEQUATE DIMENSIONS SO THAT EXCESSIVE DEFORMATION OF THE TESTING EQUIPMENT DOES NOT OCCUR. THE REACTION FRAME WILL BE SUPPORTED INDEPENDENTLY OF THE MICROPILE BAR. THE CONFIGURATION OF THE TESTING APPARATUS WILL BE POSITIONED TO REDUCE THE POTENTIAL OF THE NEED FOR THE RAM, BEARING PLATES, AND STRESSING ANCHORAGE TO BE REPOSITIONED DURING A TEST.
- THE LOAD WILL BE APPLIED WITH A HYDRAULIC RAM AND MEASURED WITH A PRESSURE GAUGE. THE PRESSURE GAUGE WILL BE GRADUATED IN 100 PSI INCREMENTS OR LESS. THE RAM, PRESSURE GAUGES, AND PUMPS WILL HAVE BEEN CALIBRATED WITH EACH OTHER WITHIN THE LAST YEAR BY AN INDEPENDENT AASHTO ACCREDITED LABORATORY OR BY A DEPARTMENT LABORATORY.
- MOVEMENT OF THE BAR HEAD SHALL BE MEASURED WITH AT LEAST ONE DIAL GAUGE CAPABLE OF MEASURING TO THE NEAREST 0.001 INCH. THE GAUGE WILL BE VISUALLY ALIGNED TO BE PARALLEL WITH THE AXIS OF THE BAR AND SHALL BE SUPPORTED INDEPENDENTLY OF THE RAM AND REACTION FRAME. GENERALLY TWO DIAL GAUGES ARE UTILIZED, IF POSSIBLE.
- TESTING SHALL BE PERFORMED BY INCREMENTALLY LOADING THE BAR PER TO THE LOADING SCHEDULE PROVIDED BELOW. THE BAR HEAD MOVEMENTS SHALL BE RECORDED AT EACH LOAD INCREMENT WITH THE DIAL GAUGE(S).

DESIGN LOAD (DL):

- LOADING ON THE BAR SHALL BE APPLIED BASED ON THE DESIGN LOAD AS DETERMINED BY FHWA PUBLICATION NHI 05-039, MICROPILE DESIGN AND CONSTRUCTION.
- DESIGN BOND STRENGTH FOR THIS PROJECT IS 615 LB/FT OF BOND.
- THE DESIGN LOAD (DL) IS DETERMINED BY MULTIPLYING THE DESIGN BOND VALUES BY THE BOND LENGTH OF MICROPILE. THE BOND LENGTH FOR TESTING SHOULD BE AT LEAST 10-FT.

TESTING OF MICROPILES:

- PROOF TESTING WILL BE PERFORMED ON 5% OF PRODUCTION MICROPILES. LOADING WILL BE APPLIED IN TENSION.
- A MINIMUM 48-HOUR NOTICE WILL BE PROVIDED TO THE CITY'S REPRESENTATIVES PROVIDED THEY WISH TO OBSERVE MICROPILE TESTING AT THE SITE.
- TESTS SHALL OCCUR IN LOCATIONS DETERMINED BY GSI FIELD PERSONNEL ON SITE.
- THE ALIGNMENT LOAD (AL) SHALL BE APPLIED TO ALIGN THE TESTING APPARATUS. DIAL GAUGES FOR MEASURING THE MOVEMENT OF THE TEST NAIL SHALL BE SET TO "ZERO" AFTER THE ALIGNMENT LOAD HAS BEEN APPLIED.

LOADING SCHEDULE FOR PROOF TEST

LOADING	LOAD	HOLD TIME
AL	0.025 DL MAX	2.5 MINUTES
LOAD CYCLE	0.30 DL	2.5 MINUTES
"	0.45 DL	2.5 MINUTES
"	0.60 DL	2.5 MINUTES
"	0.75 DL	2.5 MINUTES
"	0.90 DL	2.5 MINUTES
"	1.00 DL	2.5 MINUTES
"	1.15 DL	2.5 MINUTES
		HOLD 1.30 DL ABOVE FOR 10 MINUTES WHILE RECORDING MOVEMENT AT 1, 2, 3, 4, 5, 6, AND 10 MINUTES. IF TOTAL MOVEMENT MEASURED DURING LOAD EXCEEDS 0.04 INCHES BETWEEN THE 1 AND 10 MINUTE AVERAGE READINGS THEN THE LOAD SHOULD BE HELD ON MICROPILE FOR AN ADDITIONAL 50 MINUTES, RECORDING MOVEMENT AT 20, 30, 40, 50, AND 60 MINUTES.
LOAD CYCLE	1.45 DL	2.5 MINUTES
"	1.60 DL	2.5 MINUTE
UNLOAD CYCLE	1.30 DL	4 MINUTES
"	1.00 DL	4 MINUTES
"	0.75 DL	4 MINUTES
"	0.50 DL	4 MINUTES
"	0.25 DL	4 MINUTES
AL	0.025 DL MAX	4 MINUTES

MICROPILE TEST ACCEPTANCE CRITERIA:

- THE SLOPE OF THE LOAD VERSUS DISPLACEMENT CURVE IS LESS THAN OR EQUAL TO 0.025 IN/KIP AT 2.00 DL.
- THE TOTAL MOVEMENT AT 1.3 DL (CREEP) DOES NOT EXCEED 0.04 INCHES BETWEEN 1 AND 10 MINUTE READINGS, OR THE TOTAL MOVEMENT DOES NOT EXCEED 0.08 INCHES BETWEEN 6 AND 60 MINUTE READINGS.

C:\Users\jacob@gsi.com\Desktop\Projects\210487CA01 - Las Brisas Condominiums\Drawings\210487CA01-C-08.dwg, 09/27/21 4:11 PM

SHEET REVISIONS		
DATE	DESCRIPTION	NO
09/01/21	ISSUED FOR REVIEW	IFR
09/27/21	ISSUED FOR PERMIT	IFP

PROJECT NAME: LAS BRISAS CONDOMINIUMS				
SHEET TITLE: MICROPILE TESTING DETAILS				
DRAWN BY: MAC	CHECKED BY: JDR	DATE: 09/27/21	PROJECT NUMBER: 210487CA01	SHEET C-08

Phone: 855.579.0536 | Fax: 970.245.7737
www.geostabilization.com



THIS DRAWING IS FURNISHED SOLELY FOR THE USE OF OR IN CONNECTION WITH THIS PROJECT AND THE PROPRIETARY INFORMATION SHOWN HEREON IS NOT TO BE TRANSMITTED TO ANY OTHER ORGANIZATION WITHOUT SPECIFIC AUTHORIZATION BY GEOSTABILIZATION INTERNATIONAL (GSI). THE DESIGN IS ONLY VALID IF CONSTRUCTED AND SUPERVISED BY GSI OR ITS AUTHORIZED SUBCONTRACTOR.

**GEOTECHNICAL UPDATE AND RESPONSE TO THIRD-PARTY
GEOTECHNICAL REVIEW, LAS BRISAS CONDOMINIUMS
BLUFF STABILIZATION, 135 SOUTH SIERRA AVENUE
SOLANA BEACH, SAN DIEGO COUNTY, CALIFORNIA 92075
CUP20-004**

GeoSoils, Inc. FOR

**MS. RENEE RESLER, PRESIDENT
LAS BRISAS HOMEOWNER'S ASSOCIATION
C/O THE TRETTIN COMPANY
1195 LA MOREE ROAD, #18
SAN MARCOS, CALIFORNIA 92078**

W.O. 8157-A-SC OCTOBER 22, 2021



Geotechnical • Geologic • Coastal • Environmental

5741 Palmer Way • Carlsbad, California 92010 • (760) 438-3155 • FAX (760) 931-0915 • www.geosoilsinc.com

October 22, 2021

W.O. 8157-A-SC

Ms. Renee Resler, President
Las Brisas Homeowner's Association
c/o **The Trettin Company**
1195 La Moree Road, #18
San Marcos, California 92078

Attention: Mr. Bob Trettin

Subject: Geotechnical Update and Response to Third-Party Geotechnical Review,
Las Brisas Condominiums Bluff Stabilization, 135 South Sierra Avenue,
Solana Beach, San Diego County, California 92075, CUP20-004

Dear Mr. Trettin:

In accordance with your request and authorization, GeoSoils, Inc. (GSI) has prepared this geotechnical update and response to the review comments provided by the City of Solana Beach's Third-Party Geotechnical Consultant, relative to the proposed stabilization of the coastal bluff at the subject site (Construction Testing & Engineering, Inc. [CTE], 2021 [see Appendix A]). This report also provides supplements to the global stability analyses previously performed by Terracosta Consulting Group (TCG) that accompanied their letter dated September 25, 2020 (TCG, 2020b). The scope of services performed for this study included reviews of previous site-specific geotechnical reports for the subject property (Anthony-Taylor Consultants [ATC], 2004b; TCG, 2021), geologic mapping, geotechnical engineering analysis, including slope stability, and the preparation of this report.

SITE DESCRIPTION AND PROPOSED DEVELOPMENT

Site Description

The Las Brisas Condominium property is located at 135 South Sierra Avenue in the City of Solana Beach, San Diego County, California 92075 (see Figure 1, Site Location Map). The geographic coordinates of the approximate centroid of the site are 32.9906° North, -117.2734° West. The property includes an approximately 74-foot high coastal bluff slope, ascending from the Pacific Ocean shoreline. The property is bounded by South Sierra Avenue to the east, by the Pacific Ocean shoreline to the west, by Fletcher Cove Beach Park and the City of Solana Beach Marine Safety Department to the north, and by United States Postal Service property and existing multi-family residential development (Surfsong Condominiums) to the remaining quadrant.

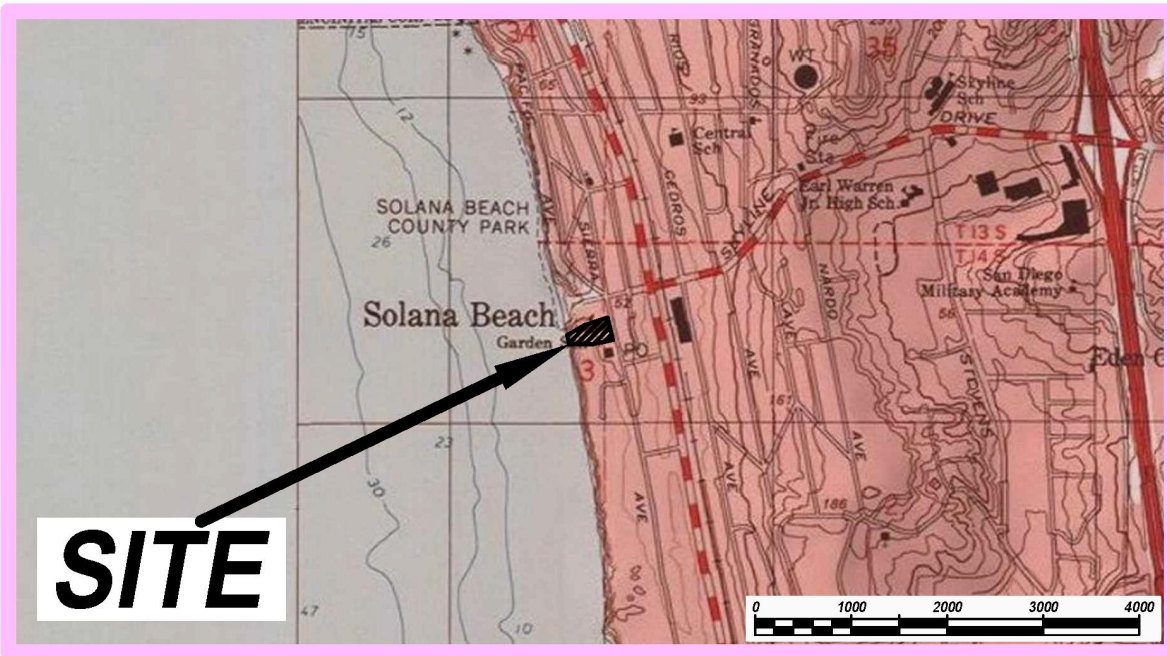

Base Map: TOPO!® ©2003 National Geographic, U.S.G.S. Del Mar Quadrangle, California -- San Diego Co., 7.5 Minute, dated 1994, current, 1994.

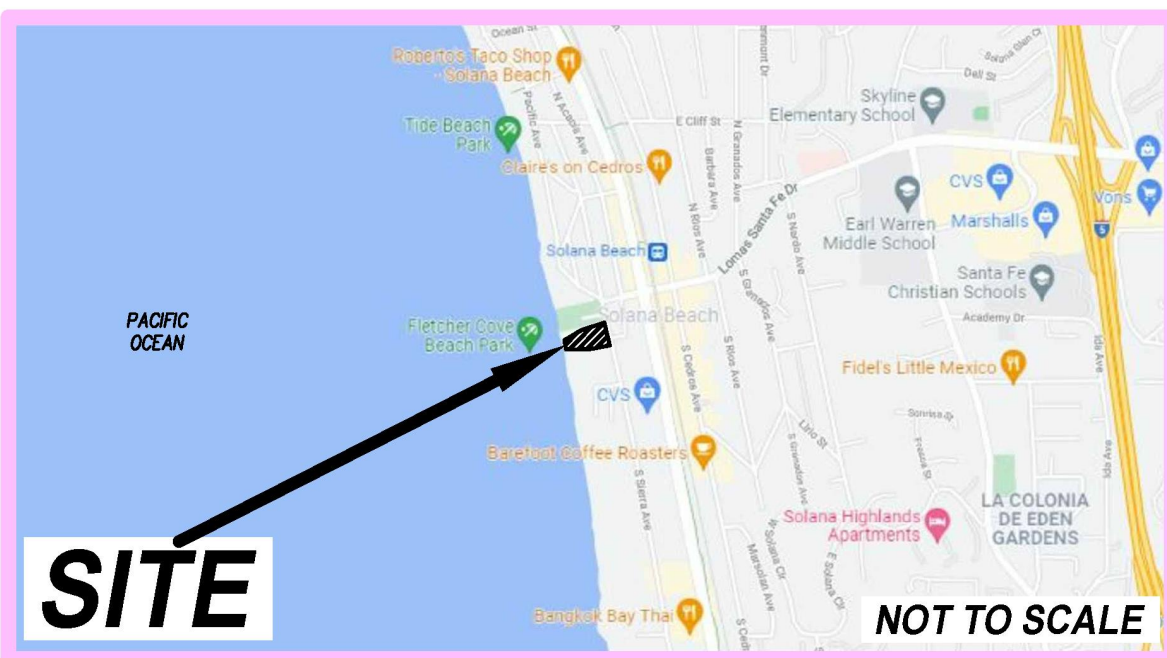

Base Map: Google Maps, Copyright 2021 Google, Map Data Copyright 2021 Google

This map is copyrighted by Google 2021. It is unlawful to copy or reproduce all or any part thereof, whether for personal use or resale, without permission. All rights reserved.

	<p>W.O. 8157-A-SC</p>
<p>SITE LOCATION MAP</p>	



Figure 1

Topographically, the subject site occurs upon a relatively flat-lying to moderately sloping anthropogenically modified coastal terrace and a steeply sloping coastal bluff. The coastal bluff edge divides the coastal terrace from the coastal bluff.

According to the topographic survey prepared by Pasco, Laret, Suiter, and Associates ([PLS&A], 2020), the coastal terrace generally slopes to the east and north at gradients on the order of 1.6:1 (horizontal:vertical [h:v]) or flatter. However, localized anthropogenic alterations have created small slopes with gradients as steep as approximately ½:1 (h:v), near the eastern property margin. PLS&A (2020) indicates that slope gradients are as steep as 0.7:1 (h:v) along the upper portion of the coastal bluff and near-vertical along its exposed toe. However, the failure head scarp, created by the recent bluff failure, has resulted in localized near-vertical slope gradients in the upper bluff.

PLS&A (2020) shows that site elevations vary between approximately 11 and 90 feet (datum = North American Vertical Datum [NAVD88]). Thus, the overall relief across the Las Brisas Condominiums property is roughly 79 feet.

In general, site drainage is primarily accommodated by sheet-flow runoff that follows the site topography. However, a private storm drain system assists in the collection and conveyance of surface runoff toward South Sierra Avenue, within the developed portion of the subject property.

Onsite improvements consist of two (2), four-story and one (1) three-story condominium buildings, a one-story clubhouse, a swimming pool, a tennis court, and associated underground utilities, retaining walls, and vehicular and pedestrian pavements. Existing landscaping generally consists of sparse trees, shrubbery, flowers, and artificial turf. At their closest point, the horizontal separation between the seaward foundation of the westernmost condominium building (referred to hereinafter as Building 3) and the coastal bluff edge is approximately 27 feet.

The basal portion of the coastal bluff at the subject site is currently afforded protection from marine erosion by an existing seawall consisting of an approximately 120-foot long hand-sculpted and colored shotcrete wall restrained by three (3) rows of 75-foot long tiebacks (Soil Engineering Construction, Inc., personal communication). The top of the shotcrete wall extends to elevation 35 mean sea level (MSL) or approximately 37 feet NAVD88. Geogrid-reinforced fill was placed above the top of the seawall to approximate elevation 45 feet MSL or roughly 47 feet NAVD88 to create a relatively uninterrupted transition between the top of the seawall and the upper bluff slope.

Based on our review of an application letter for a Conditional Use Permit (CUP) amendment, prepared by The Trettin Company ([TC], 2020) it is our understanding that a significant failure of the coastal bluff occurred immediately south of the existing seawall in August 2019. According to TC (2020), the failure has undergone progressive headward retreat since that time, and has impacted a recorded easement for public

agency vehicles, including emergency vehicles. In addition, it necessitated a City of Solana Beach-mandated closure of public pedestrian access from nearby Fletcher Cove, across the Las Brisas property, into a public open space area on the adjacent Surfsong Condominium property to the south. This bluff failure is the focus of this geotechnical update evaluation.

GEOTECHNICAL BACKGROUND

In 2004, ATC completed a geotechnical evaluation of the subject site to study the coastal bluff conditions present at that time and to assess the potential for bluff instability, resulting from marine and subaerial erosional processes. ATC's study included: reviews of available proprietary and nonproprietary photographs, maps, reports and other pertinent documents; a review of the subsurface findings and laboratory test data obtained from their previous, onsite study; reconnaissance observations, mapping, and photographic documentation of the site and coastal bluff; topographic surveying of the lower and middle coastal bluff areas; the preparation of representative geologic cross sections; engineering and geologic analyses of the collected data, including quantitative slope stability analyses; and the preparation of a summary report presenting their engineering geological, and geotechnical findings related to the existing bluff conditions, and providing recommendations for mitigation of progressive coastal bluff retreat occurring at the time of their evaluation (ATC, 2004b).

The earth materials encountered during ATC's previous (November 2003) field exploration and their more recent site reconnaissance, performed in preparation of ATC (2004b), included: transient, Quaternary-age beach deposits along the shoreline; a localized mantle of artificial fill with a maximum estimated thickness of approximately 12 feet within the developed portion of the subject property; Quaternary-age Bay Point Formation (now referred to as Quaternary-age old paralic deposits on recent regional geologic maps [Kennedy and Tan, 2008]) in the upper portion of the coastal bluff, and in the near-surface within the developed portion of the subject property; and Tertiary-age sedimentary bedrock, belonging to the Torrey Sandstone, exposed in the basal portion of the coastal bluff (i.e., sea cliff) and unconformably underlying the Bay Point Formation and beach deposits. ATC also encountered offsite landslide debris within the lower portion of the north-facing bluff descending toward nearby Fletcher Cove. Given their location relative to the bluff failure under the purview of this report, the landslide deposits described in ATC (2004b) are not considered relevant to this update; and therefore, not further discussed herein.

ATC (2004b) stated that the artificial fill materials they encountered were reportedly placed during original site development. Their review of the original grading plans for the Las Brisas Condominiums complex indicated that approximately 7 to 10 feet of planned fill was necessary to create the design grades near the northeastern portion of the property, and original planned fill thicknesses varying between approximately 6 and 10 feet

were required to attain the design grades in the southeastern and central portions of the subject address. ATC reported that no significant fills occurred within the vicinity of the coastal bluff, and no fill was placed beneath Building 3. ATC concluded that the overall thickness of fill materials at the subject site ranged between approximately 2 and 12 feet, with the deepest fill occurring as backfill for the retaining walls associated with the subterranean parking levels for the two (2) eastern condominium buildings.

According to ATC (2004b), the beach deposits generally consisted of loose, unconsolidated, sand with gravels and cobbles. At the time of their study, ATC estimated the thickness of the beach deposits varied between approximately 3 and 7 feet, depending on seasonal, tidal, and storm conditions.

ATC (2004b) reported that the Bay Point Formation at the subject property consisted of three (3) distinct parts or subunits. They described the upper part as dense, reddish brown, slightly clayey sand with an approximate thickness of 6 to 10 feet; the middle part as approximately 39 to 44 feet of moderately loose to dense, light tan to gray sand; and the lower part as a roughly 3- to 5-foot thick, fining-upward sequence of clean sand, underlain by coarse sand and pebbles.

According to ATC (2004b), the Torrey Sandstone in the bluff outcrop consisted of indurated yellowish brown and grayish brown silty and clayey fine-grained sandstone with occasional, local interbeds and/or lenses of siltstone and claystone. ATC indicated the Torrey Sandstone was generally massive but included distinct cross bedding.

In regards to geologic structures within the Bay Point Formation and Torrey Sandstone, ATC stated that the geologic maps and documents they reviewed described Bay Point Formation bedding as nearly horizontal. Based on their observations, ATC reported that Torrey Sandstone bedding was mostly subhorizontal with a localized siltstone/claystone bed inclined 4 degrees to the northeast. ATC also observed steeply inclined fractures and joints within the Torrey Sandstone that trend at an oblique angle relative to the orientation of the coastal bluff.

ATC did not encounter evidence of groundwater in their borings to the explored depths. They did, however, observe minor to moderate groundwater seepage emanating from siltstone/claystone bedding within the Torrey Sandstone, near the base of the north-facing bluff descending toward Fletcher Cove, and along soil contacts within the west-facing bluff outcrop, west of the Marine Safety Department headquarters. In addition, ATC observed minor groundwater seepage emanating from the westerly exposed surfaces of the existing sea cave infill and from the upper portion of a fracture coincident with the sea cave. ATC opined that groundwater seepage may be originating from tidal water entering joints and fractures, and possibly infiltrated irrigation and storm runoff from inland sites. ATC also stated that the groundwater was likely migrating along zones of contrasting permeabilities, such as geologic contacts, fractures, joints, and bedding planes.

ATC's observations along the coastal bluff at the subject site and adjacent areas indicated localized erosion and scouring from wave action, controlled in part by depleted beach sand levels and variable cementation, and discontinuities within the Torrey Sandstone, exposed in the sea cliff. ATC indicated that marine erosion created nips or sea caves within the lower approximately 10 feet of the sea cliff, reducing support of the overlying materials and increasing the risks of bluff failure/collapse.

As part of their study, ATC evaluated geologic and seismic hazards that could affect the subject property. They concluded that the subject site was susceptible to severe ground shaking resulting from the maximum credible earthquake occurring on the nearby Rose Canyon fault. In addition, ATC surmised that the risks to the coastal bluff at the subject site and the proximal existing structures from landslides was moderate to high. ATC determined that the risks from secondary seismic hazards, such as liquefaction, lateral spreading, and seismic settlement, were relatively low.

In regards to coastal bluff retreat, ATC (2004b) concluded that the "normal" bluff erosion rate at the subject site is on the order of 0.2 to 0.4 feet per year (ft/yr). However, due to the episodic nature of bluff retreat, which is often influenced by meteorological, tidal, wave, and site-specific conditions, ATC suggested that periods of accelerated bluff retreat are likely, especially when moderate to significant undercutting along the toe of the bluff coincides with depleted beach sand levels, as was the case at the time of their 2004 investigation.

Based on their observations, ATC surmised that there was significant likelihood for bluff failures to occur where undercutting and sea cave formation were present along the onsite coastal bluff. ATC admonished that if left unmitigated, the marine erosion impacting the basal portion of the onsite coastal bluff presented a real and imminent threat to Building 3, the public access corridor that services the Las Brisas Condominiums development and the adjacent Surfsong Condominiums development to the south, and the fire access road that provides ingress/egress for fire suppression equipment, along the southern side of the Las Brisas Condominiums property. Given these factors, ATC (2004b) stated that the observed conditions within the onsite coastal bluff jeopardized the health and safety of the beach-going public, pedestrians traveling along the public-access corridor, and the stability of Building 3.

To support their conclusions pertaining to the perilous conditions at the subject property, ATC performed quantitative slope stability analyses along five (5) representative geologic cross sections. Of the five sections, Geologic Cross Sections A-A', B-B', and C-C' traversed the coastal bluff and Building 3. The results of these analyses showed that the static factors-of-safety (FOS) for the most critical theorized failure surfaces ranged between 1.07 and 1.33, with the lowest FOS occurring along ATC's Geologic Cross Section A-A', which was located near the southern end of the aforementioned building.

For mitigation, ATC recommended two (2) alternative remedial measures. One alternative involved infilling the undercut portions and sea caves within the lower bluff with erodible concrete. The second alternative included similar infill of the undercut areas and sea caves, and the construction of an approximately 120-foot long seawall extending to elevation 35 feet MSL. The second alternative would also include a subdrain system to reduce the buildup of hydrostatic pressure behind the seawall. ATC considered the seawall alternative to be the more effective form of mitigation.

As requested by the City of Solana Beach, GSI performed a third-party review of ATC (2004b) and the undated seawall plans prepared by Soil Engineering Construction, Inc. (SEC), in which we provided review comments specific to ATC (2004) and SEC's plans (GSI, 2004b). Following our reviews of the responses by ATC (ATC, 2004a) and plan corrections by SEC (SEC, 2004), we concluded that ATC's geotechnical studies fulfilled the requirements of the Solana Beach Municipal Code (GSI, 2004a), and SEC's seawall plans were in conformance with ATC's recommendations (GSI, 2006).

In 2020, TCG evaluated coastal bluff stability at the subject property in response to the aforementioned progressive bluff failures occurring near the southwestern property corner (TCG, 2020b). TCG's study included several site inspections that involved mapping the approximate limits of the slope failure on PLS&A (2020) and reconstructing the approximate bluff contours to reflect the failure limits, as they existed during their initial site inspection on April 16, 2020.

TCG also performed quantitative slope stability analyses using representative geologic cross sections traversing the bluff failure. These analyses demonstrated that the coastal bluff failure reduced the static global stability factor-of-safety (FOS) of the existing public easement/public agency vehicle access and the southwest corner of Building 3 to as low as 1.021 and 1.231, respectively. Since these static global stability FOS were below the generally recognized acceptable static short-term (temporary) global stability FOS of 1.25, TCG admonished that the southwest corner of the condominium structure could be imminently threatened following a single additional failure event. Given the results of their analyses, TCG recommended that the Las Brisas Condominiums Homeowner's Association (HOA) begin the process of acquiring the necessary permits to construct a "caisson/grade beam/tieback lateral wall that would extend up the coastal bluff from the southern terminus of the existing permitted seawall to the top of the bluff. TCG's letter report dated September 25, 2020 (TCG, 2020b) provided a summary of their coastal bluff stability evaluation.

TCG also prepared conceptual plans illustrating their proposed wall design (TCG, 2020a). This wall concept included the installation of nine (9), 30-inch diameter, reinforced cast-in-drilled-hole (CIDH) concrete piles with a reinforced structural concrete wall facing between and in front of the southern sides of the piles. The wall would extend through the failure area from the southern terminus of the existing seawall to the top of the coastal bluff. One (1) additional CIDH pile would be installed east of the bluff failure for future

maintenance/repair purposes. The exposed concrete wall facing would be textured and colored to resemble the nearby coastal bluffs. The failed bluff area to the north of the piles and concrete wall facing would be regraded to an approximate 1:1 (h:v) or flatter gradient using geogrid reinforcement. The temporary working bench, immediately south of the proposed wall, would be restored via grading to roughly match the adjacent topographic conditions to the south.

RECENT FIELD STUDIES

On May 26, 2021, a GSI representative visited the subject site to map the approximate location of the coastal bluff edge. GSI returned to the site on June 30, 2021 to perform geologic mapping of the coastal bluff in the vicinity of the bluff failure near the southwestern property corner. In addition, in preparation of a separate geotechnical study, GSI advanced two (2) borings near the southeastern corner of the westernmost condominium building on June 2, 2021. Our interpreted coastal bluff edge location, the geologic conditions exposed in the coastal bluff, and the approximate locations of the aforementioned borings are shown in plan view on Plate 1 (Geotechnical Map), which uses PLS&A (2020) as a base. The geologic conditions within the failed portion of the coastal bluff are also shown in profile on Plate 2 (Geologic Cross Sections A-A' and B-B'). Logs of pertinent ATC (2004b) and GSI borings are included in Appendix B.

GEOLOGIC CONDITIONS IN THE VICINITY OF THE SOUTHWESTERN CORNER OF THE LAS BRISAS CONDOMINIUMS PROPERTY

Our observations along the portion of the coastal bluff in proximity to the southwestern corner of the subject site indicated that the geologic conditions therein are generally similar to those described in ATC (2004b). We observed the Torrey Sandstone (Map Symbol - Tt) below approximate elevation 30 feet NAVD88 and old paralic deposits between approximate elevations 30 feet and 87 feet NAVD88. Transient beach deposits (Map Symbol - Qb) occur along the shoreline, seaward of the coastal bluff. The existing seawall (Map Symbol - Afw) and the overlying geogrid-reinforced fill (Map Symbol - Afr) occur along the basal portion of the coastal bluff, to the north of the bluff failure. A relatively thin layer of older artificial fill (Map Symbol - Afo), possibly associated with the original grading of the Las Brisas Condominiums property, was encountered at the surface in our Boring B-1. Based on its placement atop colluvial soils (Map Symbol - Qcol) and possible asphaltic concrete pavement, the older artificial fill may have not been intended for engineering purposes.

Based on our observations of the geologic conditions exposed along the failure scarp, it is our opinion that the old paralic deposits may be subdivided into four (4) parts or subunits. From top to bottom these include an approximately 12-foot thick, near-vertical section of partially cemented, iron-oxide stained silty to clayey sand (Map Symbol - Qop₄),

an approximately 25-foot thick section of friable, poorly graded sand (Map Symbol - Qop₃), an approximately 12-foot thick, near-vertical section of silty sand (Map Symbol - Qop₂), and an approximately 8-foot thick section of friable, poorly graded sand (Map Symbol - Qop₁).

The Torrey Sandstone exposed in the sea cliff portion of the coastal bluff generally consisted of silty sandstone. The Torrey Sandstone included a localized siltstone bed roughly oriented N 60° W and dipping approximately 10 degrees to the southwest.

There were no indications of groundwater exiting the coastal bluff during our field mapping. The elevation of the regional groundwater table is inferred to be generally coincident with sea level or approximately NAVD88.

UPDATED SEISMIC SHAKING PARAMETERS

The following table summarizes the updated site-specific seismic design criteria obtained from the 2019 CBC, Chapter 16 Structural Design, Section 1613, Earthquake Loads and American Society of Civil Engineers (ASCE) 7-16 (ASCE, 2017). The computer program Seismic Design Maps, provided by the California Office of Statewide Health Planning and Development (OSHPD) and the Structural Engineers Association of California (SEAOC) has been used to assist in the design (<https://seismicmaps.org>). The short spectral response utilizes a period of 0.2 seconds. Based on our understanding of the subsurface setting, it is our opinion that Site Class “D” conditions exist within the study area.

2019 CBC SEISMIC DESIGN PARAMETERS			
PARAMETER	VALUE per OSHPD/SEAOC SEISMIC DESIGN MAPS	VALUE per ASCE 7-16	2019 CBC or REFERENCE
Risk Category ⁽¹⁾	II	II	Table 1604.5
Site Class	D	D	Section 1613.2.2/Chap. 20 ASCE 7-16 (p. 203-204)
Spectral Response - (0.2 sec), S _s	1.240 g	0.911 g	Section 1613.2.1 Figure 1613.2.1 ⁽¹⁾
Spectral Response - (1 sec), S ₁	0.440 g	0.751 g	Section 1613.2.1 Figure 1613.2.1 ⁽²⁾
Site Coefficient, F _a	1.2	1.0	Table 1613.2.3 ⁽¹⁾
Site Coefficient, F _v	null - see Section 11.48 ASCE 7-16	2.5 ⁽²⁾ (Section 21.3)	Table 1613.2.3 ⁽²⁾
Maximum Considered Earthquake Spectral Response Acceleration (0.2 sec), S _{MS}	1.488 g	1.40 g ⁽³⁾ (Section 21.4)	Section 1613.2.3 (Eqn 16-36)

2019 CBC SEISMIC DESIGN PARAMETERS			
PARAMETER	VALUE per OSHPD/SEAOC SEISMIC DESIGN MAPS	VALUE per ASCE 7-16	2019 CBC or REFERENCE
Maximum Considered Earthquake Spectral Response Acceleration (1 sec), S_{M1}	null - see Section 11.48 ASCE 7-16	1.20 g ⁽⁴⁾ (Section 21.4)	Section 1613.2.3 (Eqn 16-37)
5% Damped Design Spectral Response Acceleration (0.2 sec), S_{D5}	0.992 g	0.933 g ⁽⁵⁾	Section 1613.2.4 (Eqn 16-38)
5% Damped Design Spectral Response Acceleration (1 sec), S_{D1}	null - see Section 11.48 ASCE 7-16	0.798 g ⁽⁶⁾ (Section 21.4)	Section 1613.2.4 (Eqn 16-39)
PGA_M - Probabilistic Vertical Ground Acceleration may be assumed as about 50% of these values.	0.67 g	0.608 g-	ASCE 7-16 (Eqn 11.8-1)
Seismic Design Category	null - see Section 11.48 ASCE 7-16	D ⁽⁷⁾ (Section 11.6)	Section 1613.2.5/ASCE 7-16 (p. 85: Table 11.6-1 or 11.6-2)
1. Risk Category to be confirmed by the Project Architect. 2. Per Table 11.4-1 of ASCE 7-16, since $S_1 \geq 0.2$, F_v is taken as 2.5. 3. Per Section 21.4 of ASCE 7-16, $S_{M5} = (1.5)(S_{D5}) = (1.5)(0.933 \text{ g}) = 1.40 \text{ g}$ 4. Per Section 21.4 of ASCE 7-16, $S_{M1} = (1.5)(S_{D1}) = (1.5)(0.798 \text{ g}) = 1.20 \text{ g}$ 5. Per Section 21.4 of ASCE 7-16, S_{D5} shall be taken as 90 percent of the maximum spectral acceleration (S_a) obtained from the site-specific spectrum at any period within the range from 0.2 to 5 seconds, inclusive. 6. Per Section 21.4 of ASCE 7-16, S_{D1} shall be taken as the maximum value of the product TS_a obtained from the site-specific spectrum from the period within the range of 1 to 5 seconds, inclusive. 7. Per Table 11.6-1 of ASCE 7-16, $0.50 \text{ g} \leq SD_s \leq 0.50 \text{ g} \leq 0.933 \text{ g}$. Thus, the site is within Seismic Design Category "D."			

Conformance to the criteria above for seismic design does not constitute any kind of guarantee or assurance that significant structural damage or ground failure will not occur in the event of a large earthquake. The primary goal of seismic design is to protect life, not to eliminate all damage, since such design may be economically prohibitive. Cumulative effects of seismic events are not addressed in the 2019 CBC (CBSC, 2019) and regular maintenance and repair following locally significant seismic events (i.e., $M_w 5.5$) will likely be necessary.

COASTAL BLUFF GEOMORPHOLOGY

The typical coastal-bluff profile may be divided into three zones: the shore platform; a lower near-vertical cliff surface termed the sea cliff; and an upper-bluff slope generally ranging in inclination between about 20 and 80 degrees (measured from the horizontal). The bluff top or bluff edge is the boundary between the upper bluff slope and the relatively flat lying to gently sloping coastal terrace.

Offshore from the sea cliff is an area of indefinite extent termed the near-shore zone. The bedrock surface in the near-shore zone, which extends out to sea from the base of the sea cliff, is the shore platform. As pointed out by Trenhaile (1987), worldwide, the shore platform may vary in inclination from near horizontal to as steep as 3:1 (h:v). In the

Encinitas and Solana Beach areas, the shore platform extends 500 to 900 feet offshore at a 1 to 2 percent slope (United States Army Corps of Engineers [USACE], 2015). The boundary between the sea cliff and the shore platform is called the cliff-platform junction, or sometimes the shoreline angle. Within the near-shore zone, is a subdivision called the inshore zone, where the waves begin to break. This boundary varies with time because the point at which waves begin to break changes dramatically with changes in wave size and tidal level. During low tides, large waves will begin to break further away from shore. During high tides, waves may not break at all, or they may break directly on the lower sea cliff. Closer to shore is the foreshore zone, or the portion of the shoreline lying between the upper limit of wave wash at high tide and the ordinary low water mark. Both of these boundaries often lie on a sand or cobble beach. In this case, a shoreline with a bluff, the foreshore zone extends from low water to the lower face of the bluff.

Emery and Kuhn (1982) developed a global system of classification of coastal bluff profiles, and applied that system to the San Diego County coastline from San Onofre State Park to the southerly tip of Point Loma. Emery and Kuhn (1982) designated the Solana Beach coastline as “active” and “Type A-c.” The letter “A” designates coastal bluffs having a homogeneous geologic formation along the base of the bluff and in the upper portions of the bluff. The relative effectiveness of marine erosion compared to subaerial erosion of the bluff produces a characteristic profile. The letter “c” indicates that the long-term rate of marine erosion is approximately equal to that of subaerial erosion.

SLOPE STABILITY ANALYSIS

GSI performed quantitative slope stability analysis to evaluate the existing, global static factor-of-safety of Building 3, in light of the nearby bluff failure. The geologic conditions shown on Geologic Cross Section A-A' were used as a model in the analysis, since this traverse represents the closest distance between the bluff edge (top of the failure head scarp) and the foundation of Building 3. The two-dimensional slope stability analysis software program “GEOSTASE” version 4.30.31, developed by Gregory (2018), facilitated the quantitative slope stability analysis. For more information regarding the “GEOSTASE” slope stability analysis software program, please refer to the user manual available on the Gregory Geotechnical, Geotechnical Engineering and Consulting website (<https://www.gregeo.com/software/>).

For the analysis, we incorporated a distributed load of 250 pounds per square foot (psf) to simulate surcharge applied by heavy axle (HS20) vehicles, such as fire suppression equipment within the emergency vehicle access road (fire access road), near the southwest corner of the Las Brisas Condominiums property. We also applied a 3,000 psf distributed load to replicate surcharge from Building 3. The soil strengths modeled in our analyses were based on the results of shear testing performed by ATC (2004b) and GSI (see Appendix C), as well as our professional judgement. Isotropic soil strengths were applied to all geologic units included in the analyses.

GSI searched for theoretical failure surfaces within the Quaternary-age old paralic deposits in the upper bluff, since progressive retreat of the existing failure scarp is the most likely bluff failure mechanism in the near term. Given the modeled failure mechanics, our analysis did not consider every geologic unit and corresponding soil strength entered into “GEOSTASE”.

The following table summarizes the soil strengths assigned to the geologic units entered into the analysis:

SOIL MATERIALS	SOIL UNIT WEIGHT (pounds per cubic foot [pcf])		SHEAR STRENGTH PARAMETERS	
	Moist	Saturated	C (psf)	Φ (degrees)
Quaternary Beach Deposits (Qb)	105	110	0	33
Artificial Fill - Older (Afo)	110	N/A	50	32
Quaternary Colluvium (Qcol)	105	N/A	50	29
Weathered Quaternary Old Paralic Deposits - Subunit 4 (Qop)	108	N/A	100	30
Quaternary Old Paralic Deposits - Subunit 4 (Qop4)	114	N/A	230	32
Quaternary Old Paralic Deposits - Subunit 3 (Qop3)	107	N/A	190	34
Quaternary Old Paralic Deposits - Subunit 2 (Qop2)	105	N/A	150	40
Quaternary Old Paralic Deposits - Subunit 1 (Qop1)	107	N/A	50	33
Tertiary Torrey Sandstone (Tt)	102	N/A	290	37

Our search for theoretical failure surfaces in the upper bluff was initiated within Subunit 1 of the old paralic deposits (Map Symbol - Qop₁) and terminated within the footprint of Building 3. Slope stability was analyzed using Spencer’s Method to satisfy all conditions of force and moment equilibrium. GSI allowed “GEOSTASE” to search for 4,999 potential theoretical failure planes.

The results of the analysis are shown on Plate D-1 (Appendix D), and indicate that the theoretical failure surface with a static factor-of-safety (FOS) equal to 1.19 would daylight the ground surface within the footprint of Building 3. Thus, our global stability analysis indicates that the southwestern corner of Building 3 is subject to impending catastrophic failure unless remedial measures are undertaken in the near term. An additional failure of

the head scarp that results in the loss of several feet of land between the scarp and the seaward foundation of Building 3 has high potential to trigger such an event. Similarly, portions of the existing fire access road, near the failure head scarp are also subject to imminent failure. Failure of this road could present a danger to the life and safety of the building occupants if fire suppression and rescue equipment are unable to travel along the designated pathway.

PRELIMINARY CONCLUSIONS AND RECOMMENDATIONS

As previously stated, the southwestern corner of Building 3 and the existing fire access road have been imperiled by the nearby bluff failure. Thus, emergency measures should be taken to stabilize the failed portion of the coastal bluff.

The Las Brisas Condominiums HOA has retained the services of the design-build consultant Geostabilization International (GI) to develop a plan to stabilize the failed portion of the coastal bluff. This plan (GI, 2021a, 2021b) includes remedial measures similar to those proposed by TCG (2020a). However, rather than supporting the shotcrete wall by CIDH piles, GI is proposing to use an array of 51 micropiles for the wall foundation. Each micropile will extend a minimum of 5 feet into the Torrey Sandstone. The wall would retain a reinforced soil slope that restores the failed portion of the bluff to its north side.

GSI has performed a review of GI (2021b) and the supporting calculations included in GI (2021a). Based on our review, the proposed mitigation would return the static and seismic global FOS of Building 3 to at least 1.5 and 1.1, respectively. It is our opinion that GI has used reasonably conservative parameters for soil strengths and seismic loading in their slope stability and structural analyses.

FINAL PLAN REVIEW

As the Geotechnical Consultant-of-Record, GSI should perform a final geotechnical review of the bluff stabilization plans and supporting structural calculations, following review by the regulatory agencies.

RESPONSES TO CTE (2021)

Based on our review of CTE (2021), GSI understands that it is our responsibility to respond to comment nos. 2, 5, 7, and 8a. The CTE (2021) review comments requiring our attention are repeated below in *italics*, followed by our response.

CTE Comment No. 2

Per the permit application, question 5, please provide a geotechnical report prepared to meet the requirements of the City and the California Coastal Commission (CCC) signed and stamped by both a Registered Civil Engineer (RCE) and Certified Engineering Geologist (CEG). A previously prepared geotechnical report associated with the previous wall construction, updated to current standard of practice and signed and stamped by a RCE and CEG, may be suitable.

GSI Response to CTE Comment No. 2

GSI respectfully refers the reviewer to the geotechnical update evaluation that precedes this response.

CTE Comment No. 5

Please provide a site plan and geologic cross-section of the existing slope failure that depicts the underlying geology; the limits of the public access easement; the seaward side of the nearest principal structure foundational element; and verified top-of-bluff and corresponding minimum setbacks.

GSI Response to CTE Comment No. 5

GSI respectfully directs the reviewer to the attached Plates 1 and 2.

CTE Comment No. 7

Noting that the LCP defines City Infrastructure as “City owned roads and City owned utilities located therein and thereon,” please comment as to whether a bluff failure is imminent that would threaten city infrastructure and/or a principal structure with danger from erosion, per LCP Policy 4.52(a)(1). Additionally, please comment as to whether city infrastructure and/or a principal structure is more likely than not to be in danger within approximately one year, per LCP Policy 4.52(a)(2).

GSI Response to CTE Comment No. 7

As stated previously in this report, our global slope stability analyses indicates that the southwestern corner of Building 3 currently has a static FOS of 1.19. This is less than the static short-term FOS of 1.25 recognized by major municipalities in southern California (City of San Diego, 2018; City of Los Angeles Department of Building and Safety, 2020). Thus, it is our opinion that the southwestern corner of Building 3 is in danger of structural damage at this time. In addition, the slope stability analyses indicate that the fire access road for fire suppression and rescue equipment, adjacent to the top of the failure scarp, is also threatened at this time. A failure of this road could limit access of such emergency vehicles, which presents a life and safety issue to the occupants of Building 3.

CTE Comment No. 8

Please address the proposed project's impact on the southerly neighbor, including but not limited to:

- a. *What impact will the proposed wall have on the future erosion of the remaining exposed scarp on the southerly neighbor's property?*

GSI Response to CTE Comment No. 8a

The proposed mitigation shown on GI (2021b) will have no impact on the future erosion of the remaining exposed scarp on the southerly neighbor's property (i.e., Surfsong Condominiums). The proposed bluff restoration and protective measures do not extend to the south of the Las Brisas Condominiums' property, since the adjacent Surfsong Condominiums HOA does not want to participate in the repair at this time. Thus, the remaining exposed failure scarp, located on the adjacent Surfsong Condominiums' property, will be subject to additional headward retreat. As indicated on Sheet C-11 of GI (2021b), additional reinforced shotcrete and bluff stabilization will be required to mitigate global failure of the cutoff wall should erosion on the Surfsong Condominium's property expose 6 feet or more of the micropiles below the base of the shotcrete facing and/or if the reinforced soil slope backfill begins to run between the micropiles.

LIMITATIONS

The materials encountered on the project site and utilized for our analysis are believed representative of the area; however, soil and bedrock materials vary in character between excavations and natural outcrops or conditions exposed during mass grading. Site conditions may vary due to seasonal changes or other factors.

Inasmuch as our study is based upon our review and engineering analyses and laboratory data, the conclusions and recommendations are professional opinions. These opinions have been derived in accordance with current standards of practice, and no warranty, either express or implied, is given. Standards of practice are subject to change with time. GSI assumes no responsibility or liability for work or testing performed by others, or their inaction; or work performed when GSI is not requested to be onsite, to evaluate if our recommendations have been properly implemented. Use of this report constitutes an agreement and consent by the user to all the limitations outlined above, notwithstanding any other agreements that may be in place. In addition, this report may be subject to review by the controlling authorities. Thus, this report brings to completion our scope of services for this portion of the project.

The opportunity to be of service is sincerely appreciated. If you should have any questions, please do not hesitate to contact our office.

Respectfully submitted,

GeoSoils, Inc.



Robert G. Crisman
Engineering Geologist, CEG 1934



Stephen J. Coover
Geotechnical Engineer, GE 2057



Ryan B. Boehmer
Staff Geologist

RBB/RGC/SJC/sh

Attachments: Appendix A - References
Appendix B - GSI and ATC (2004b) Boring Logs
Appendix C - GSI and ATC (2004b) Shear Strength Test Results
Appendix D - Slope Stability Analysis
Plate 1 - Geotechnical Map
Plate 2 - Geologic Cross Sections A-A' and B-B'

Distribution: (1) Addressee (PDF via email)

APPENDIX A

REFERENCES

APPENDIX A

REFERENCES

Anthony-Taylor Consultants, 2004a, Response to third-party geotechnical review, emergency permit request, Las Brisas Condominiums, 135 South Sierra Avenue, Solana Beach, California, project no.: 03-2283, dated October 4.

_____, 2004b, Geotechnical/geologic evaluation, bluff conditions, Las Brisas Condominiums, 135 South Sierra Avenue, Solana Beach, California 92076, project no.: 03-2283, dated June 22.

City of San Diego, 2018, Guidelines for geotechnical reports, 2018.

City of Los Angeles Department of Building and Safety, 2020, Construction upon slopes steeper than two horizontal to one vertical, information bulletin / public - building code, reference no.: LABC 7014.1, document no.: P/BC 2020-050, dated January 1.

Construction Testing and Engineering, Inc., 2021, Application submittal geotechnical review, Las Brisas Condominiums, 135 South Sierra Avenue, Solana Beach, California 92075, CTE job no: 10-15983G, dated March 7.

Emery, K.O., and Kuhn, G.G., 1982, Sea cliffs: their processes, profiles, and classification: Geological Society of America Bulletin, v. 93, no 7.

GeoSoils, Inc., 2006, Final geotechnical review of plans for shoreline stabilization project, 135 South Sierra Avenue, Solana Beach, San Diego County, California, W.O. 4458-A-SC, dated September 5.

_____, Supplemental geotechnical review of documents pertaining to the proposed shoreline stabilization project, 135 South Sierra Avenue, Solana Beach, San Diego County, California, W.O. 4458-A-SC, dated October 22.

_____, 2004b, Preliminary geotechnical review of documents pertaining to the proposed shoreline stabilization project, 135 South Sierra Avenue, Solana Beach, San Diego County, California, W.O. 4458-A-SC, dated July 27.

Geostabilization International, 2021a, Las Brisas Condominiums bluff stabilization engineering design submittal, dated October 21.

_____, 2021b, Bluff stabilization plans, Las Brisas Condominiums, City of Solana Beach, CA, Las Brisas HOA, 14 sheets, various scales, project no. 210487CA01, dated September 27.

Gregory, G.H., 2019, GEOSTASE slope stability analysis program; Version 4.30.31.

- Kennedy, M.P., 1975, Geology of the San Diego metropolitan area, California: California Division of Mines and Geology, Bulletin 200, Section A, Western San Diego Metropolitan Area, Del Mar, La Jolla, and Point Loma, 7½ minute quadrangles.
- Kennedy, M.P., and Tan, S.S., 2008, Geologic map of the San Diego 30' by 60' quadrangle, California, Map no. 3, scale 1:100,000, California Geologic Survey and U.S. Geologic Survey.
- Krinitzsky, E.L., Gould, J.P., and Edinger, P.H., 1993, Fundamentals of earthquake resistant construction: John H. Wiley & Sons, Inc., 299 p.
- Pasco, Laret, Suiter, & Associates, 2020, Topographic survey map, Las Brisas, 135 S. Sierra Ave., 2 sheets, various scales, PLSA job no.: 2710, dated January 13.
- Structural Engineers Association of California and California Office of Statewide Health Planning and Development, 2019, Seismic design maps, <https://seismicmaps.org/>
- Tan, S.S., and Giffen, D.G., 1995, Landslide hazards in the northern part of the San Diego Metropolitan area, San Diego County, California, Landslide hazard identification map no. 35, Plate 35G, Department of Conservation, Division of Mines and Geology, DMG Open File Report 95-04.
- Taniguchi, E., and Sasaki, Y., 1986, Back analysis of landslide due to Naganoken Seibu Earthquake of September 14, 1984; Proceedings, XI ISSMFE Conference, Session 7B, San Francisco, California. Rolla, MO: University of Missouri.
- TerraCosta Consulting Group, 2020a, Plans for: Las Brisas Condominiums bluff stabilization, 5 sheets, various scales, project no.: 1848-02, dated September 28.
- _____, 2020b, Coastal bluff evaluation/project recommendations, Las Brisas Condominiums, 135 South Sierra Avenue, Solana Beach, California, project no.: 1848-02, dated September 25.
- Trenhaile, A.S., 1987, The geomorphology of rock coasts: Clarendon Press, Oxford.
- The Trettin Company, 2020, Application for Conditional Use Permit amendment, coastal bluff failure repair, Las Brisas Condominiums, dated December 16.
- United States Army Corps of Engineers, 2015, Encinitas-Solana Beach coastal storm damage reduction project integrated feasibility study, dated April.
- United States Geological Survey, 1994, Topographic survey of the Del Mar quadrangle, 7.5-minute series, 1:24,000-scale.

APPENDIX B

GSI AND ATC (2004b) BORING LOGS

UNIFIED SOIL CLASSIFICATION SYSTEM				CONSISTENCY OR RELATIVE DENSITY														
Major Divisions			Group Symbols	Typical Names		CRITERIA												
Coarse-Grained Soils More than 50% retained on No. 200 sieve	Gravels 50% or more of coarse fraction retained on No. 4 sieve	Clean Gravels	GW	Well-graded gravels and gravel-sand mixtures, little or no fines		<p align="center">Standard Penetration Test</p> <table border="0"> <tr> <td>Penetration Resistance N (blows/ft)</td> <td>Relative Density</td> </tr> <tr> <td>0 - 4</td> <td>Very loose</td> </tr> <tr> <td>4 - 10</td> <td>Loose</td> </tr> <tr> <td>10 - 30</td> <td>Medium</td> </tr> <tr> <td>30 - 50</td> <td>Dense</td> </tr> <tr> <td>> 50</td> <td>Very dense</td> </tr> </table>	Penetration Resistance N (blows/ft)	Relative Density	0 - 4	Very loose	4 - 10	Loose	10 - 30	Medium	30 - 50	Dense	> 50	Very dense
			Penetration Resistance N (blows/ft)	Relative Density														
		0 - 4	Very loose															
		4 - 10	Loose															
	10 - 30	Medium																
	30 - 50	Dense																
	> 50	Very dense																
	GP	Poorly graded gravels and gravel-sand mixtures, little or no fines																
	Gravel with	GM	Silty gravels gravel-sand-silt mixtures															
		GC	Clayey gravels, gravel-sand-clay mixtures															
Sands more than 50% of coarse fraction passes No. 4 sieve	Clean Sands	SW	Well-graded sands and gravelly sands, little or no fines															
		SP	Poorly graded sands and gravelly sands, little or no fines															
	Sands with Fines	SM	Silty sands, sand-silt mixtures															
		SC	Clayey sands, sand-clay mixtures															

Unified Soil Classification	Cobbles	Gravel		Sand			Silt or Clay
		coarse	fine	coarse	medium	fine	
		3"	3/4"	#4	#10	#40	#200 U.S. Standard Sieve

<u>MOISTURE CONDITIONS</u>		<u>MATERIAL QUANTITY</u>		<u>OTHER SYMBOLS</u>	
Dry	Absence of moisture: dusty, dry to the touch	trace	0 - 5 %	C	Core Sample
Slightly Moist	Below optimum moisture content for compaction	few	5 - 10 %	S	SPT Sample
Moist	Near optimum moisture content	little	10 - 25 %	B	Bulk Sample
Very Moist	Above optimum moisture content	some	25 - 45 %	•	Groundwater
Wet	Visible free water; below water table			Qp	Pocket Penetrometer

BASIC LOG FORMAT:
Group name, Group symbol, (grain size), color, moisture, consistency or relative density. Additional comments: odor, presence of roots, mica, gypsum, coarse grained particles, etc.

EXAMPLE:
Sand (SP), fine to medium grained, brown, moist, loose, trace silt, little fine gravel, few cobbles up to 4" in size, some hair roots and rootlets.

GeoSoils, Inc.

BORING LOG

PROJECT: 135 S. SIERRA AVENUE, SOLANA BEACH
92075

W.O. 8157-A-SC BORING B-1 SHEET 1 OF 1

DATE EXCAVATED 6-2-21 LOGGED BY: RB APPROX. ELEV.: ±86' NAVD88

SAMPLE METHOD: Modified California Sampler, 140lb Hammer @30-in Drop

Depth (ft.)	Sample			USCS Symbol	Dry Unit Wt. (pcf)	Moisture (%)	Saturation (%)	Material Description
	Bulk	Undisturbed	Blows/Ft.					
0				SP-SM				ARTIFICIAL FILL - OLDER: @ 0', SILTY SAND and SAND, variegated reddish brown, brown, and dark gray, damp, loose; fine to medium grained.
5			12	SP	97.5	5.1	18.7	@ 4', Asphaltic concrete pavement.
			16	SP	105.7	2.7	12.8	QUATERNARY COLLUVIUM: @ 4 1/4', SAND, dark brown, damp, loose; fine to medium grained, trace SILT.
10			27	SM	110.0	5.6	29.4	WEATHERED QUATERNARY OLD PARALIC DEPOSITS: @ 5', SAND, dark yellowish brown, dry, medium dense; fine to medium grained, trace SILT. @ 7', SAND, dark yellowish brown, dry, medium dense.
15			25	SP	108.5	5.6	28.4	QUATERNARY OLD PARALIC DEPOSITS: @ 10 1/3', SILTY SAND, reddish yellow, damp, medium dense; fine grained. @ 12 1/2', SAND, dark yellowish brown, damp, medium dense; fine to medium grained, trace SILT.
			25	SP	110.4	4.5	24.1	@ 14 1/2', SAND, dark yellowish brown and dark gray, dry, medium dense; fine to medium grained.
20			21	SP	97.1	1.5	5.7	@ 18 1/2', SAND, yellowish gray, dry, medium dense; fine to medium grained.
25								Total Depth = Approximately 19 1/2' No Groundwater/No Caving Encountered Backfilled 6-2-21
30								

Standard Penetration Test
 Undisturbed, Ring Sample

Groundwater
 Seepage

GeoSoils, Inc.

BORING LOG

PROJECT: 135 S. SIERRA AVENUE, SOLANA BEACH
92075

W.O. 8157-A-SC BORING B-2 SHEET 1 OF 1

DATE EXCAVATED 6-2-21 LOGGED BY: RB APPROX. ELEV.: ±76' NAVD88

SAMPLE METHOD: Modified California Sampler, 140lb Hammer @30-in Drop

Depth (ft.)	Sample			USCS Symbol	Dry Unit Wt. (pcf)	Moisture (%)	Saturation (%)	Material Description
	Bulk	Undisturbed	Blows/Ft.					
0	█			SP-SM				ARTIFICIAL FILL - OLDER: @ 0', SILTY SAND, dark gray, dry, very loose; very fine grained; trace roots (topsoil).
5	█		16	SP	104.9	2.2	10.0	QUATERNARY OLD PARALIC DEPOSITS: @ 1/2', SAND, dark yellowish brown and dark gray, dry. Becoming damp at approximately 1', loose. Becoming medium dense at approximately 1'; fine grained.
10	█		19	SP	102.3	9.8	2.3	@ 6', SAND, grayish brown and dark gray, dry, medium dense; fine to medium grained, friable.
15	█		23	SP	104.4	2.0	8.9	@ 10', SAND, brownish gray and dark gray, dry, medium dense; fine to medium grained, friable.
20				SP				@ 14 1/2', SAND, brownish gray and dark gray, dry, medium dense; fine to medium grained, friable. @ 15', SAND, yellowish gray and reddish yellow, dry, medium dense; medium to coarse grained, friable.
25								Total Depth = Approximately 15 1/2' No Groundwater Encountered Caving Below Approximately 13' Backfilled 6-2-21
30								

Standard Penetration Test
 Undisturbed, Ring Sample

Groundwater
 Seepage



V. Subsurface Exploration

As part of the site evaluation, we performed four exploratory subsurface soil borings to evaluate the underlying soil materials. Our exploratory test borings were advanced using a combination of the track mounted limited access drill rig, with continuous flight auger with a 140-pound drive hammer (Borings 1 and 2), as well as portable, 5-inch diameter hand auger equipment (Borings 3 and 4). Our exploratory borings were performed on November 28, 2003, at the locations shown on the attached Geologic/Geotechnical Map, Plate 1. A log of the soil conditions encountered within the individual borings is presented below:

Boring No. 1 (B-1)

Soil Conditions Encountered:

Terrace Deposits (Bay Point Formation): Brown to reddish brown, dry to slightly moist, slightly cemented, medium dense to dense, silty fine to medium sand.

@ 2.0': Becomes reddish-brown.

@ 4.5'-5.5': Drive Sample: Blow Counts 15/6" and 19/6", Moisture Content (MC) = 2.6%, Dry Density (DD) = 111.1 pcf.

@ 6.0': Becomes gray-brown to brown, less silty, micaceous.

@ 7.5': Becomes reddish-brown, slightly moist, silty, medium sand.

@ 9.5'-10.5': Drive Sample: Blow Counts 18/6" and 28/6", MC = 5.0 %, DD = 108.1 pcf.

@ 14.5'-15.5': Drive Sample: Blow Counts 19/6" and 24/6", MC = 3.7 %, DD = 112.2 pcf.

@ 17.0': Noticeably easier drilling conditions reported.

@ 19.5'-20.5': Drive Sample: Blow Counts 21/6" and 24/6", MC = 2.3 %, DD = 106.2 pcf.

@ 22.0': Brown to light brown, slightly moist, dense, slightly silty fine to medium sand, dense, friable.

@ 24.5'-25.5': Light brown to light gray, slightly moist, medium dense to dense, clean to slightly silty, fine to medium sand, friable.

Drive Sample: Blow Counts 26/6" and 34/6", MC = 1.4 %, DD = 99.7 pcf.

@ 29.5'-30.5': Light brown to light gray, slightly moist, medium dense to dense, clean, medium sand, friable.

Drive Sample: Blow Counts 34/6" and 38/6", MC = 1.4 %, DD = 104.1 pcf.

@ 34.5'-35.5': Light brown to light gray-brown, slightly moist, medium dense to dense, clean, medium sand, friable.

Drive Sample: Blow Counts 23/6" and 31/6", MC = 1.6 %, DD = 99.1 pcf.



Boring No. 1 (B-1) Continued
Soil Conditions Encountered:

@ 39.5'-40.5': Light brown to light gray-brown, slightly moist, medium dense to dense, clean, medium sand, friable.
Drive Sample: Blow Counts 26/6" and 29/6", MC = 2.0 %, DD = 102.2 pcf.

Total Depth: 40.5 feet.

No Water.

Minor Caving between 35 and 40 feet.

Backfilled with Sand/Bentonite/Water.

No Groundwater Was Encountered.

Boring No. 2 (B-2)
Soil Conditions Encountered:

Landscape Topsoil: Brown to dark brown, wet, loose to medium dense, silty sand.

@ 1.0': **Terrace Deposits (Bay Point Formation):** Brown to reddish brown, moist, medium dense to dense, silty fine to medium sand.

@ 2.0': Becomes reddish-brown.

@ 8.5'-9.5': Drive Sample: Blow Counts 13/6" and 18/6", Moisture Content (MC) = 3.0 %, Dry Density (DD) = 111.5 pcf.

@ 16.5'-17.5': Brown to gray-brown slightly moist to moist, silty fine to medium sand, micaceous, friable. Drive Sample: Blow Counts 12/6" and 16/6", MC = 2.4 %, DD = 104.4 pcf.

@ 24.5'-25.5': Light brown to gray brown slightly moist, medium dense to dense, clean sand, micaceous, friable. Drive Sample: Blow Counts 20/6" and 21/6", MC = 1.4 %, DD = 99.7 pcf.

@ 32.5'-33.5': Drive Sample: Blow Counts 21/6" and 25/6", MC = 2.3 %, DD = 102.1 pcf.

@ 40.5'-41.5': Light brown to light gray, slightly moist, medium dense to dense, clean to slightly silty, fine to medium sand, friable.
Drive Sample: Blow Counts 24/6" and 26/6", MC = 3.7 %, DD = 106.5 pcf.

@ 48.5'-49.5': Gray brown slightly silty, medium dense to dense, slightly silty, fine to medium sand, micaceous. Drive Sample: Blow Counts 24/6" and 50/6". MC = 3.5 %, DD = 103.5 pcf.

@ 56' **Torrey Sandstone Formation:** Light brown to yellowish -brown, silty medium to coarse sandstone, moderately cemented.

@ 56.5'-57.5' Drive Sample: Blow Counts 70/4" MC = 6.1 %, DD = 96.2 pcf.

@ 60.0'-60.5': Drive Sample: Blow Counts 70/3" No Sample Recovery.
Drive Sample: Blow Counts 26/6" and 29/6".

Total Depth: 60.5 feet

No Groundwater Was Encountered

Minor Caving between 25 and 35 feet

Backfilled with Sand/Bentonite/Water.

APPENDIX C

GSI AND ATC (2004b) SHEAR STRENGTH TEST RESULTS

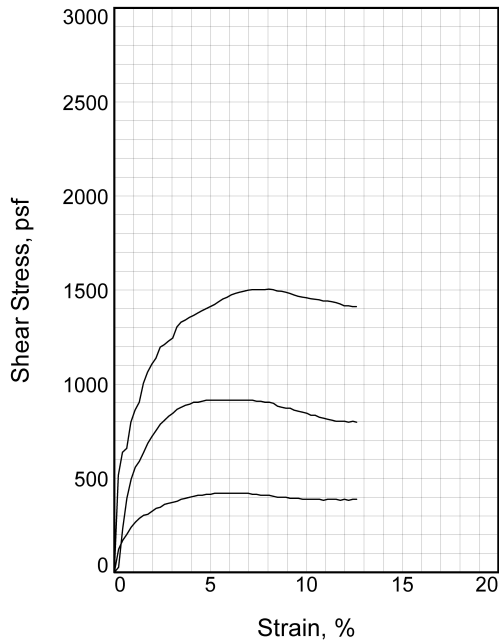
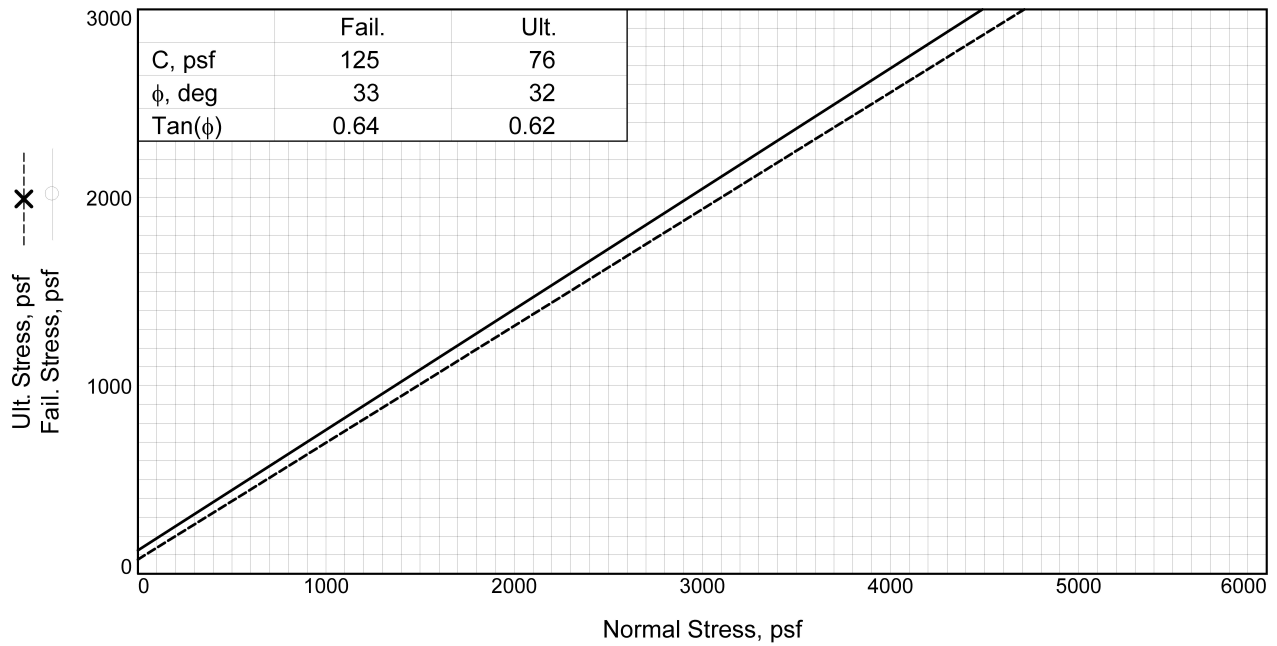

Sample No.	1	2	3	
Initial	Water Content, %	3.2	3.2	8.8
	Dry Density, pcf	98.7	100.3	93.6
	Saturation, %	12.5	13.1	30.4
	Void Ratio	0.6768	0.6490	0.7681
	Diameter, in.	2.38	2.38	2.38
	Height, in.	1.00	1.00	1.00
At Test	Water Content, %	19.3	21.5	21.8
	Dry Density, pcf	98.9	100.8	95.0
	Saturation, %	76.1	88.9	77.9
	Void Ratio	0.6735	0.6407	0.7415
	Diameter, in.	2.38	2.38	2.38
	Height, in.	1.00	1.00	0.98
Normal Stress, psf	550	1100	2200	
Fail. Stress, psf	420	915	1505	
Strain, %	6.1	5.9	8.1	
Ult. Stress, psf	388	803	1427	
Strain, %	9.8	11.5	11.8	
Strain rate, in./min.	0.004	0.005	0.004	

Sample Type: Natural
Description: Reddish Brown Sand w/Silt

Specific Gravity= 2.65
Remarks:

Plate _____

Client: Las Brisas HOA

Project: 135 South Sierra Ave.

Source of Sample: B-1 **Depth:** 5.0

Sample Number: B-1 Proj.

No.: 8157-A-SC

Date Sampled:



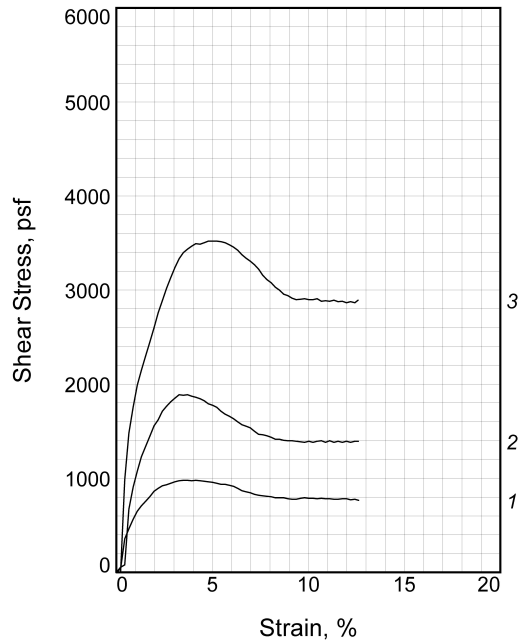
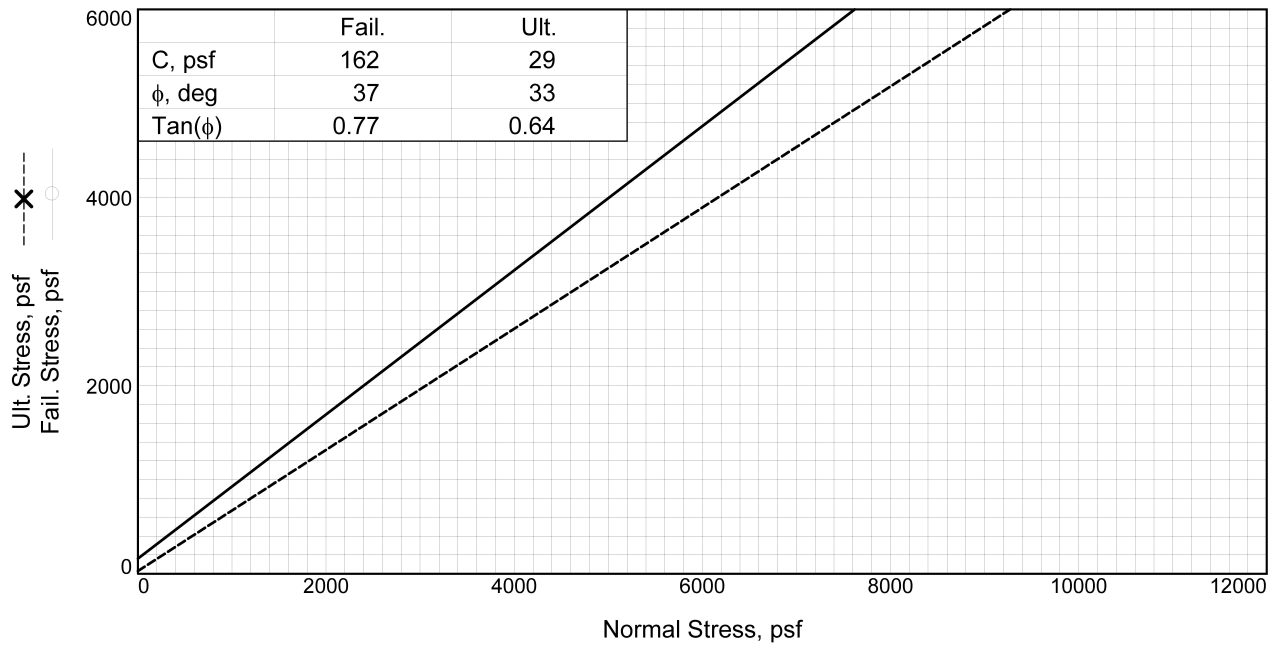

Sample No.	1	2	3	
Initial	Water Content, %	1.5	1.5	1.5
	Dry Density, pcf	97.3	97.4	96.6
	Saturation, %	5.7	5.7	5.6
	Void Ratio	0.7010	0.6980	0.7129
	Diameter, in.	2.38	2.38	2.38
	Height, in.	1.00	1.00	1.00
At Test	Water Content, %	22.9	20.5	22.3
	Dry Density, pcf	97.6	98.0	97.6
	Saturation, %	87.3	78.9	85.0
	Void Ratio	0.6959	0.6878	0.6958
	Diameter, in.	2.38	2.38	2.38
	Height, in.	1.00	0.99	0.99
Normal Stress, psf	1100	2200	4400	
Fail. Stress, psf	978	1888	3520	
Strain, %	3.5	3.3	5.0	
Ult. Stress, psf	776	1388	2882	
Strain, %	9.2	9.6	10.7	
Strain rate, in./min.	0.004	0.004	0.004	

Sample Type: Natural
Description: Pale Yellow Sand w/Silt

Specific Gravity= 2.65
Remarks:

Plate _____

Client: Las Brisas HOA

Project: 135 South Sierra Ave.

Source of Sample: B-1 **Depth:** 18.5

Sample Number: B-1 Proj.

No.: 8157-A-SC

Date Sampled:



DIRECT SHEAR TEST RESULTS

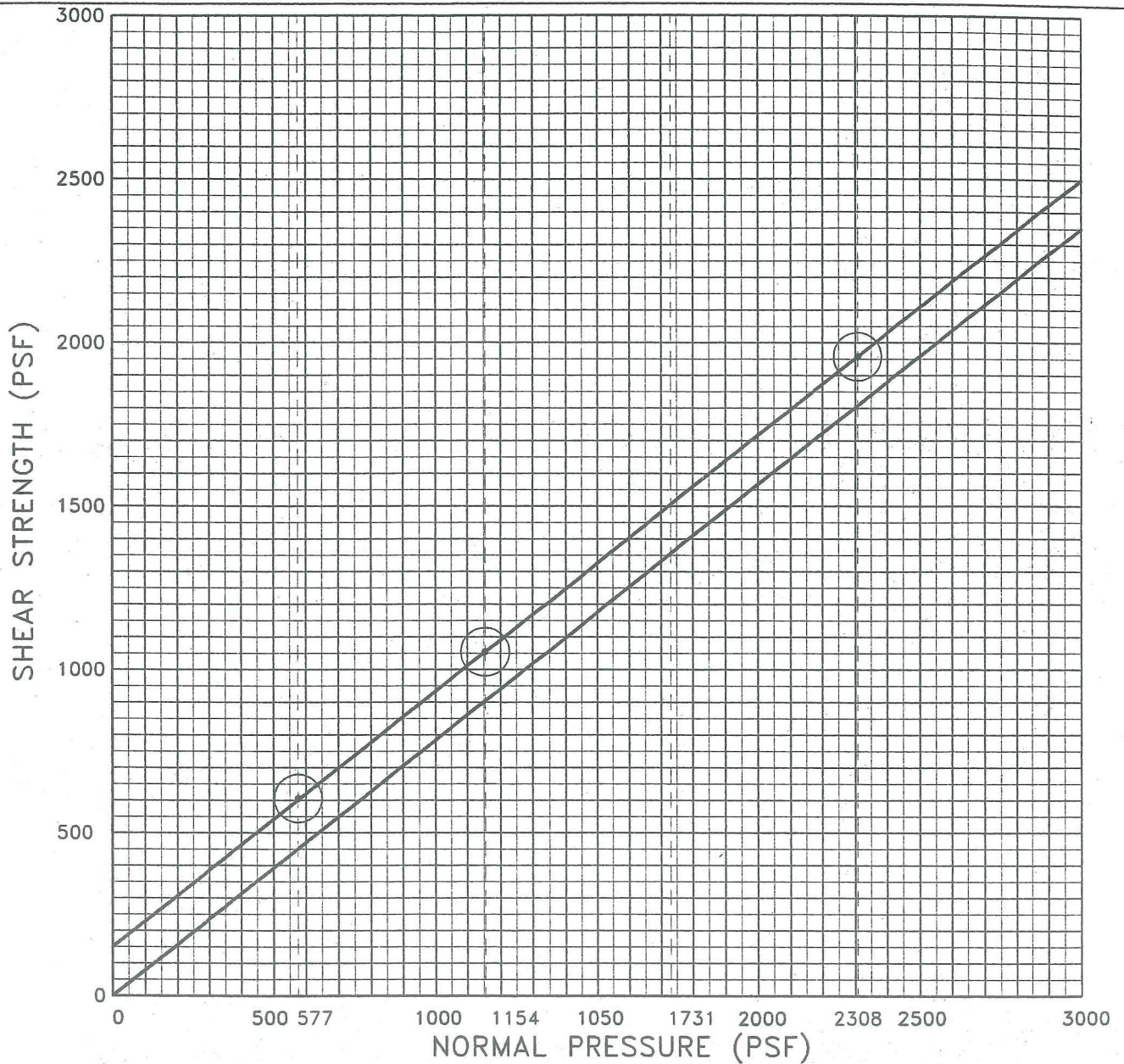

SYMBOL	SAMPLE LOCATION	COHESION (psf)	FRICTION ANGLE (°)	REMARKS
●	B-1 @ 9.5' TO 10.01'	119	39	TERRACE DEPOSITS NATURAL FIELD SHEARS, SATURATED.
	NORMAL PRESSURE (psf)	SHEAR STRENGTH (psf)		
	577	.606		
	1154	1.011		
	2308	1.986		

W.O. 8157-A-SC
PLATE C-3



ANTHONY-TAYLOR CONSULTANTS

San Diego (Corporate), 304 Enterprise Street, Escondido, CA 92029 (760) 738-8800

JOB NAME: LAS BRISAS

SITE ADDRESS: 135 SOUTH SIERRA AVE.
SOLANA BEACH, CA 92075

JOB NUMBER:
03-2283

REVIEWED BY:
DM/HE

DATE:
2/5/04

FIG. NO.

E1

DIRECT SHEAR TEST RESULTS

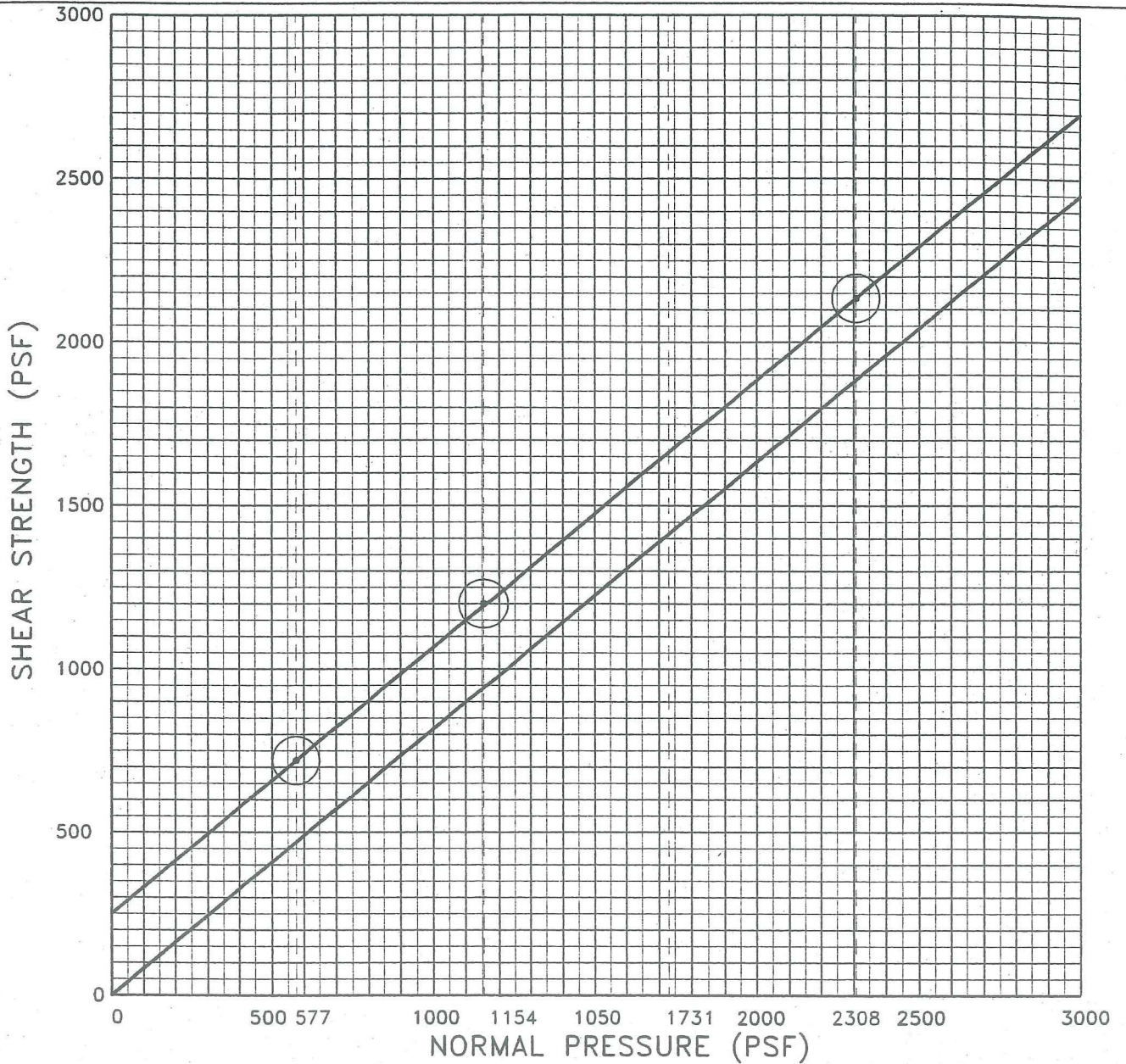

SYMBOL	SAMPLE LOCATION	COHESION (psf)	FRICTION ANGLE (°)	REMARKS
●	B1 @ 14.5' TO 15'	200	39	TERRACE DEPOSITS NATURAL FIELD SHEARS, SATURATED.
	NORMAL PRESSURE (psf)	SHEAR STRENGTH (psf)		
	577	.668		
	1154	1.156		
	2308	2.089		



ANTHONY-TAYLOR CONSULTANTS

San Diego (Corporate), 304 Enterprise Street, Escondido, CA 92029 (760) 738-8800

JOB NAME: LAS BRISAS

SITE ADDRESS: 135 SOUTH SIERRA AVE.
SOLANA BEACH, CA 92075

JOB NUMBER:
03-2283

REVIEWED BY:
DM/HE

DATE:
2/5/04

FIG. NO.

E2

W.O. 8157-A-SC
PLATE C-4

DIRECT SHEAR TEST RESULTS

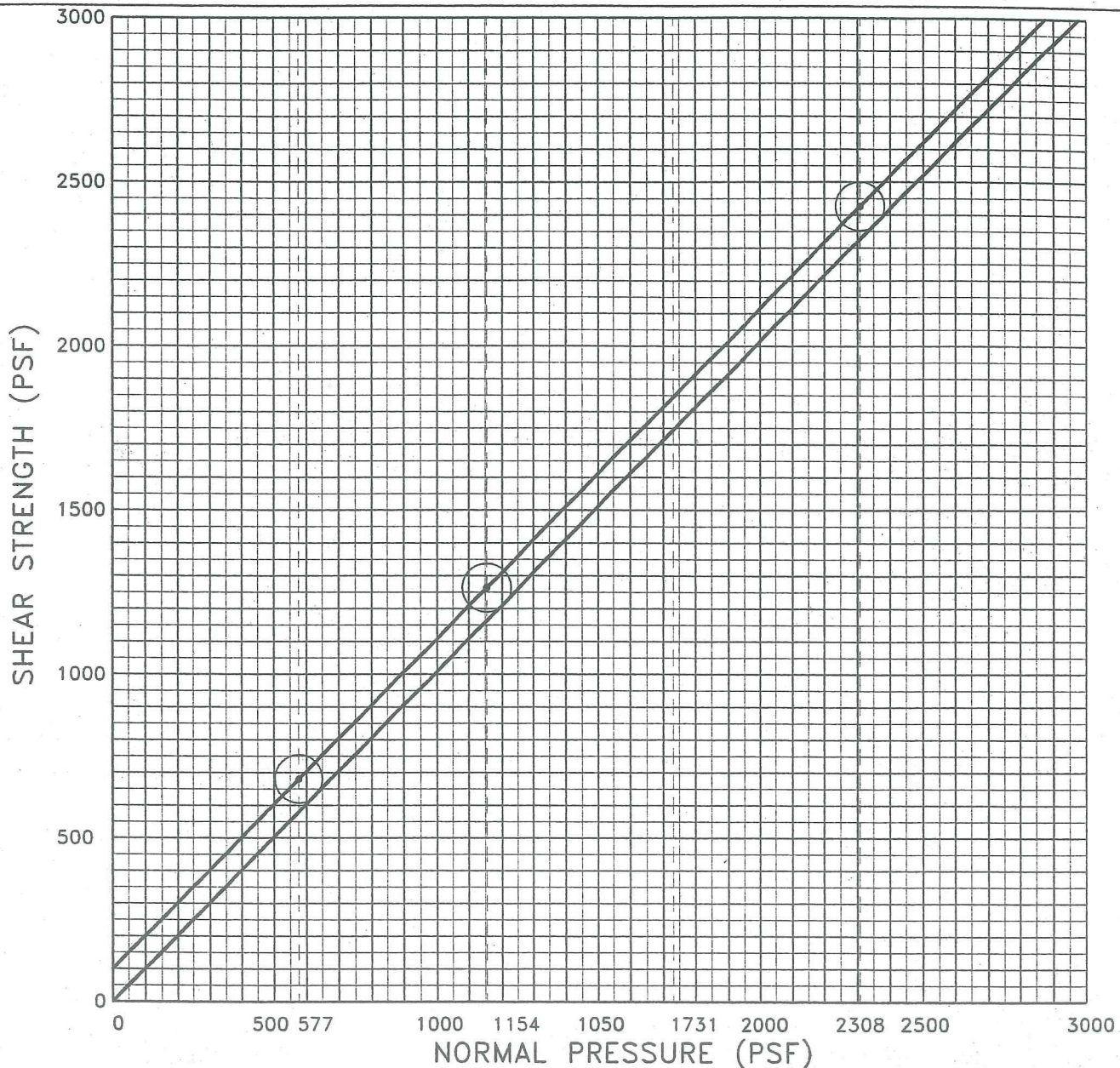

SYMBOL	SAMPLE LOCATION	COHESION (psf)	FRICTION ANGLE (°)	REMARKS
●	B1 @ 30' TO 30.5'	51	46	TERRACE DEPOSITS NATURAL FIELD SHEARS, SATURATED.
	NORMAL PRESSURE (psf)	SHEAR STRENGTH (psf)		
	577	668		
	1154	1.239		
	2308	2.473		



ANTHONY-TAYLOR CONSULTANTS

San Diego (Corporate), 304 Enterprise Street, Escondido, CA 92029 (760) 738-8800

JOB NAME: LAS BRISAS

SITE ADDRESS: 135 SOUTH SIERRA AVE.
SOLANA BEACH, CA 92075

JOB NUMBER:
03-2283

REVIEWED BY:
DM/HE

DATE:
2/5/04

FIG. NO.

E3

W.O. 8157-A-SC
PLATE C-5

DIRECT SHEAR TEST RESULTS

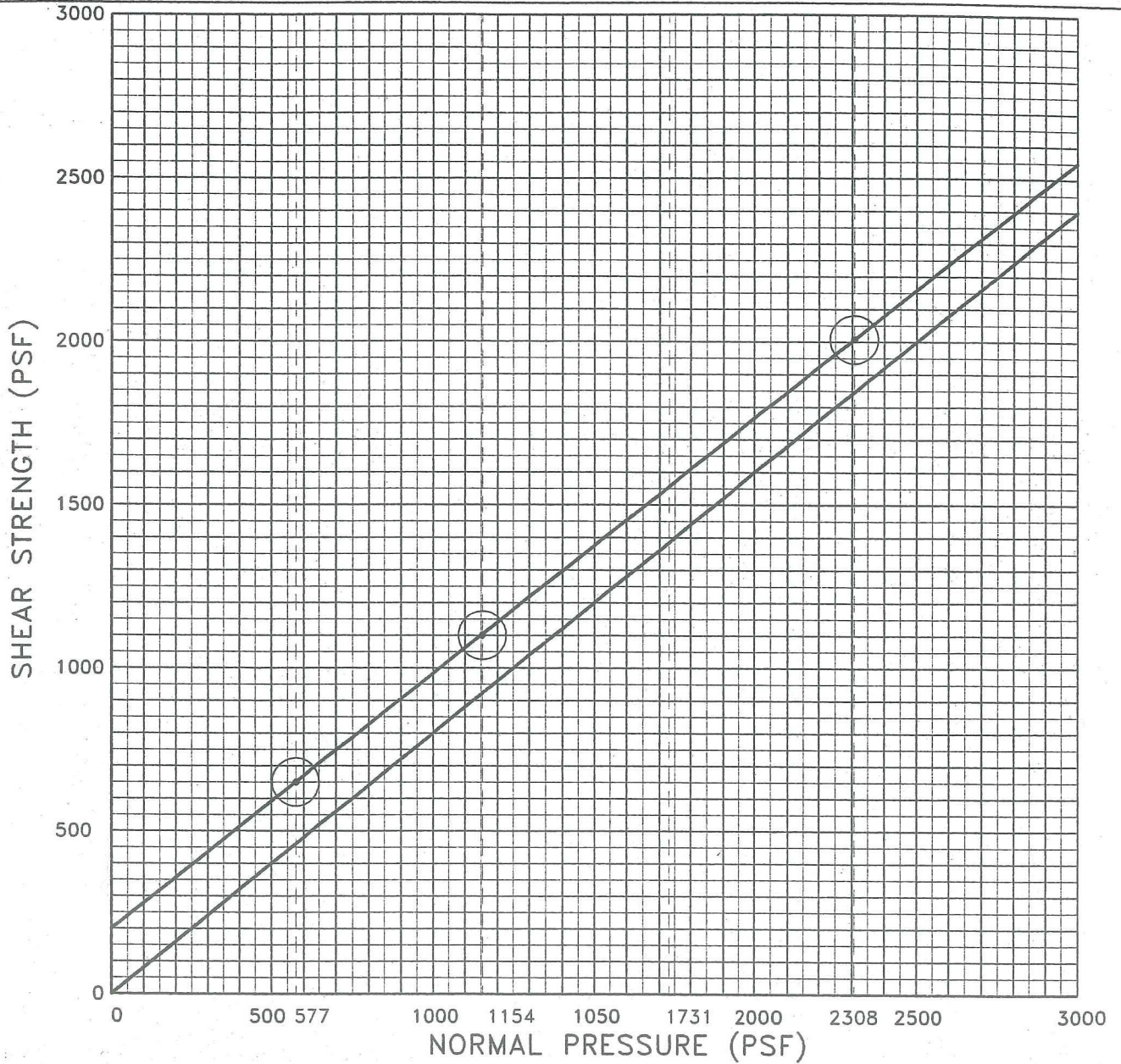

SYMBOL	SAMPLE LOCATION	COHESION (psf)	FRICTION ANGLE (°)	REMARKS
●	B-2 @ 16.0' TO 16.5'	175	39	TERRACE DEPOSITS NATURAL FIELD SHEARS, SATURATED.
	NORMAL PRESSURE (psf)	SHEAR STRENGTH (psf)		
	577	.616		
	1154	1.156		
	2308	2.038		



ANTHONY-TAYLOR CONSULTANTS

San Diego (Corporate), 304 Enterprise Street, Escondido, CA 92029 (760) 758-8800

JOB NAME: LAS BRISAS

SITE ADDRESS: 135 SOUTH SIERRA AVE.
SOLANA BEACH, CA 92075

JOB NUMBER:
03-2283

REVIEWED BY:
DM/HE

DATE:
2/5/04

FIG. NO.

E4

W.O. 8157-A-SC
PLATE C-6

DIRECT SHEAR TEST RESULTS

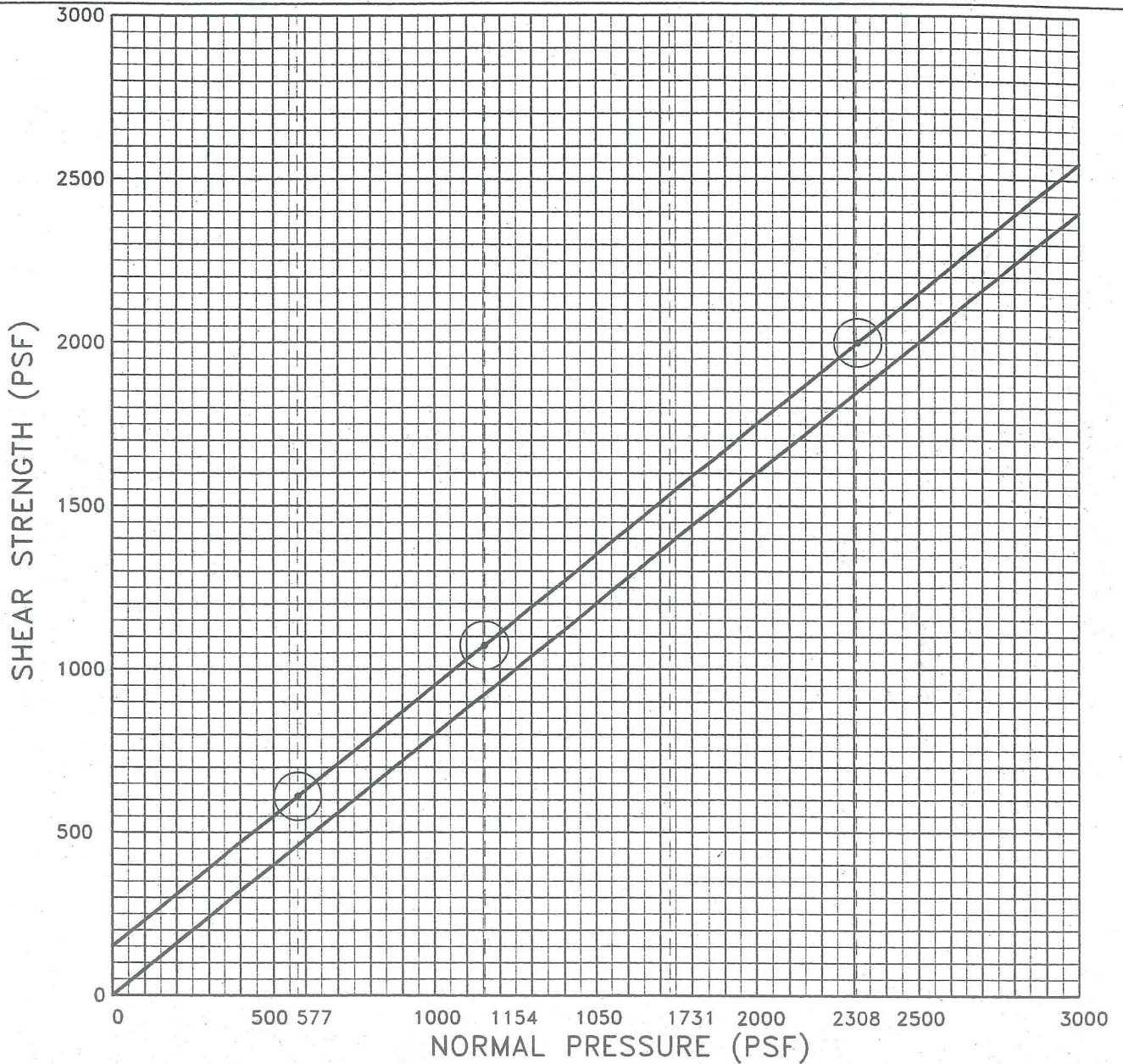

SYMBOL	SAMPLE LOCATION	COHESION (psf)	FRICTION ANGLE (°)	REMARKS
●	B-2 @ 48.5' TO 49'	150	39	TERRACE DEPOSITS NATURAL FIELD SHEARS, SATURATED.
	NORMAL PRESSURE (psf)	SHEAR STRENGTH (psf)		
	577	.637		
	1154	1.073		
	2308	2.048		



ANTHONY-TAYLOR CONSULTANTS

San Diego (Corporate), 304 Enterprise Street, Escondido, CA 92029 (760) 738-8800

JOB NAME: LAS BRISAS

SITE ADDRESS: 135 SOUTH SIERRA AVE.
SOLANA BEACH, CA 92075

JOB NUMBER: 03-2283

REVIEWED BY: DM/HE

DATE: 2/5/04

FIG. NO.

E5

W.O. 8157-A-SC
PLATE C-7

DIRECT SHEAR TEST RESULTS

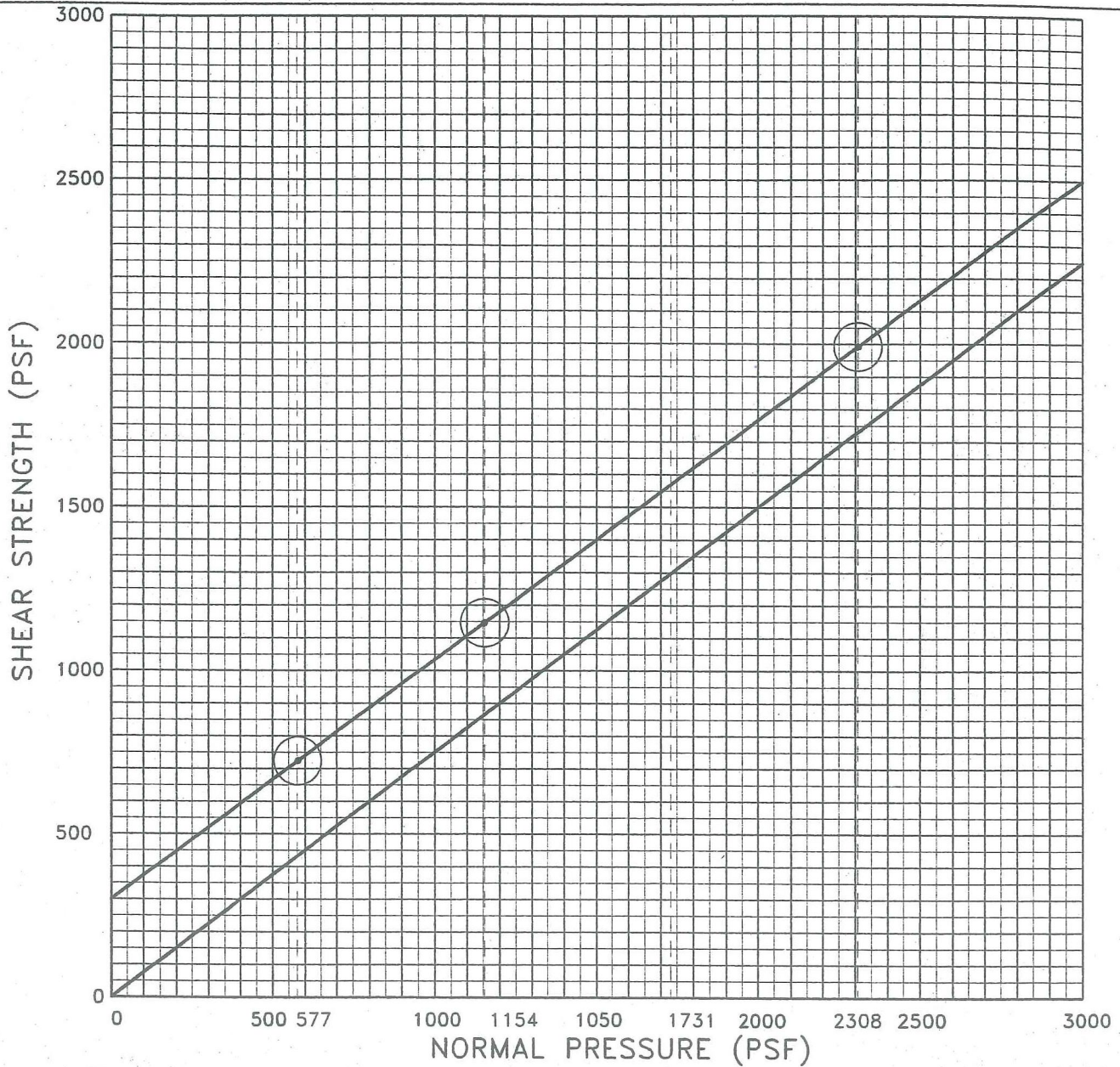

SYMBOL	SAMPLE LOCATION	COHESION (psf)	FRICTION ANGLE (°)	REMARKS
●	B-2 @ 56.0' TO 56.5'	290	37	TERRACE DEPOSITS NATURAL FIELD SHEARS, SATURATED.
	NORMAL PRESSURE (psf)	SHEAR STRENGTH (psf)		
	577	.772		
	1154	1.125		
	2308	2.089		



ANTHONY-TAYLOR CONSULTANTS

San Diego (Corporate), 304 Enterprise Street, Escondido, CA 92029 (760) 738-8800

JOB NAME: LAS BRISAS

SITE ADDRESS: 135 SOUTH SIERRA AVE.
SOLANA BEACH, CA 92075

JOB NUMBER: 03-2283

REVIEWED BY: DM/HE

DATE: 2/5/04

FIG. NO.

E6

W.O. 8157-A-SC
PLATE C-8

APPENDIX D

SLOPE STABILITY ANALYSIS

LAS BRISAS HOA / 8157-A-SC A-A' EXISTING STATIC

GEOSOILS, INC. - RBB

\\A-A' Existing Static.gsd

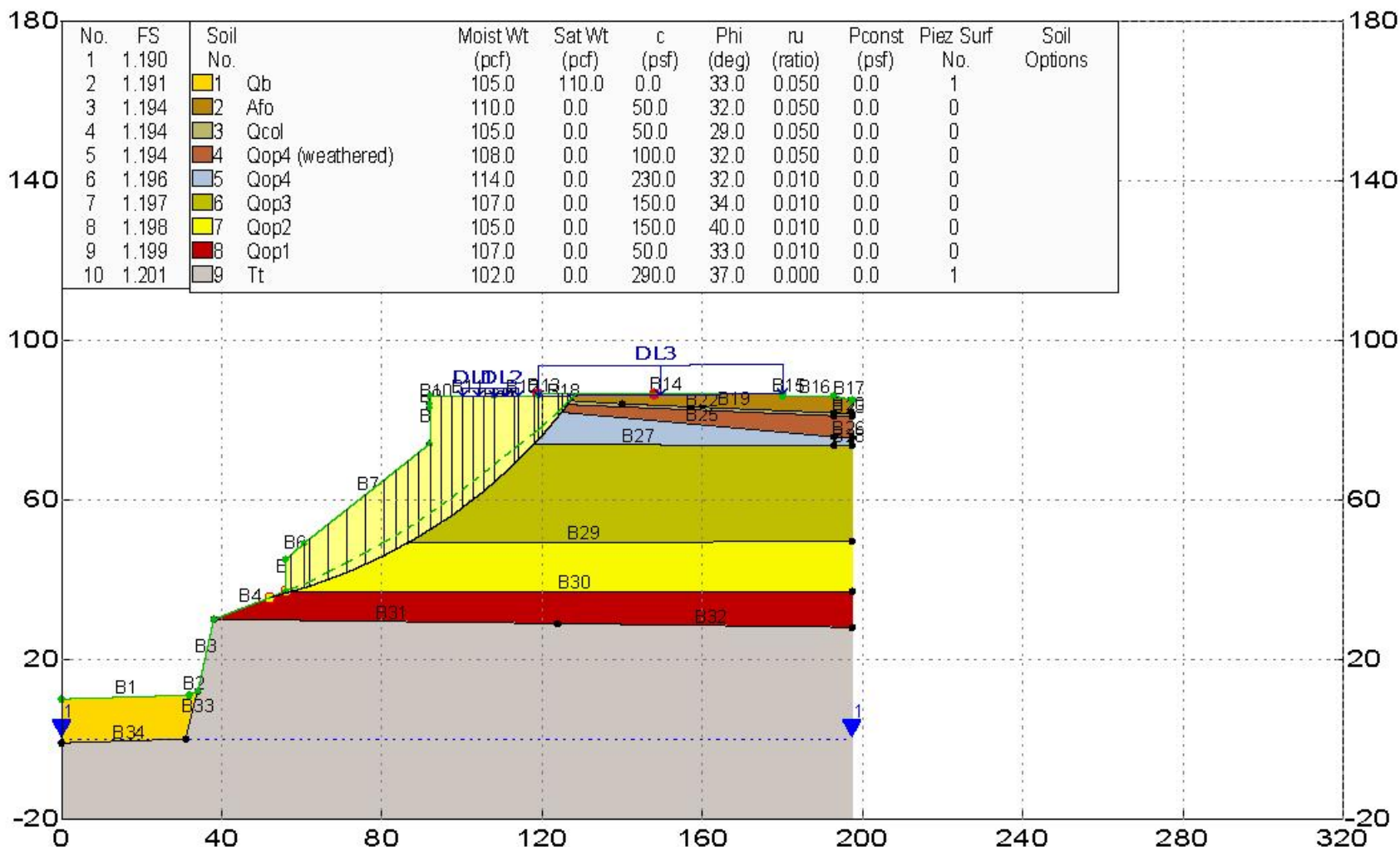

GEOSTASE FS = 1.190

Spencer Method

TOPOGRAPHIC SURVEY MAP -- LAS BRISAS -- 135 S SIERRA AVE

GS1 LEGEND

- Qb** — QUATERNARY BEACH DEPOSITS
- Afr** — ARTIFICIAL FILL (GEOGRID REINFORCED)
- Afw** — ARTIFICIAL FILL (SEAWALL)
- Afo** — ARTIFICIAL FILL - OLDER (FILL PLACED DURING THE ORIGINAL GRADING OF THE SUBJECT PROPERTY)
- Qop₄** — QUATERNARY OLD PARALIC DEPOSITS, SUBUNIT 4
- Qop₃** — QUATERNARY OLD PARALIC DEPOSITS, SUBUNIT 3
- Qop₂** — QUATERNARY OLD PARALIC DEPOSITS, SUBUNIT 2
- Qop₁** — QUATERNARY OLD PARALIC DEPOSITS, SUBUNIT 1
- Tt** — TERTIARY TORREY SANDSTONE
- APPROXIMATE LOCATION OF GEOLOGIC CONTACT, QUERIED WHERE UNCERTAIN
- APPROXIMATE LOCATION OF FAILURE LIMITS PER TCG, 2020
- APPROXIMATE LOCATION OF BLUFF EDGE
- BEDDING ATTITUDE WITH DIP IN DEGREES
- APPROXIMATE LOCATION OF EXPLORATORY BORING WITH TOTAL DEPTH IN FEET (GSI, THIS STUDY)
- APPROXIMATE LOCATION OF EXPLORATORY BORING WITH TOTAL DEPTH IN FEET (ATC, 2004)
- ESTIMATED POST-FAILURE ELEVATION CONTOURS (TCG, 2020)
- LOCATION OF GEOLOGIC CROSS SECTION
- N.A.P.** — NOT A PART OF THIS STUDY

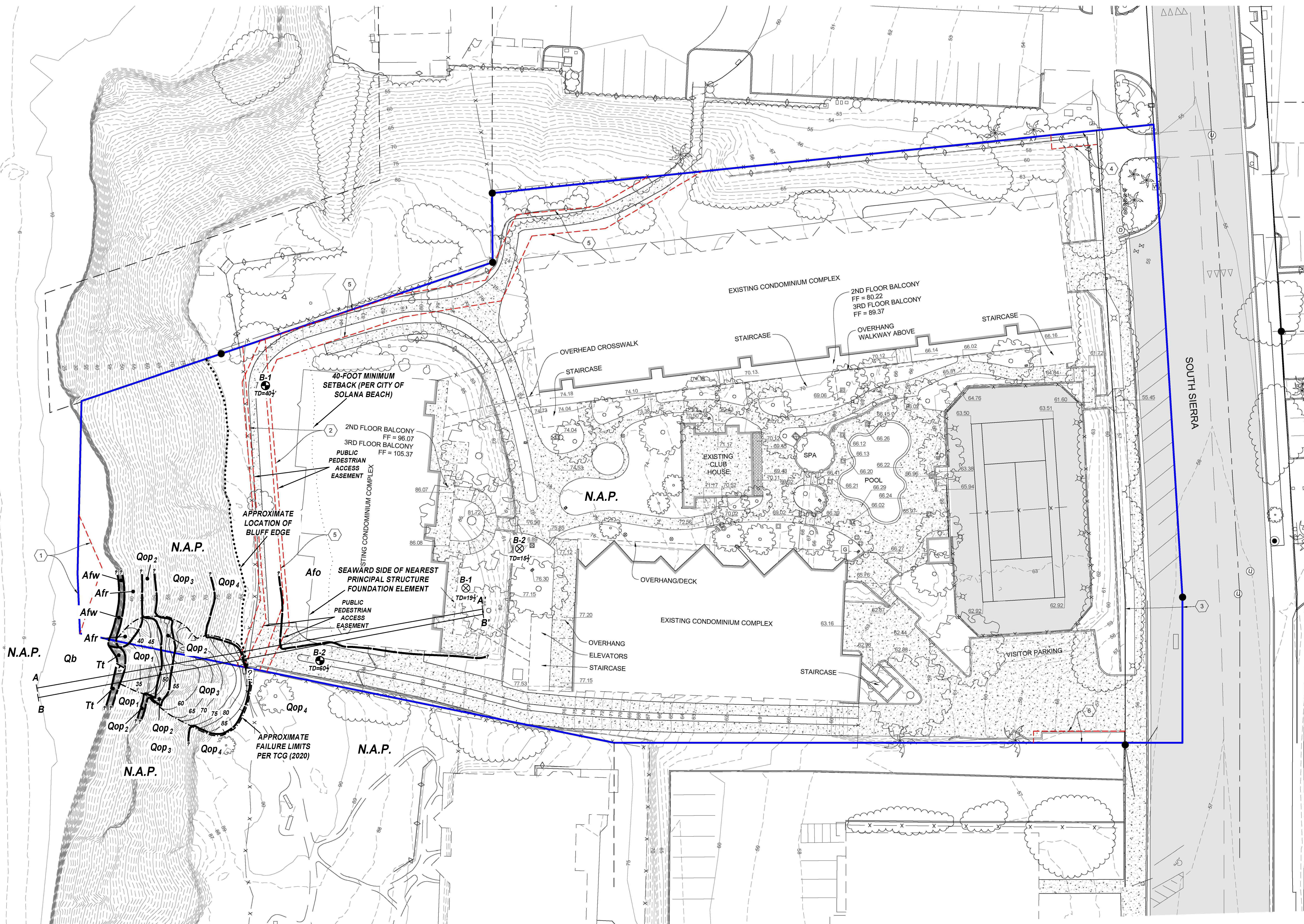

ALL LOCATIONS ARE APPROXIMATE
 This document or file is not a part of the Construction Documents and should not be relied upon as being an accurate depiction of design.



GEOTECHNICAL MAP

Plate 1

W.O. 8157-A-SC DATE: 10/21 SCALE: 1"=20'

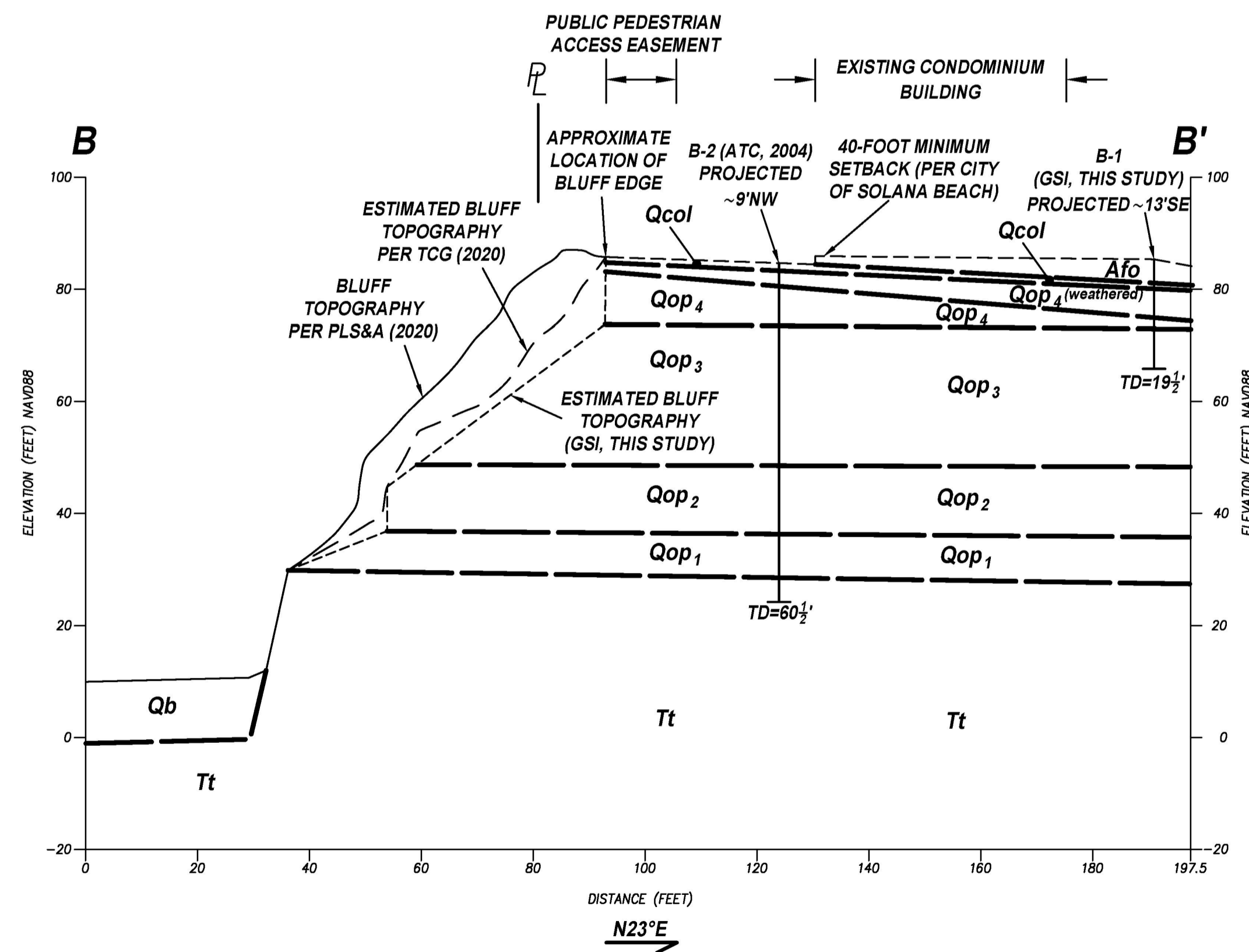
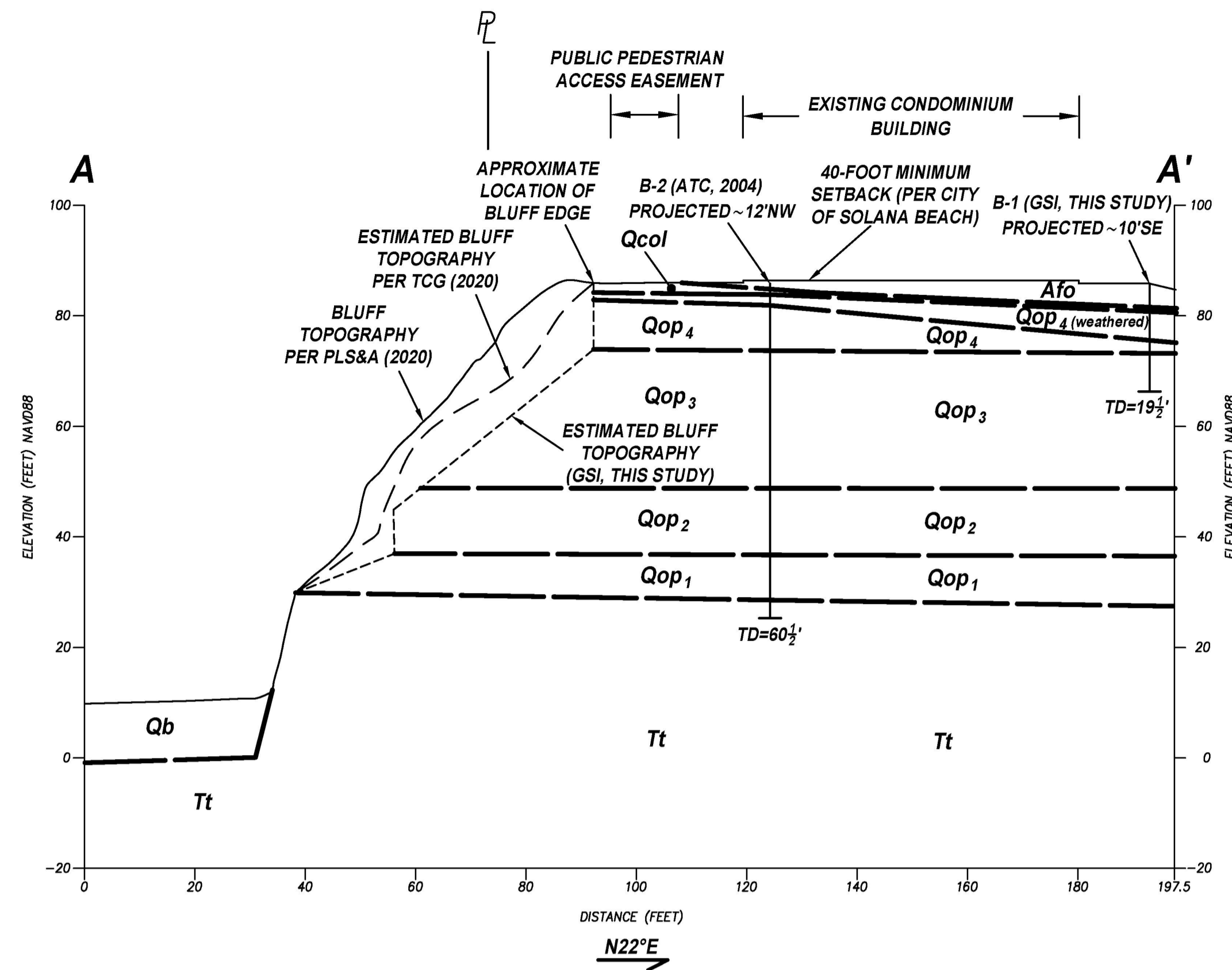

GSI LEGEND

- Qb** — QUATERNARY BEACH DEPOSITS
- Afo** — ARTIFICIAL FILL — OLDER (FILL PLACED DURING THE ORIGINAL GRADING OF THE SUBJECT PROPERTY)
- Qcol** — QUATERNARY COLLUVIUM
- Qop₄** — QUATERNARY OLD PARALIC DEPOSITS, SUBUNIT 4
- Qop₃** — QUATERNARY OLD PARALIC DEPOSITS, SUBUNIT 3
- Qop₂** — QUATERNARY OLD PARALIC DEPOSITS, SUBUNIT 2
- Qop₁** — QUATERNARY OLD PARALIC DEPOSITS, SUBUNIT 1
- Tt** — TERTIARY TORREY SANDSTONE
- — APPROXIMATE LOCATION OF GEOLOGIC CONTACT



**GEOLOGIC
CROSS SECTIONS A-A' & B-B'**
Plate 2

ALL LOCATIONS ARE APPROXIMATE
This document or file is not a part of the Construction Documents and should not be relied upon as being an accurate depiction of design.

W.O. 8157-A-SC DATE: 10/21 SCALE: 1"=20'

From: Bob Trettin <trettincompany@gmail.com>
Sent: Monday, February 7, 2022 8:42:38 AM
To: Corey Andrews <candrews@cosb.org>
Subject: Las Brisas Project

Hi Corey ... I wanted to make one clarification on the report: The opening paragraph states that "The shotcrete wall would be constructed with a drilled pier / caisson design with structural concrete between the piles."

The use of the terms "drilled piers" and "caissons" is usually associated with 18", 24" or larger diameter piers, and people hearing the term usually envision these larger piers which have been used in past rear-yard, upper bluff retention systems (i.e., 241 Neptune, among others).

The proposed Las Brisas project, as noted in the plans and geotech, will utilize a micropile system. Micropiles are steel bars (in this case approx. 2-inches in diameter) surrounded by neat grout (cement) for an overall diameter of approx. 6-inches. This should have a lower volume of cementitious material overall as opposed to conventional drilled shafts. And, it should provide a longer period of performance prior to requiring any additional shotcrete due to the closer spacing of the vertical elements. As we're working on an over-steepened, failing bluff, these are easier to place, less likely to cause additional disturbance as work is being done and less likely to have the smaller diameter drilled shafts cave-in during drilling. The overall shotcrete thickness will be approx. 8"-12" once sculpted.

I'm not sure if this distinction is critical ... but sometimes there are greater objections to the larger piers so I wanted to make sure you were clear on the materials.

Thanks, BOB

Bob Trettin, Principal
The Trettin Company
1195 La Moree Road, #18
San Marcos, CA 92078
Ph: (858) 603-1741
e-mail: trettincompany@gmail.com

From: Kristin Brinner <kristin@surfridersd.org>

Sent: Monday, February 7, 2022 5:04 PM

To: Angela Ivey <aivey@cosb.org>; Greg Wade <gwade@cosb.org>; Jewel Edson <jedson@cosb.org>; Kristi Becker <kbecker@cosb.org>; Kelly Harless <kharless@cosb.org>; David Zito <dzito@cosb.org>; Lesa Heebner <lheebner@cosb.org>

Cc: Jim Jaffee [REDACTED]; Stephanie Lee <stephanie@surfridersd.org>; Mitch Silverstein <mitch@surfridersd.org>

Subject: Re: Item B1. 135 S. Sierra Avenue CUP 17-17-27, Las Brisas HOA

And now with the attachment, my apologies.

On Mon, Feb 7, 2022 at 5:02 PM Kristin Brinner <kristin@surfridersd.org> wrote:

Honorable Mayor, Deputy Mayor and Councilmembers,

Please accept these comments on behalf of the San Diego Chapter of the Surfrider Foundation concerning Item B: Request for a Conditional Use Permit for the Construction of a Bluff Retention Device at 135 S. Sierra Avenue, Solana Beach. Case No: CUP 17-17-27; Applicant: Las Brisas Homeowners Association Resolution 2022-013.

If you have any questions I would be happy to discuss our comments ahead of Wednesday's city council meeting.

Sincerely,
Kristin

--

Kristin Brinner | Co-lead, Beach Preservation Committee | [Surfrider Foundation](https://www.surfrider.org/) she / her / hers
[REDACTED] | kristin@surfridersd.org



February 7, 2022

Delivered via email

To: Mayor Lesa Heebner
Deputy Mayor Kelly Harless
Councilmembers, Kristi Becker, Jewel Edson, David Zito,
Cc: City Manager Greg Wade
City of Solana Beach

Re: Item B1. Request for a Conditional Use Permit for the Construction of a Bluff Retention Device at 135 S. Sierra Avenue, Solana Beach. Case No: CUP 17-17-27; Applicant: Las Brisas Homeowners Association Resolution 2022-013.

Honorable Mayor, Deputy Mayor and Councilmembers,

The Surfrider Foundation is a nonprofit grassroots organization dedicated to the protection and enjoyment of our world's ocean, waves, and beaches through a powerful network. Thank you for the opportunity to comment on this project. In summary, mitigation fees must be assessed for this proposed mid and upper bluff retention device per the conditions of the permit for the original 2005 seawall at this location. We object to the staff report's recommendation that no sand mitigation or public recreation impact mitigation fees be charged for this proposed project. The staff report correctly sites numerous portions of the city's certified Land Use Plan (LUP) concerning mitigation fees:

Policy 4.39: Provide for reasonable and feasible mitigation for the impacts of all bluff retention devices which consists of the payment of Sand Mitigation Fees and Public Recreation Fees to the City or other assessing agency.

*Policy 4.49: Coastal structures shall be approved by the City only if all the following applicable findings can be made and the stated criteria satisfied...
(c) Mitigation for the impacts to shoreline and sand supply, public access and recreation and any other relevant coastal resource impacted by the coastal structure is required and shall be assessed in 20-year increments, starting with the building permit completion certification date.*

Policy 4.50: The bluff property owner shall pay for the cost of the coastal structure or Infill and pay a Sand Mitigation Fee and a Public Recreation Fee per LUP Policy 4.39

Despite these policies, the staff report incorrectly states that no mitigation fees are required:

"As a condition of their 2005 Coastal Development Permit (CDP) to construct the existing seawall below the Las Brisas Condominiums, the Applicant was required to pay a fee of \$309,000 for, "the loss of sandy beach area and thus the loss of public recreational impacts" as well as "\$22,977.36 for the loss of sand." The proposed lateral return wall would be constructed to retain the beach sands behind the existing seawall for which mitigation fees were already paid, therefore, no additional mitigation fees are required with this permit." (page 9 of 11 of staff report)

Given that the staff report discusses one condition of Coastal Development Permit (CDP) 6-05-72¹, it is surprising that the staff report then ignores the specifics of Special Condition 2 of this permit which was granted in 2005 to construct the original seawall:

*"Mitigation for Impacts to Public Recreational Use and Sand Supply...The required in-lieu fee mitigation covers impacts only through the identified 22-year design life of the seawall. No later than 21 years after the issuance of this permit, the permittees or their successor in interest shall apply for and obtain an amendment to this permit that either requires the removal of the seawall within its initial design life or requires mitigation for the effects of the seawall on shoreline sand supply, and thus public recreational use, for the expected life of the seawall beyond the initial 22 year design life. **If within the initial design life of the seawall the permittees or their successor in interest obtain a coastal development permit or an amendment to this permit to enlarge or reconstruct the seawall or perform repair work that extends the expected life of the seawall, the permittee shall provide mitigation for the effects of the additional size of the seawall or the extended effects of the existing seawall on shoreline sand supply and public recreational use for the expected life of the seawall beyond the initial 22 year design life.**" (emphasis added)*

The TerraCosta geotechnical report submitted by the applicants states that this new bluff retention device is required to protect the 2005 seawall:

"...it is our recommendation that Las Brisas initiate the required permitting

¹ <https://documents.coastal.ca.gov/reports/2005/10/W8e-10-2005.pdf>

*actions to construct a caisson/grade beam/tieback lateral wall that would extend from the southern terminus of the existing permitted seawall to the top-of-bluff. The engineering design we are submitting for your review would be sufficient to return a minimum 1.5 factor of safety to the threatened public access areas and to the existing residential structure on the Las Brisas property. **Further, it will protect the existing, permitted lower coastal bluff seawall from being flanked** and will prevent further loss of the mid to upper coastal bluff at Las Brisas.” (page 2, TerraCosta Coastal Bluff Evaluation/Project Recommendations, page 101 of agenda packet, emphasis added)*

Special condition 2 of the 2005 CDP should therefore be enforced here: the 2005 seawall is essentially being enlarged and its expected life is being extended by the proposed protection device. We respectfully request that per the 2005 CPD 6-05-72, new mitigation fees be calculated and collected as a condition of granting this new permit.

Sincerely,

Kristin Brinner & Jim Jaffee
Residents of Solana Beach
Co-Leads of the Beach Preservation Committee
San Diego County Chapter, Surfrider Foundation

From: gosurfsong@cox.net <gosurfsong@cox.net>

Sent: Tuesday, February 8, 2022 6:15 AM

To: Lesa Heebner <lheebner@cosb.org>; Kristi Becker <kbecker@cosb.org>

Cc: Mo Sammak <msammak@cosb.org>; Joseph Lim <jlim@cosb.org>; Angela Ivey <aivey@cosb.org>; Greg Wade <gwade@cosb.org>

Subject: Recommending Approval of Las Brisas Bluff Retention Device CUP 17-17-27

The Surfsong HOA letter strongly encouraging our City Council to approve the Las Brisas bluff retention device conditional use permit application at the February 9th City Council Meeting is attached.

Thank you for your support and your service to our great community.

John Steel
858-254-5418



February 7, 2022

Mayor Lesa Heebner & City Council

City Council Meeting: Wednesday, February 9, 2022
Las Brisas HOA Public Hearing
Conditional Use Permit for a Bluff Retention Device
Case No: CUP 17-17-27
Las Brisas HOA
135 S. Sierra Avenue, Solana Beach

Dear Mayor and City Council:

Surfsong HOA strongly recommends City Council approval of the Conditional Use Permit (CUP 17-17-24) for a Bluff Retention Device proposed by Las Brisas HOA.

- Surfsong HOA is the most adjacent, and potentially most impacted neighbor, to the south of Las Brisas HOA. We share an east/west property line.
- Surfsong HOA has committed the use of our adjacent property for equipment staging to facilitate the construction of the Las Brisas BRD.
- Las Brisas owners will be served by your favorable BRD decision.

Thank you for the opportunity to share our strong support for this Conditional Use Permit and the Las Brisas Bluff Retention Device.

John Steel
Board President
Surfsong HOA Board of Directors

Surfsong Owners Association, c/o J. D. Richardson Co. Inc.
3130 Fourth Avenue, San Diego, CA 92103
Tel: 619-234-9884 \ Fax: 619-234-9570

The Trettin Company
Community & Government Relations / Project Development

February 9, 2022

TO: Honorable Mayor and Councilmembers
City of Solana Beach

FROM: Bob Trettin, representing
Las Brisas Condominium Association

RE: Response to Surfrider Foundation Letter, dated February 7, 2022

The Surfrider Foundation has submitted a letter which stipulates that the lateral wall proposed by Las Brisas at the southern terminus of the existing, permitted seawall will protect and thereby extend the life of the seawall. Therefore, Surfriders argues that additional mitigation should be assessed to the proposed project.

Surfriders, however, has erred in their interpretation of Special Condition #2, which they cited as justification for additional mitigation. Earlier in that same Special Condition it is clearly cited that *"No later than 21 years after issuance of this permit, the permittees or their successors in interest shall apply for and obtain an amendment to this permit that either requires the removal of the seawall within its initial design life or requires mitigation for the effects of the seawall on shoreline sand supply, and this public recreational use, for the expected life of the seawall beyond the initial 22 year design life."*

The key understanding in this language is that the Las Brisas Association is required to initiate an amendment in 2026, to become effective in 2027, to provide mitigation for a period of time extending from 2027 to 2047 (as the Commission now works on 20-year mitigation intervals). Since mitigation for the seawall has been provided through 2027, and Las Brisas is required to pay additional mitigation if the wall is to remain beyond that date, the issue of whether the lateral wall protects the southern areas of the seawall / tiebacks and thereby is extending its life is irrelevant.

The Coastal staff and Coastal Commission made that clear back in 2010 when a significant failure of the lower coastal bluff to the immediate south of the Las Brisas seawall failed and a Coastal Development Permit Amendment was approved for an initial extension of the lateral return wall at this location.

The Commission staff provided the following recommendation on sand mitigation in this excerpt from the 2010 staff report on that project (CDP 6-05-072A1):

"The Commission's staff engineer has determined that the proposed return wall extension will create no new impacts that would require additional sand supply mitigation. The approval of the existing 120 foot Las Brisas seawall included mitigation for the loss of sand from the bluffs behind the seawall. The proposed return wall will similarly prevent this same sand from entering the littoral system. Thus, because mitigation for this loss of sand was included in the permit for the original seawall, no additional mitigation is needed here. The proposed return wall extension will be constructed behind the current return wall (perpendicular to the shore) in an area that, previous to the significant failure of the lower coastal bluff which occurred on January 16, 2010, was coastal bluff. Therefore, no public beach area will be impacted as a result of the return wall extension. Thus, as conditioned, the Commission finds the project consistent with the public access and recreation policies of the Coastal Act."

In the same report, Commission staff made a similar recommendation relating to public access / recreation mitigation:

"The Commission's staff engineer has determined that the proposed return wall extension will create no new impacts that would require additional access/recreation mitigation. The proposed return wall extension will be constructed behind the current return wall (perpendicular to the shore) in an area that, previous to the significant failure of the lower coastal bluff which occurred on January 16, 2010, was coastal bluff. The proposed return wall provides shoreline protection for the same area of bluff (the same sand and other materials) that are kept in place within the bluff by the existing seawall. The Commission required mitigation for the public access and recreation impacts of the existing seawall; thus, because the proposed return wall provides protection for the same bluff area addressed in the permit for the original seawall, there is no additional impact caused by the return wall that would require additional mitigation. No public beach area will be impacted as a result of the return wall extension. Thus, as conditioned, the Commission finds the project consistent with the public access and recreation policies of the Coastal Act."

The Commission fully concurred with both of the above staff recommendations and no additional or extended mitigation was required for the Coastal Development Permit Amendment. The nexus for duplicative mitigation charges clearly did not exist then ... and does not exist with the current project proposal.

In summary, the Surfrider Foundation can be assured that additional mitigation for extending the presence of the seawall beyond 2027 is required by the existing seawall permit and will occur.

Respectfully submitted,



BOB TRETTIN, Principal
The Trettin Company

1195 La Moree Road, #18
Ph: (858) 603-1741

San Marcos, California 92078
e-mail: trettincompany@gmail.com

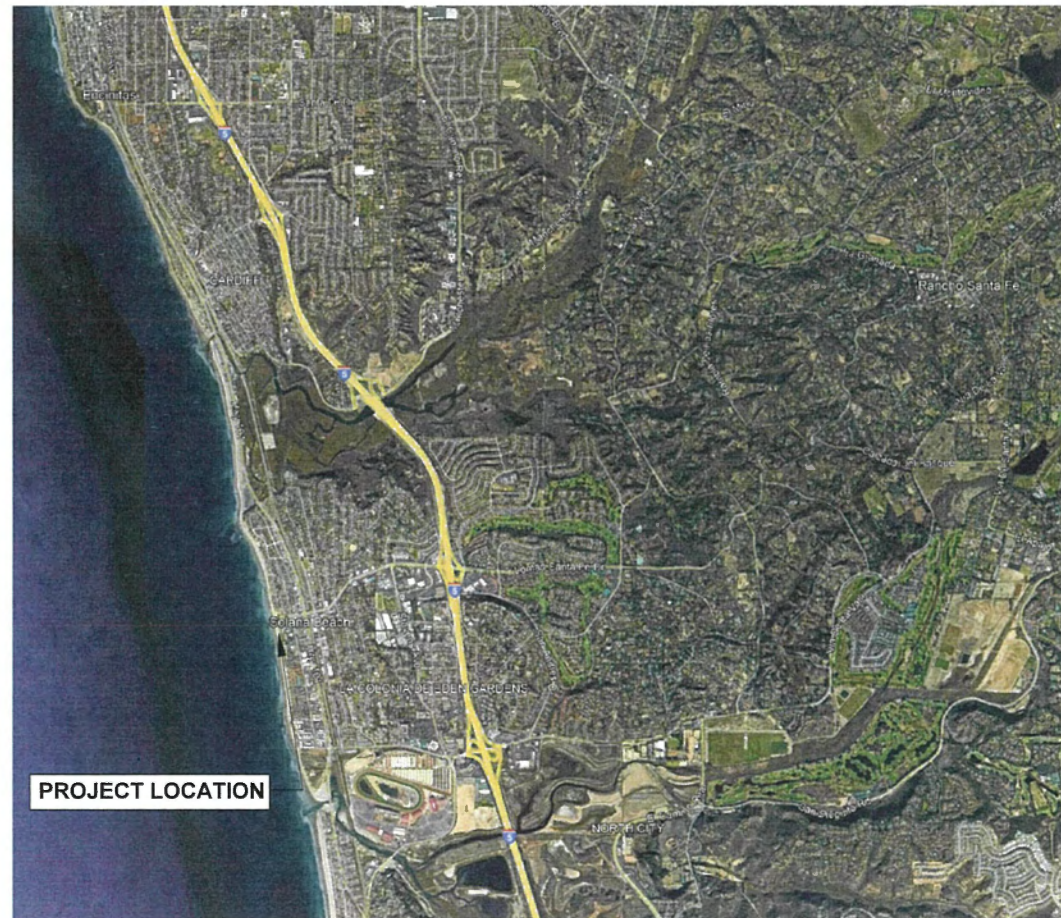

Contract Drawings For
**Las Brisas
Condominiums**
Bluff Stabilization
Civil/Geotechnical

Project No.
APS230095

City of Solana Beach, California
December 2023

INDEX OF DRAWINGS

C-01	COVER
C-02	GENERAL NOTES
C-03	GENERAL NOTES (2)
C-04	EXISTING SITE & ACCESS PLAN
C-05	PROJECT SITE PLAN
C-06	SECTION VIEW - CUTOFF WALL MICROPILE LAYOUT
C-07	SECTION VIEW - PILE CAP AND DRAINAGE
C-08	CUTOFF WALL DETAILS
C-09	MICROPILE ANCHOR DETAILS
C-10	MICROPILE CAP DETAILS
C-11	SECTION VIEW - RSS SYSTEM
C-12	PHASE II MITIGATION SECTION
C-13	MICROPILE TESTING DETAILS

GENERAL:

- THORCON (CONTRACTOR) WILL BE LEAD FOR THE JOB SITE CONDITIONS AND SAFETY DURING CONSTRUCTION HOURS. JOB SITE WILL BE KEPT REASONABLY SECURE TO DETER UNAUTHORIZED ENTRY OR TAMPERING. HOWEVER, THOSE WHO ENTER THE CONSTRUCTION ZONE WITHOUT AUTHORIZATION WILL BE CONSIDERED TRESPASSING.
- CONTRACTOR WILL USE UTILITY ONE CALL SERVICES, REQUEST UTILITY MAPS, AND REQUEST POTHOLING AS NEEDED TO LOCATE, AND MARK KNOWN UTILITIES.
DIG ALERT: DIAL 811, OR DIGALERT.ORG
CITY OF SOLANA BEACH PUBLIC WORKS: (858) 720-2470
- AT THE END OF EACH WORKDAY CONTRACTOR WILL LEAVE THE WORK AREA FREE OF HAZARDS AND PROVIDE TEMPORARY SIGNS, WARNING DEVICES, AND/OR BARRICADES, AS NEEDED.
- CONTRACTOR WILL KEEP RECORDS OF DRILLING CONDITIONS, GROUT MIX SPECIFICATIONS, AND OTHER NOTES ON THESE PLANS AS NEEDED TO PROVIDE AS-BUILT INFORMATION TO THE OWNER AFTER PROJECT COMPLETION.
- CONTRACTOR UNDERSTANDS WORKING HOURS FOR THIS SITE TO BE 7:00 AM TO 7:00 PM EACH DAY, MONDAY THROUGH FRIDAY.
- CONTRACTOR WILL NOTIFY THE CITY OF SOLANA BEACH AT (858) 720-2470, AT LEAST 24 HOURS BEFORE THE FIRST DAY OF THE PROJECT.

STANDARD REQUIREMENTS:

CONTRACTOR WILL PERFORM THE WORK IN GENERAL ACCORDANCE WITH THE LATEST EDITION AND SUPPLEMENTS OF THE "STANDARD SPECIFICATIONS FOR PUBLIC WORKS CONSTRUCTION" SAN DIEGO REGIONAL STANDARD DRAWINGS AND CITY OF SOLANA BEACH ENGINEERING CONSTRUCTION STANDARDS

ASSESSOR PARCEL NUMBERS: 298-010-54-0001
ADDRESSES: 135 S. SIERRA AVE.

EROSION CONTROL NOTES:

- CONTRACTOR WILL PLACE SILT FENCE AT THE TOE OF THE SLOPE (TOP OF SEA WALL) TO LIMIT ERODED MATERIAL FROM REACHING THE PUBLIC BEACH.
- CONTRACTOR WILL USE DIKES, BERMS, OR TRENCHES TO LIMIT STORMWATER FLOWING OVER CRESTS OF THE SLOPE.
- CONTRACTOR WILL USE WATER AS NEEDED TO MINIMIZE AIR BORNE DUST ON SITE.

HOUSE KEEPING:

- THE SITE WILL BE ORGANIZED AND CLEAR OF ANY TRASH OR DEBRIS. ALL TRASH WILL BE PLACED IN PROPER CONTAINER(S) AND REMOVED WHEN NECESSARY.

HOUSE KEEPING:

- THE SITE WILL BE ORGANIZED AND CLEAR OF ANY TRASH OR DEBRIS. ALL TRASH WILL BE PLACED IN PROPER CONTAINER(S) AND REMOVED WHEN NECESSARY.

SAFETY:

- ALL SAFETY PLANS FOR LIFTING, HEARING, DUST CONTROL, PPE, ETC., WILL BE IN PLACE AND FOLLOWED. PPE INCLUDES SAFETY VEST, STEEL TOED SHOES, HARD HAD, SAFETY GLASSES, RESPIRATOR DURING DUST PRODUCING ACTIVITIES, AND GLOVES.
- CONTRACTOR WILL GENERATE A SITE-SPECIFIC HEALTH AND SAFETY PLAN THAT MUST BE REVIEWED AND SIGNED BY ALL EMPLOYEES, SUBCONTRACTORS, AND VISITORS TO THE SITE.
- CONTRACTOR WILL CONDUCT A DAILY SAFETY MEETING TO REVIEW JOB HAZARD ANALYSIS FOR EACH DAYS ANTICIPATED TASKS.

EMPLOYEE CERTIFICATIONS

- ACI SHOTCRETE NOZZLEMAN CERTIFICATION
- 10-HOUR OCCUPATIONAL SAFETY AND HEALTH TRAINING COURSE IN CONSTRUCTION SAFETY AND HEALTH
- AMERICAN RED CROSS STANDARD FIRST AID TRAINING.

ANTICIPATED CONSTRUCTION SEQUENCE WORK SCHEDULE

1. DELINEATE LIMITS OF STABILIZATION. NOTIFY LOCAL UTILITY PROVIDERS TO LOCATE AND MARK POTENTIAL UNDERGROUND UTILITIES. DAYLIGHT UTILITIES IN POTENTIAL CONFLICT, AS NECESSARY.
2. PREPARE THE WORK AREA FOR MICROPILE INSTALLATION AND CUTOFF WALL CONSTRUCTION:
 - a. INSTALL EROSION CONTROL FENCE AT THE TOP OF EXISTING DURING CONSTRUCTION.
 - b. MINOR RE-SHAPING OF EXISTING SCARP AND SURROUNDING GRADES MAY BE NECESSARY TO FACILITATE CONSTRUCTION OF THE MICROPILE CUTOFF WALL.
 - c. MARK THE LOCATIONS OF THE PROPOSED STABILIZATION ELEMENTS WITH SURVEY MARKING PAINT OR OTHER SIMILAR.
3. INSTALL MICROPILE ELEMENTS. EACH ELEMENT WILL BE GROUTED DURING DRILLING UNLESS DIRECTED OTHERWISE BY ENGINEER.
4. CONSTRUCT THE CUTOFF WALL:
 - a. PLACE REINFORCING STEEL AND DRAIN STRIPES PER THESE DRAWINGS.
 - b. USE WOOD OR SIMILAR FORMWORK ON THE NORTH SIDE OF THE CUTOFF WALL TO FACILITATE SHOTCRETE PLACEMENT.
 - c. PLACE SHOTCRETE FROM THE BOTTOM UP TO THE REQUIRED THICKNESS DETAILED IN THESE PLANS.
5. PREPARE AREA NORTH OF THE CUTOFF WALL FOR REINFORCED SOIL SLOPE (RSS) SYSTEM INSTALLATION. MINOR GRUBBING AND GRADING MAY BE NECESSARY.
6. INSTALL REINFORCED SOIL SLOPE (RSS) IN LIFTS AS DETAILED IN THESE DRAWINGS AND PER THE MANUFACTURER INSTALLATION PROCEDURES.
7. SITE CLEANUP AND DEMOBILIZATION FROM SITE.
 - a. CONCRETE, GROUT, AND OTHER CONSTRUCTION DEBRIS WILL BE REMOVED PERIODICALLY THROUGHOUT THE WORK.
- FINAL CLEANUP OF THE SITE TO INCLUDE REASONABLE HAND CLEANING METHODS LIKE SWEEPING, SPRAYING WITH WATER, AND REMOVAL OF TRASH AND DEBRIS. MAJOR LANDSCAPING SHOULD NOT BE NEEDED IF PROPER ACCESS IS GRANTED THROUGHOUT THE PROJECT.

SIZE AND TYPE OF STABILIZATION ELEMENTS:

- THE MICROPILE ELEMENTS SHALL CONSIST OF MINIMUM 51 MM NOMINAL DIAMETER, SELF-DRILLING HOLLOW BAR WITH A MINIMUM YIELD STRENGTH OF 152 KIPS (677 kN). SACRIFICIAL DRILL BITS WILL BE ATTACHED TO THE STABILIZATION ELEMENTS PRIOR TO INSTALLATION.
- SACRIFICIAL DRILL BITS ARE NOT PERMANENTLY INCORPORATED INTO THE PROJECT AND MAY BE REMOVED AFTER DRILLING OR LEFT AT THE PROJECT FOR THE CONTRACTOR'S CONVENIENCE. SACRIFICIAL DRILL BITS ARE NOT END PRODUCTS. SACRIFICIAL BITS MAY NOT BE PRODUCED IN THE UNITED STATES.
- ENGINEER MAY ELECT TO MODIFY TYPE OF STABILIZATION ELEMENTS, LENGTH, OR INSTALLATION METHOD, DEPENDING ON ACTUAL DRILLING CONDITIONS.

FACING AND DRAINAGE SYSTEM:

- DRAIN STRIPS WILL BE PROVIDED AND INSTALLED APPROXIMATELY EVERY SIX FEET ALONG THE NORTH SIDE OF THE CUTOFF WALL. THE DRAIN STRIPS SHALL BE PLACED WITH THE GEOTEXTILE SIDE AGAINST THE FORMWORK.
- DRAIN STRIPS WILL BE CONTINUOUS AND ANY SPICES SHALL BE MADE WITH A ONE-FOOT MINIMUM OVERLAP SUCH THAT THE FLOW OF WATER IS NOT IMPEDED.
- DRAIN STRIPS SHALL EXTEND BEYOND THE FACE OF THE SHOTCRETE AT THE DOWNHILL FACE.
- DRAIN STRIPS SHALL BE MINIMUM 12" WIDE.

REINFORCING STEEL PLACEMENT:

- REINFORCING STEEL FOR THIS PROJECT SHALL BE EPOXY COATED OR GALVANIZED.
- WELDED WIRE MESH (WWM) WILL BE PLACED ON BOTH SIDES OF THE EXTENDED MICROPILES AS SHOWN IN THESE DRAWINGS.
- MINIMUM NO. 5 REBAR WILL BE TIED TO THE SOUTH-SIDE OF WIRE MESH. FOLLOW SPACING AND SPLICE LENGTHS AS SHOWN IN THESE DRAWINGS.
- MINIMUM NO. 5 REBAR WILL ALSO BE USED FOR THE MICROPILE CAP. FOLLOW SPACING AND SPLICE LENGTHS AS SHOWN IN THESE DRAWINGS.

MICROPILE CAP PLATES:

- STEEL BEARING PLATES (6"x6"x1/2", OR APPROVED OTHER) WILL BE PLACED OVER THE MICROPILES IN THE MICROPILE CAP AND ATTACHED WITH A HEX NUT ON TOP AND BOTTOM. IF MICROPILES EXTEND BEYOND THE TOP HEX NUT, THEY WILL BE TRIMMED.

REINFORCED SOIL SLOPE (RSS) SYSTEM:

- HIGH PERFORMANCE TURF REINFORCEMENT MAT (HPTRM) OR APPROVED OTHER.
- MATERIAL IS THREE-DIMENSIONAL, LOFTY WOVEN POLYPROPYLENE HPTRM.
- MATRIX COMPOSED OF TRILOBAL MONOFILAMENT YARNS WOVEN INTO UNIFORM CONFIGURATION OF RESILIENT PYRAMID-LIKE PROJECTIONS THAT MINIMIZE WATERING REQUIREMENTS WHILE ENHANCING VEGETATION ESTABLISHMENT.
- MUST BE A HOMOGENEOUS MATRIX, AND NOT COMPRISED OF LAYERS, COMPOSITES, OR DISCONTINUOUS MATERIALS, OR OTHERWISE LOOSELY HELD TOGETHER BY STITCHED OR GLUED NETTING.
- THE HPTRM SHOULD BE THE FOLLOWING VALUES.

PROPERTY:	UNITS:	UNITS:	MINIMUM REQUIREMENT:
THICKNESS	ASTM D6525	IN	0.4
LIGHT PENETRATION	ASTM D6567	%	10
TENSILE STRENGTH	ASTM D6818	LB/FT	4000 X 3000
TENSILE ELONGATION	ASTM 6818	%	40 X 35
RESILIENCY	ASTM 6524	%	80
FLEXIBILITY	ASTM 6575	IN-LB	0.534
UV RESISTANCE	ASTM 4355	%	90 AT 6000 hrs

- WOOD OR PLASTIC STAKES, OR STEEL PINS ARE USED TO PIN-DOWN THE GEOTEXTILE NEAR THE BACK OF THE REINFORCEMENT ZONE TO HOLD THE GEOTEXTILE TAUT WHILE ALIGNING THE WALL FACE AND PLACING SOIL BACKFILL. THESE ARE INSTALLED AS NEEDED ALONG THE HPTRM BUT AT A FREQUENCY NO LESS THAN 1 PER 6 LINEAL FEET. THE STAKES OR PINS SHALL BE 9 TO 12-INCHES LONG.
- BACKFILL WILL COMPRISE OF GENERAL FILL WITH A UNIFIED SOIL CLASSIFICATION SYSTEM DESIGNATION OF A SILTY SAND (SM) OR APPROVED BY ENGINEER.
- THE SM MATERIAL WILL CONSIST OF INERT EARTH MATERIALS WITH LESS THAN 3% ORGANICS OR OTHER DELETERIOUS SUBSTANCES, AND LESS THAN 5% FINES.
- FILL WILL BE PLACED IN UNIFORM, MAXIMUM 12-INCH LIFTS.
- FILL IN THE UPPER 12-INCHES OF THE GRADED SLOPE FACE WILL NOT BE COMPACTED DUE TO THE LACK OF CONFINEMENT.
- FILL BEHIND THE UPPER 12-INCHES OF THE GRADED SLOPE FACE WILL BE COMPACTED TO AT LEAST 90% OF THE MATERIALS MAXIMUM DRY DENSITY AND BE UNIFORMLY MOISTURE CONDITIONED TO AT LEAST THE OPTIMUM MOISTURE CONTENT AS DETERMINED BY ASTM D 1557.

RSS ANCHOR DETAILS:

TYPE B3 ANCHOR PROPERTES

COMPONENT MATERIALS:	MATERIAL COMPOSITION:	PHYSICAL PROPERTIES:	
ANCHOR HEAD	HOT DIP GALVANIZED DUCTILE IRON	6.43 IN x 1.84 IN x 2.36 IN (163.3 mm x 46.7 mm x 59.9 mm BEARING AREA: 10.3 IN ² (66.5 cm ²)	
CABLE TENDON	GALVANIZED STEEL	DIAMETER: 0.1875 IN (4.8 mm)	
LOWER TERMINATION	ALUMINUM	LENGTH: 0.85 IN (16.55 mm) WALL THICKNESS: 0.11 IN (2.8 mm)	
LOAD BEARING PLATE	ZINC-ALUMINUM	5.98 IN x 6.6 IN x 0.75 IN (151.9 mm x 167.6 mm x 19.1 mm) BEARING AREA: 17.43 IN ² (112.5 cm ²)	
TOP TERMINATION	ZINC-ALUMINUM	CIRCUMFERENTIAL TRIPLE WEDGE GRIP ASSEMBLY TO ELIMINATE CABLE PINCH POINTS GRIP TO CABLE CONTACT SURFACE AREA: 0.505 IN ² (3.3 cm ²)	
PERFORMANCE PROPERTIES		GRIP TO CABLE CONTACT RATIO: 97% OF CABLE DIAMETER	
ULTIMATE ASSEMBLY STRENGTH	2800 LB (12.46 kN)	TYPICAL WORKING LOAD	2000 LB (8.9 kN)
ULTIMATE CABLE STRENGTH	3700 LB (16.46 kN)	EMBEDMENT DEPTH	6-12 FT (1.83-3.66 m)

SHOTCRETE MIX DESIGN:

- SHOTCRETE SHALL COMPLY WITH THE REQUIREMENTS OF ACI 506.2, "SPECIFICATIONS FOR MATERIALS, PROPORTIONING AND APPLICATIONS OF SHOTCRETE", EXCEPT AS OTHERWISE SPECIFIED. SHOTCRETING CONSISTS OF APPLYING ONE OR MORE LAYERS OF CONCRETE CONVEYED THROUGH A HOSE PNEUMATICALLY PROJECTED AT A HIGH VELOCITY AGAINST A PREPARED SURFACE.
- THE WET-MIX PROCESS CONSISTS OF THOROUGHLY MIXING ALL THE INGREDIENTS, INTRODUCING THE MIXTURE INTO THE DELIVERY EQUIPMENT, AND DELIVERING IT BY POSITIVE DISPLACEMENT TO THE NOZZLE. AIR JET THE WET-MIX SHOTCRETE FROM THE NOZZLE AT HIGH VELOCITY ONTO THE SURFACE.
- STANDARD SHOTCRETE MIX DESIGN SHALL BE USED UNLESS SHOTCRETE TEMPERATURES ARE ANTICIPATED TO REACH AND/OR EXCEED 85°F. IN THIS EVENT, HOT WEATHER MIX MAY BE USED. SET TIME CONTROLLING ADDITIVES (I.E., HYDRATION STABILIZERS, RETARDERS) MAY BE USED PER THE MANUFACTURER SPECIFICATIONS AND UNDER THE DIRECTION OF THE ENGINEER.
- TYPICAL SHOTCRETE MIX DESIGNS ARE PROVIDED BELOW. OTHER MIX DESIGNS ARE ACCEPTABLE AS APPROVED BY ENGINEER.

STANDARD SHOTCRETE MIX DESIGN (PER YD ³)		
MATERIAL	DESCRIPTON	WEIGHT (LBS)
AGGREGATE NO. 1	3/8" ROCK, AASHTO M80, CLASS B	650
AGGREGATE NO. 2	CONCRETE SAND, CLEAN, NATURAL	1800
AIR	6% TOTAL	-
WATER	CLEAN AND POTABLE	300
FLY ASH	TYPE F OR C	150
CEMENT	TYPE V	750
TOTAL	-	3710

HOT WEATHER SHOTCRETE MIX DESIGN (PER YD ³)		
MATERIAL	DESCRIPTON	WEIGHT (LBS)
AGGREGATE NO. 1	3/8" ROCK, AASHTO M80, CLASS B	650
AGGREGATE NO. 2	CONCRETE SAND, CLEAN, NATURAL	1800
AIR	6% TOTAL	-
WATER	CLEAN AND POTABLE	300
FLY ASH	TYPE F OR C	150
CEMENT	TYPE V	750
TOTAL	-	3710

SHOTCRETE APPLICATION:

- SHOTCRETE APPLICATION WILL GENERALLY COMPLY WITH ACI 506.2-13. UNLESS DIRECTED BY ENGINEER OR THEIR DESIGNATED REPRESENTATIVE.
- SHOTCRETE WILL BE PLACED FROM THE LOWER PART OF THE AREA UPWARDS TO PREVENT ACCUMULATION OF REBOUND. THE NOZZLE WILL BE ORIENTED A PROPER DISTANCE FROM AND APPROXIMATELY PERPENDICULAR TO THE WORKING FACE SO THAT REBOUND WILL BE MINIMAL AND COMPACTION WILL BE MAXIMIZED.
- CARE WILL BE TAKEN WHILE ENCASING REINFORCING STEEL AND MESH TO KEEP THE FROM FACE OF THE REINFORCEMENT CLEAN DURING PLACEMENT, SO THAT SHOTCRETE BUILDS UP FROM BEHIND, TO ENCASE THE REINFORCEMENT AND PREVENT VOIDS OR POCKETS FROM FORMING.
- SHOTCRETE THICKNESS TOLERANCES SHALL BE MINUS ONE INCH - PLUS TWO INCHES.

GROUT MIX DESIGN:

- STANDARD GROUT MIX DESIGN TO BE USED IN SOIL DRILLING.
- IF SLOWER DRILLING IS EXPERIENCED WHILE DRILLING IN ROCK ENGINEER MAY APPROVE THE USE OF DRILLING GROUT MIX DESIGN UPON COMPLETION OF DRILLING TO SPECIFIED DEPTH WITH DRILLING GROUT MIX HOLE SHOULD BE FLUSHED WITH STANDARD GROUT MIX AND NAIL HOLE SWABBED TO AID IN DRILLING GROUT MIX REPLACEMENT.
- IF VOIDS ARE ENCOUNTERED AND GROUT LOSS IS EXPERIENCED CONTACT ENGINEER AND CUT OFF GROUT PUMPING FOR THAT ELEMENT WHEN DRILLING DEPTH IS REACHED AND A TOTAL OF 3 BAGS OF GROUT SLURRY PER 10-FOOT STICK OF BAR HAS BEEN USED.
- THE GROUT WILL BE A TYPE I/II/V PORTLAND CEMENT. THE WATER/CEMENT RATION WILL BE 0.5 TO 0.6. NO ADDITIONAL AGGREGATE OR ADMIXTURES WILL BE ADDED TO THE GROUT.
- TYPICAL GROUT MIX DESIGNS ARE PROVIDED BELOW. OTHER MIX DESIGNS ARE ACCEPTABLE AS APPROVED BY ENGINEER.

STANDARD GROUT MIX DESIGN			
MATERIAL	UNITS:	UNITS:	MINIMUM REQUIREMENT:
THICKNESS	ASTM D6525	IN	0.4
LIGHT PENETRATION	ASTM D6567	%	10
TENSILE STRENGTH	ASTM D6818	LB/FT	4000 X 3000
TENSILE ELONGATION	ASTM 6818	%	40 X 35
RESILIENCY	ASTM 6524	%	80

DRILLING GROUT MIX DESIGN			
MATERIAL	UNITS:	UNITS:	MINIMUM REQUIREMENT:
THICKNESS	ASTM D6525	IN	0.4
LIGHT PENETRATION	ASTM D6567	%	10
TENSILE STRENGTH	ASTM D6818	LB/FT	4000 X 3000
TENSILE ELONGATION	ASTM 6818	%	40 X 35
RESILIENCY	ASTM 6524	%	80

QUALITY CONTROL:

- CONTRACTOR AND/OR ENGINEER WILL CONDUCT OR OBTAIN QUALIFIED PERSONNEL TO CONDUCT THE FOLLOWING QUALITY CONTROL TESTING DURING THE PROJECT.

QUALITY CONTROL SCHEDULE		
DESCRIPTION	FREQUENCY	REFERENCE/CRITERIA
DRILL LOGS	EVERY MICROPILE	RECORD DATA PER SHEET C-14
PROOF NAIL TEST	5% OF PRODUCTION NAILS. TEST AFTER 48 HRS.	FHWA 05-039, 2005
MUD BALANCE READINGS (SPECIFIC GRAVITY)	ONCE EACH DAY OF GROUTING	SEE SHEET C-02 & C-14 FOR MIX DESIGN AND DATA LOG
GROUT CUBES	1 SET OF 3 CUBES PER EVERY 10 PILES INSTALLED	ASTM C-109/AASHTO T106. 3, 7 & 28 DAY STRENGTH. 4000 PSI 28-DAY
SHOTCRETE PANELS	2 PRODUCTION PANELS THROUGHOUT PROJECT	ASTM C1140, 1500 PSI. 3, 7 & 28 DAY STRENGTH. 4000 PSI 28-DAY

SUBMITTALS:

1. THE SHOP DRAWINGS AND DESCRIPTIONS OF THE PROPOSED SEQUENCE OF CONSTRUCTION, THE PROPOSED METHOD OF MICROPILE INSTALLATION AND FOOTING CONSTRUCTION, AND THE DETAILS OF THE GRADING AND BACKFILLING, TO COMPLETE THIS WORK AS SHOWN ON THE PLANS.
2. THE DESIGN CALCULATIONS FOR THE REINFORCED SOIL SLOPE (RSS).
3. THE PROPOSED METHOD(S) AND MATERIALS FOR THE PROTECTION OF THE SURFACE OF THE EXPOSED SLOPE.
4. THE PROPOSED LOCATIONS OF THE LOAD TESTING OF THE THREE NON-PRODUCTION MICROPILES.

AS-BUILT

By _____ Date _____

R.C.E. _____ Exp. _____

	GENERAL NOTES	ENGINEER OF WORK	CITY APPROVED CHANGES	APP'D DATE	RECOMMENDED FOR APPROVAL	APPROVED FOR CONSTRUCTION	BENCH MARK	CITY OF SOLANA BEACH	ENGINEERING DEPARTMENT	DRAWING NO.
		JLW Drawn By	By: Patrick Poepsel, PE Date: _____		By: _____ Date: _____	By: _____ Date: _____ Mohammad Sammak, City Engineer R.C.E.: 37146 Exp: 6/30/16		GRADING PLANS FOR: LAS BRISAS CONDOMINIUMS		C-02
								ELEV: _____ DATUM: M.S.L.		Sheet 2 of 13

GENERAL:

- APPROVAL OF THIS GRADING PLAN DOES NOT CONSTITUTE APPROVAL OF VERTICAL OR HORIZONTAL ALIGNMENT OF ANY PRIVATE ROAD SHOWN HEREIN FOR PUBLIC ROAD PURPOSES.
- FINAL APPROVAL OF THESE GRADING PLANS IS SUBJECT TO FINAL APPROVAL OF THE ASSOCIATED IMPROVEMENT PLANS WHERE APPLICABLE. FINAL CURB GRADE ELEVATIONS MAY REQUIRE CHANGES IN THESE PLANS.
- IMPORT MATERIALS SHALL BE LEGALLY OBTAINED.
- A SEPARATE PERMIT FROM THE CITY ENGINEER WILL BE REQUIRED FOR ANY WORK IN THE PUBLIC RIGHT-OF-WAY.
- ALL SLOPES OVER THREE FEET IN HEIGHT SHALL BE LANDSCAPED AND IRRIGATED.
- THE CONTRACTOR SHALL VERIFY THE EXISTENCE AND LOCATION OF ALL UTILITIES BEFORE COMMENCING WORK. NOTICE OF PROPOSED WORK SHALL BE GIVEN TO THE FOLLOWING AGENCIES:

UNDERGROUND SERVICE ALERT 811

- THE SOILS REPORT TITLED _____, PREPARED BY _____, AND DATED _____, SHALL BE CONSIDERED AS PART OF THIS GRADING PLAN. ALL GRADING SHALL BE DONE IN ACCORDANCE WITH THE RECOMMENDATIONS AND SPECIFICATIONS CONTAINED IN SAID REPORT.
- APPROVAL OF THESE PLANS BY THE CITY ENGINEER DOES NOT AUTHORIZE ANY WORK OR GRADING TO BE PERFORMED UNTIL THE PROPERTY OWNER'S PERMISSION HAS BEEN OBTAINED AND A VALID GRADING PERMIT HAS BEEN ISSUED.
- THE CITY ENGINEER'S APPROVAL OF THESE PLANS DOES NOT CONSTITUTE THE BUILDING OFFICIAL'S APPROVAL OF ANY FOUNDATION FOR STRUCTURES TO BE PLACED ON THE AREA COVERED BY THESE PLANS. NO WAIVER OF THE GRADING ORDINANCE REQUIREMENTS CONCERNING MINIMUM COVER OVER EXPANSIVE SOILS IS MADE OR IMPLIED.
- ALL OPERATIONS CONDUCTED ON THE PREMISES, INCLUDING THE WARMING UP, REPAIR, ARRIVAL, DEPARTURE OR RUNNING OF TRUCKS, EARTHMOVING EQUIPMENT, CONSTRUCTION EQUIPMENT, AND ANY OTHER ASSOCIATED GRADING EQUIPMENT SHALL BE LIMITED TO THE PERIOD BETWEEN 7:00 A.M. AND 6:00 P.M. EACH DAY, MONDAY THROUGH FRIDAY, AND NO EARTHMOVING OR GRADING OPERATIONS SHALL BE CONDUCTED ON THE PREMISES ON SATURDAYS, SUNDAYS, OR HOLIDAYS WITHOUT THE WRITTEN PERMISSION OF THE CITY ENGINEER.
- ALL MAJOR SLOPES SHALL BE ROUNDED INTO EXISTING TERRAIN TO PRODUCE A CONTOURED TRANSITION FROM CUT OR FILL SURFACES TO NATURAL GROUND AND ADJUTING CUT OR FILL SURFACES.
- NOTWITHSTANDING THE MINIMUM STANDARDS SET FORTH IN THE EXCAVATION AND GRADING CODE, AND NOTWITHSTANDING THE APPROVAL OF THESE GRADING PLANS, THE PERMITEE IS RESPONSIBLE FOR THE PREVENTION OF DAMAGE TO THE ADJACENT PROPERTY. NO PERSON SHALL EXCAVATE ON LAND SO CLOSE TO THE PROPERTY LINE AS TO ENDANGER ANY ADJOINING PUBLIC STREET, SIDEWALK, ALLEY, FUNCTION OF ANY SEWAGE DISPOSAL SYSTEM, OR ANY OTHER PUBLIC OR PRIVATE PROPERTY WITHOUT SUPPORTING AND PROTECTING SUCH PROPERTY FROM SETTling, CRACKING, EROSION, SILTING SCOUR, OR OTHER DAMAGE WHICH MIGHT RESULT FROM THE GRADING DESCRIBED ON THIS PLAN. THE CITY WILL HOLD THE PERMITEE RESPONSIBLE FOR CORRECTION ON NON-DEDICATED IMPROVEMENTS, WHICH DAMAGE ADJACENT PROPERTY.
- SLOPE RATIOS: CUT 2:1 FILL 2:1
CUT: _____CY. FILL: _____CY.
IMPORT/(EXPORT): _____CY.
NOTE: A SEPARATE PERMIT MUST EXIST FOR OFFSITE IMPORT OR EXPORT AREAS.
- SPECIAL CONDITIONS: IF ANY ARCHEOLOGICAL RESOURCES ARE DISCOVERED ON THE SITE OF THIS GRADING DURING GRADING OPERATIONS, SUCH OPERATIONS WILL CEASE IMMEDIATELY AND THE PERMITEE WILL NOTIFY THE CITY ENGINEER OF THE DISCOVERY. GRADING OPERATIONS WILL NOT COMMENCE UNTIL THE PERMITEE HAS RECEIVED WRITTEN AUTHORITY FROM THE CITY ENGINEER TO DO SO.
- ALL GRADING SHOWN ON THIS PLAN SHALL BE COMPLETED AS A SINGULAR UNIT WITH NO PROVISION FOR PARTIAL RELEASES. SHOULD IT BE ANTICIPATED THAT A PORTION OF THIS PROJECT IS COMPLETED SEPARATELY, A SEPARATE PLAN AND PERMIT APPLICATION SHALL BE SUBMITTED FOR APPROVAL.
- THE CONTRACTOR SHALL NOTIFY THE CITY OF SOLANA BEACH AT (858) 720-2470, 24 HOURS BEFORE GRADING OPERATIONS BEGIN.
- FINISHED GRADING AND PLANTING SHALL BE ACCOMPLISHED ON ALL SLOPES PRIOR TO OCTOBER 1, OR IMMEDIATELY UPON COMPLETION OF ANY SLOPES GRADED BETWEEN OCTOBER 1 AND APRIL 1. PRIOR TO ANY PLANTING, ALL LANDSCAPING SHALL BE APPROVED BY THE PLANNING DEPARTMENT AT THE DEVELOPMENT REVIEW STAGE, OR BY SEPARATE LANDSCAPING PLAN.
- ALL OFF-SITE HAUL ROUTES SHALL BE SUBMITTED BY THE CONTRACTOR TO THE CITY ENGINEER FOR APPROVAL 72 HOURS PRIOR TO BEGINNING WORK.
- UPON FINAL COMPLETION OF THE WORK UNDER THE GRADING PERMIT, BUT PRIOR TO FINAL GRADING APPROVAL AND/OR FINAL RELEASE OF SECURITY, AN AS-GRADED CERTIFICATE SHALL BE PROVIDED STATING: "THE GRADING UNDER PERMIT NO. SBGR-_____ HAS BEEN PERFORMED IN SUBSTANTIAL CONFORMANCE WITH THE APPROVED GRADING PLAN OR AS SHOWN ON THE ATTACHED AS-GRADED PLAN." THIS STATEMENT SHALL BE FOLLOWED BY THE DATE AND SIGNATURE OF THE CIVIL ENGINEER WHO CERTIFIES SUCH GRADING OPERATION.
- THE CONTRACTOR SHALL DESIGN, CONSTRUCT AND MAINTAIN ALL SAFETY DEVICES INCLUDING SHORING, AND SHALL BE SOLELY RESPONSIBLE FOR CONFORMING TO ALL LOCAL, STATE AND FEDERAL SAFETY AND HEALTH STANDARDS, LAWS AND REGULATIONS.

EROSION CONTROL NOTES:

- STORM WATER AND NON-STORM WATER DISCHARGE CONTROL: BEST MANAGEMENT PRACTICES SHALL BE DEVELOPED AND IMPLEMENTED TO MANAGE STORM WATER AND NON-STORM WATER DISCHARGES FROM THE SITE AT ALL TIMES DURING EXCAVATION AND GRADING ACTIVITIES.
- EROSION AND SEDIMENT CONTROL: EROSION PREVENTION SHALL BE EMPHASIZED AS THE MOST IMPORTANT MEASURE FOR KEEPING SEDIMENT ON SITE DURING EXCAVATION AND GRADING ACTIVITIES. SEDIMENT CONTROLS SHALL BE USED AS A SUPPLEMENT TO EROSION PREVENTION FOR KEEPING SEDIMENT ON SITE.
- EROSION CONTROL ON SLOPES SHALL BE MITIGATED BY INSTALLING LANDSCAPING AS PER APPROVED LANDSCAPE PLANS AS REQUIRED BY THE DEVELOPMENT REVIEW CONDITIONS, OR BY TEMPORARY EROSION CONTROL CONFORMING TO THE FOLLOWING:

NON-IRRIGATED HYDROSEED MIX WITH A BONDED FIBER MATRIX APPLIED AT 4,000 LB/ACRE		
LBS/ACRE	% PURITY/ACRE	SEED SPECIES
20	70% PLUS	ATRIplex GLAUCA
50		PLANTAGE INSULARIS
8		ENCELUS FARINOSA
6	SCARIFIED	LOTUS SCOPARIUS
7	50% PLUS	EXCHSCHOLZIA CALIFORNIA
TOTAL	91 LBS	

- THE TOPS OF ALL SLOPES TALLER THAN 5' SHALL BE DIKED OR TRENCHED TO PREVENT WATER FLOWING OVER CRESTS OF SLOPES.
- CATCH BASINS, DESILTING BASINS AND STORM DRAIN SYSTEMS SHALL BE INSTALLED TO THE SATISFACTION OF THE CITY ENGINEER.
- SAND BAG CHECK DAMS, SILT FENCES, FIBER ROLLS OR OTHER APPROVED BMP'S SHALL BE PLACED IN UNPAVED AREAS WITH GRADIENTS IN EXCESS OF 2%, AS WELL AS AT OR NEAR EVERY POINT WHERE CONCENTRATED FLOW LEAVE THE SITE.
- SAND BAGS SHALL BE PLACED ON THE UPSTREAM SIDE OF ALL DRAINAGE INLETS TO MINIMIZE SILT BUILDUP IN THE INLETS AND PIPES.
- THE CONTRACTOR SHALL REPAIR ANY ERODED SLOPES AS DIRECTED BY THE OFFICE OF THE CITY ENGINEER.
- THE CONTRACTOR SHALL SWEEP ROADWAYS AND ENTRANCES TO AND FROM THE SITE ON A REGULAR BASIS TO KEEP THEM FREE OF SOIL ACCUMULATION AND AT ALL OTHER TIMES DIRECTED BY THE CITY ENGINEER.
- THE CONTRACTOR SHALL WATER SITE ON A CONTINUOUS BASIS TO MINIMIZE AIR BORNE DUST CREATED FROM GRADING AND HAULING OPERATIONS OR EXCESSIVE WIND CONDITIONS, AND AT ALL TIMES DIRECTED BY THE CITY ENGINEER.
- IN THE EVENT SILT DOES ENTER THE EXISTING PUBLIC STORM DRAIN SYSTEM, REMOVAL OF THE SILT FROM THE SYSTEM WILL BE AT THE DEVELOPER'S EXPENSE.

AS-BUILT:

UPON COMPLETION, AND PRIOR TO RELEASING THE SECURITIES, THE ENGINEER OF WORK SHALL "AS-BUILT" THE ORIGINAL MYLAR PLANS. INITIALLY, TWO COPIES OF RED-LINED PLANS SHOWING ALL AS-BUILT INFORMATION, INCLUDING ALL NEW UNDERGROUND FACILITIES (MAIN LINES, SERVICES AND LATERALS), IS TO BE SUBMITTED TO THE ENGINEERING DEPARTMENT. WHEN THE RED-LINES ARE APPROVED, THE ORIGINAL MYLAR PLANS WILL BE CHECKED OUT TO THE ENGINEER. THE ENGINEER SHALL MAKE THE CHANGES, SIGN EACH SHEET UNDER "AS-BUILT", AND RETURN ORIGINAL MYLARs TO THE CITY.

OWNER/DEVELOPER CERTIFICATE:

I, _____ AS OWNER/DEVELOPER OF THE PROPERTY DESCRIBED HEREIN ACKNOWLEDGE THESE PLANS HAVE BEEN PREPARED AT MY DIRECTION WITH MY FULL CONSENT. I FULLY UNDERSTAND AND ACCEPT THE TERMS AND CONDITIONS CONTAINED HEREIN AND AS ATTACHED BY REFERENCE ON THIS GRADING PLAN. IT IS AGREED THAT FIELD CONDITIONS MAY REQUIRE CHANGES TO THESE PLANS. IT IS FURTHER AGREED THAT THE OWNER/DEVELOPER SHALL HAVE A REGISTERED CIVIL ENGINEER MAKE SUCH CHANGES, ALTERATIONS OR ADDITIONS TO THESE PLANS WHICH THE CITY ENGINEER DETERMINES ARE NECESSARY AND DESIRABLE FOR THE PROPER COMPLETION OF THE IMPROVEMENTS. I FURTHER AGREE TO COMMENCE WORK ON ANY IMPROVEMENTS SHOWN ON THESE PLANS WITHIN EXISTING CITY RIGHT-OF-WAY WITHIN 9 MONTHS AFTER ISSUANCE OF THE CONSTRUCTION PERMIT AND TO PURSUE SUCH WORK ACTIVELY ON EVERY NORMAL WORKING DAY UNTIL COMPLETED, IRRESPECTIVE AND INDEPENDENT OF ANY OTHER WORK ASSOCIATED WITH THIS PROJECT OR UNDER MY CONTROL.

SIGNED _____ DATE _____

ENGINEER OF WORK CERTIFICATE:

I, _____ HEREBY DECLARE THAT I AM THE ENGINEER OF WORK FOR THIS PROJECT, THAT I HAVE EXERCISED RESPONSIBLE CHARGE OVER THE DESIGN OF THE PROJECT AS DEFINED IN SECTION 6703 OF THE BUSINESS AND PROFESSIONS CODE, AND THE DESIGN IS CONSISTENT WITH CURRENT STANDARDS AND CITY OF SOLANA BEACH RESOLUTION NO. _____

I UNDERSTAND THAT THE CHECK OF PROJECT DRAWINGS AND SPECIFICATIONS BY THE CITY OF SOLANA BEACH AND ANY OTHER PUBLIC AGENCY IS CONFINED TO A REVIEW ONLY AND DOES NOT RELIEVE ME OF RESPONSIBILITIES FOR PROJECT DESIGN.

SIGNED _____ DATE _____

R.C.E. NO. _____ EXP. _____

FIRM _____

ADDRESS _____

TELEPHONE _____

ENGINEER OF WORK CERTIFICATE AS-BUILT CERTIFICATE:

I, _____ HEREBY DECLARE THAT THE PREPARATION OF THESE AS-BUILT DRAWINGS AND THAT THE INFORMATION SHOWN IS BASED ON ACTUAL SITE INVESTIGATIONS AND SURVEYS OF THE IMPROVEMENTS BETWEEN THE DATES OF _____ AND _____. TO THE BEST OF MY KNOWLEDGE AND EXPERIENCE THE INFORMATION SHOWN ON THESE PLANS PROVIDE AN ACCURATE AND CORRECT REPRESENTATION OF THE AS-BUILT CONDITIONS.

SIGNED _____ DATE _____

R.C.E. NO. _____ EXP. _____

FLOOD STATEMENT:

I, _____ A REGISTERED CIVIL ENGINEER/SURVEYOR, HEREBY CERTIFY THAT THE PAD STRUCTURES SHOWN ON THIS AS-BUILT GRADING PLAN HAVE BEEN VERIFIED BY ME AND THAT SAID ELEVATIONS ARE AT OR ABOVE THE BASE FLOOD ELEVATION SHOWN ON THE FLOOD INSURANCE RATE MAP OF THE COUNTY OF SAN DIEGO.

SIGNED _____ DATE _____

R.C.E./P.L.S. NO. _____ EXP. _____

SOIL ENGINEER CERTIFICATE:

I, _____ A REGISTERED CIVIL ENGINEER OF THE STATE OF CALIFORNIA, PRINCIPALLY DOING BUSINESS IN THE FIELD OF APPLIED SOIL MECHANICS, HEREBY CERTIFY THAT A SAMPLING AND STUDY OF THE SOIL AND CONDITIONS PREVALENT WITHIN THE SITE WAS MADE BY ME OR UNDER MY DIRECTION BETWEEN THE DATES _____ AND _____. I HAVE REVIEWED THE PROJECT DESIGN AND GRADING SHOWN HEREIN IS CONSISTENT WITH THE RECOMMENDATIONS CONTAINED IN THE APPROVED SOILS AND GEOTECHNICAL REPORTS FOR THE PROJECT. ONE COMPLETE COPY OF THE FINAL SOILS REPORT COMPILED FROM THIS STUDY, WITH MY RECOMMENDATIONS, HAS BEEN SUBMITTED TO THE OFFICE OF THE CITY ENGINEER.

SIGNED _____ DATE _____

R.C.E. NO. _____ EXP. _____

ADDRESS _____

TELEPHONE _____

SOIL ENGINEER AS-BUILT CERTIFICATE:

TO THE BEST OF MY KNOWLEDGE AND EXPERIENCE THE GRADING CONFORMS WITH THE RECOMMENDATIONS CONTAINED IN THE SOILS REPORT AND PLANS WITH THE EXCEPTION THAT ANY CHANGES OR DEVIATIONS FROM THE PLANS DUE TO UNFORESEEN FIELD CONDITIONS HAVE BEEN IDENTIFIED IN THE FINAL SOILS REPORT FOR THE PROJECT. ONE COMPLETE COPY OF THE FINAL SOILS REPORT COMPILED FROM THIS STUDY, WITH MY RECOMMENDATIONS, HAS BEEN SUBMITTED TO THE OFFICE OF THE CITY ENGINEER.

SIGNED _____ DATE _____

R.C.E./P.L.S. NO. _____ EXP. _____

WORK TO BE DONE:

THE IMPROVEMENTS CONSIST OF THE FOLLOWING WORK TO BE DONE ACCORDING TO THESE PLANS AND THE LATEST EDITIONS OF:

STANDARD SPECIFICATIONS

- STANDARD SPECIFICATIONS FOR PUBLIC WORKS CONSTRUCTION INCLUDING THE REGIONAL SUPPLEMENTAL AMENDMENTS.
- CALIFORNIA DEPARTMENT OF TRANSPORTATION "MANUAL OF TRAFFIC CONTROLS FOR CONSTRUCTION AND MAINTENANCE WORK ZONES"
- STATE OF CALIFORNIA, DEPARTMENT OF TRANSPORTATION STANDARD SPECIFICATIONS

STANDARD DRAWINGS

- SAN DIEGO REGIONAL STANDARD DRAWINGS
- STATE OF CALIFORNIA, DEPARTMENT OF TRANSPORTATION STANDARD PLANS

AS-BUILT

By _____ Date _____
R.C.E. _____ Exp _____

	GENERAL NOTES (2)	ENGINEER OF WORK	CITY APPROVED CHANGES	APP'D DATE	RECOMMENDED FOR APPROVAL	APPROVED FOR CONSTRUCTION	BENCH MARK	CITY OF SOLANA BEACH	ENGINEERING DEPARTMENT	DRAWING NO.
		JLW Drawn By	By: Patrick Poepffel, PE Date: _____		By: _____ Date _____	By: _____ Date _____ Mohammad Sammak, City Engineer R.C.E. 37146 Exp. 6/30/16		DESCRIPTION LOCATION ELEV. DATUM: M.S.L.		C-03 Sheet 3 of 13



NOTES:

1. BACKGROUND IMAGE OBTAINED FROM GOOGLE EARTH ON 11/13/2023
2. THE REINFORCED SOIL SLOPE SHALL BE DESIGNED IN GENERAL ACCORDANCE WITH THE FHWA DOCUMENT "GEC 11 - DESIGN AND CONSTRUCTION OF MECHANICALLY STABILIZED EARTH WALLS AND REINFORCED SLOPES," VOLUME 1 & 2, FHWA-NHI-10-024. A DESIGN EARTHQUAKE ACCELERATION OF 0.15g SHALL BE INCORPORATED INTO THE DESIGN OF THE RSS SYSTEM. CALCULATIONS FOR THE DESIGN OF THE RSS SHALL BE PREPARED BY A REGISTERED CIVIL GEOTECHNICAL ENGINEER IN THE STATE OF CALIFORNIA AND SHALL BE SUBMITTED AT LEAST 14 DAYS PRIOR TO THE START OF THIS CONSTRUCTION.

CUTOFF WALL
X51 MICROPILES 18" C-C WITH 8"
REINFORCED SHOTCRETE WALL
PLUS 4" OF SCULPTED

EVERY 4TH SOIL NAIL
SHALL BE BATTERED TO THE
NORTH SIDE OF THE WALL

REINFORCED SOIL SLOPE (RSS) BEHIND
REINFORCED MICROPILE AND SHOTCRETE
WALL UTILIZING PROPEX PYRAWALL SYSTEM

APPROXIMATE LOCATION
OF EXISTING TIED-BACK
SEAWALL T.O.W. ELEV 35' +/-

MATCH EXISTING GRADE

A
C-10

A
C-05

A
C-06

AS-BUILT

By: _____ Date: _____
R.C.E. _____ Exp. _____

	PROJECT SITE PLAN	ENGINEER OF WORK	CITY APPROVED CHANGES	APP'D DATE	RECOMMENDED FOR APPROVAL	APPROVED FOR CONSTRUCTION	BENCH MARK	CITY OF SOLANA BEACH	ENGINEERING DEPARTMENT	DRAWING NO.
		JLW Drawn By	By: Patrick Poepsel, PE Date: _____		By: _____ Date: _____	By: Mohammad Sammak, City Engineer R.C.E.: 37146 Exp: 6/30/16		GRADING PLANS FOR: LAS BRISAS CONDOMINIUMS		C-05 Sheet 5 of 13

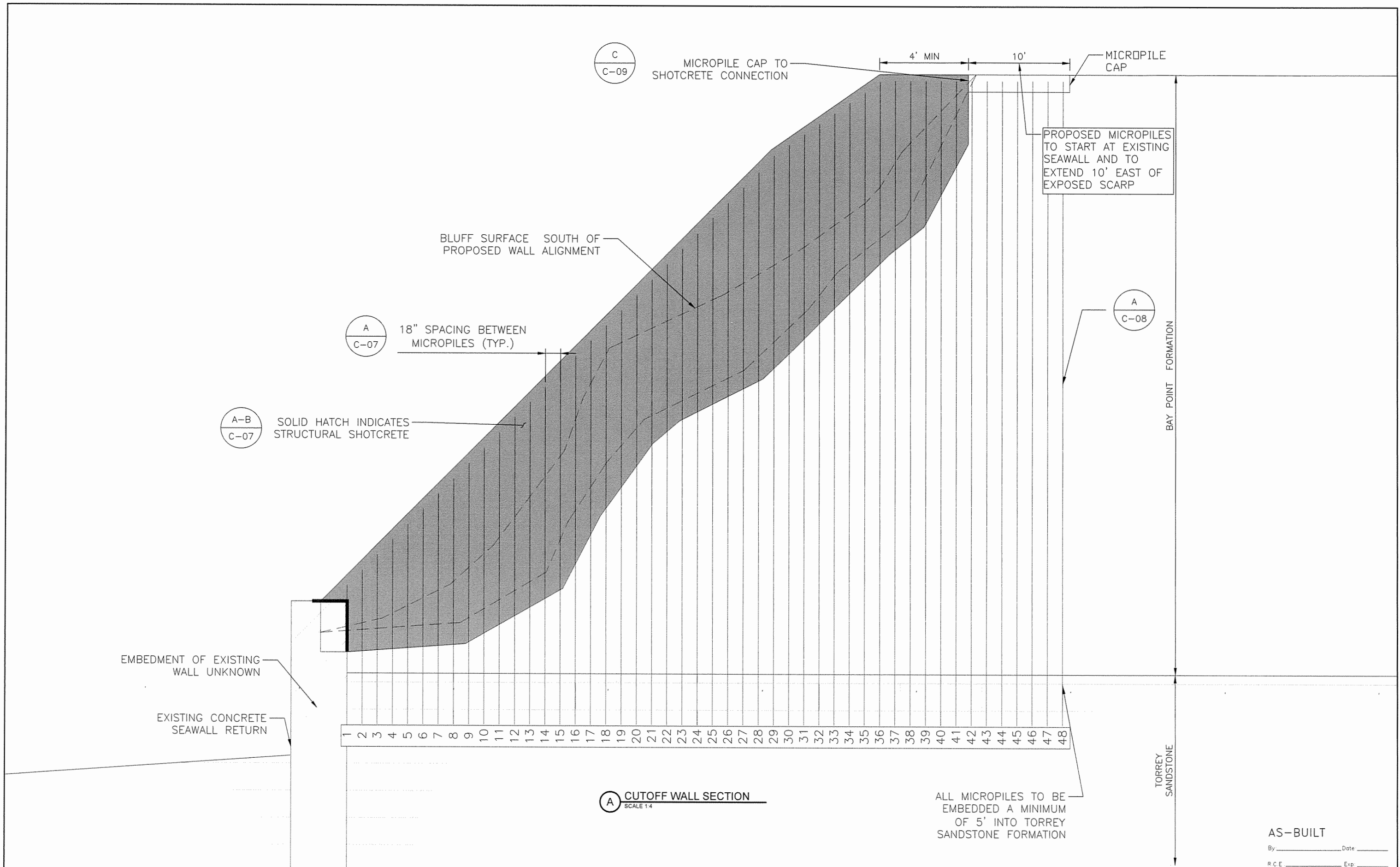

A CUTOFF WALL SECTION
SCALE 1/4

ALL MICROPILES TO BE EMBEDDED A MINIMUM OF 5' INTO TORREY SANDSTONE FORMATION

AS-BUILT
By: _____ Date: _____
R.C.E. _____ Exp: _____

	SECTION VIEW - CUTOFF WALL	ENGINEER OF WORK	CITY APPROVED CHANGES	APP'D DATE	RECOMMENDED FOR APPROVAL	APPROVED FOR CONSTRUCTION	BENCH MARK	CITY OF SOLANA BEACH	ENGINEERING DEPARTMENT	DRAWING NO.
	Drawn By: _____	By: _____ Date: _____			By: _____ Date: _____	By: <u>Mohammad Sammal, City Engineer</u> R.C.E. 37146 Exp. 6/30/16		GRADING PLANS FOR: LAS BRISAS CONDOMINIUMS		C-06
										Sheet 6 of 13

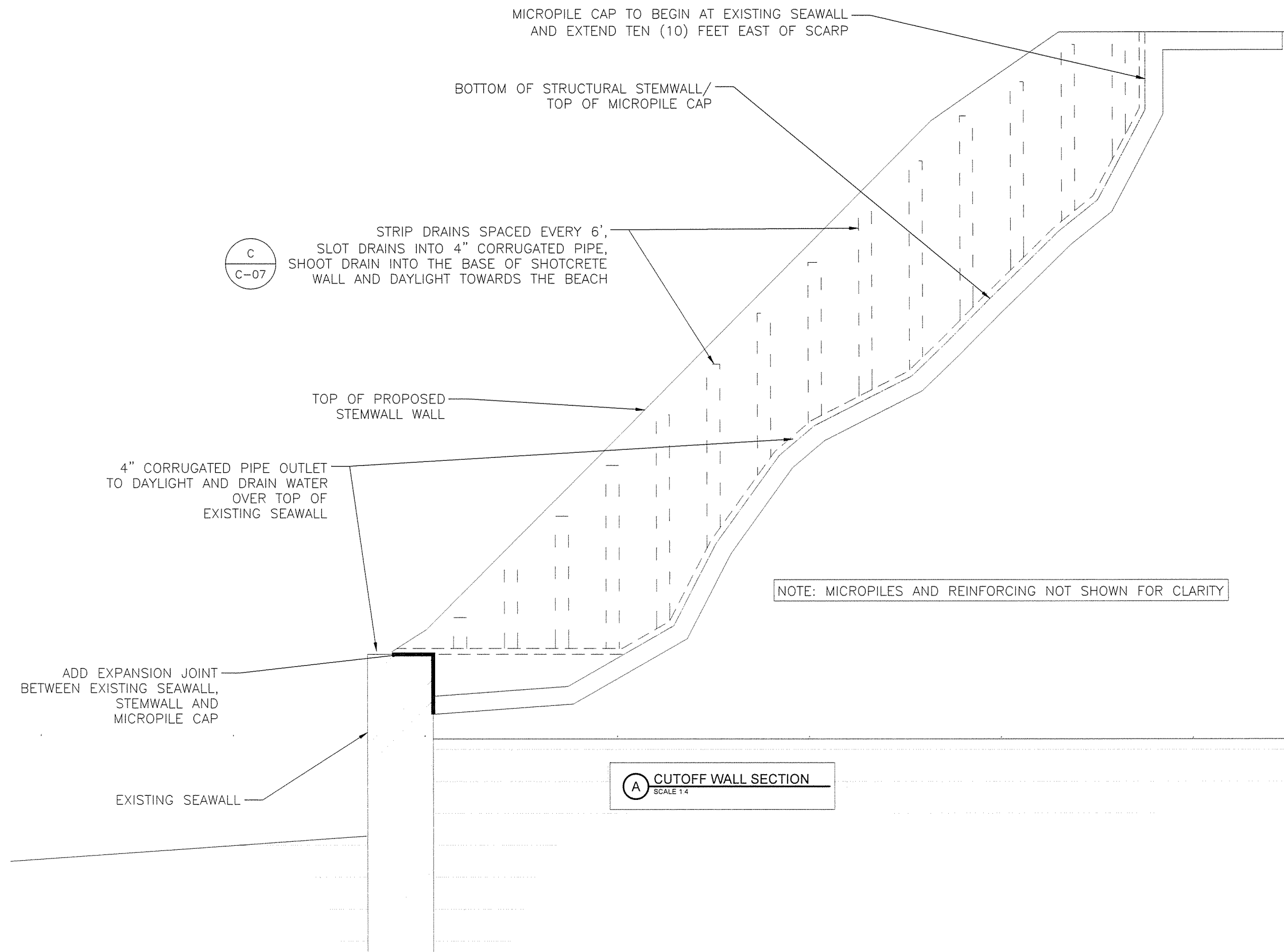

C
C-07

NOTE: MICROPILES AND REINFORCING NOT SHOWN FOR CLARITY

A CUTOFF WALL SECTION
SCALE 1/4

AS-BUILT
By _____ Date _____
R.C.E. _____ Exp. _____

	CUTOFF WALL DETAILS	ENGINEER OF WORK	CITY APPROVED CHANGES	APP'D DATE	RECOMMENDED FOR APPROVAL	APPROVED FOR CONSTRUCTION	BENCH MARK	CITY OF SOLANA BEACH	ENGINEERING DEPARTMENT	DRAWING NO.
		JLW Drawn By	By: Patrick Poeschel, PE Date: _____		By: _____ Date: _____	By: Mohammad Sammak, City Engineer R.C.E. 37146 Exp. 6/30/16		GRADING PLANS FOR LAS BRISAS CONDOMINIUMS		C-07 Sheet 7 of 13

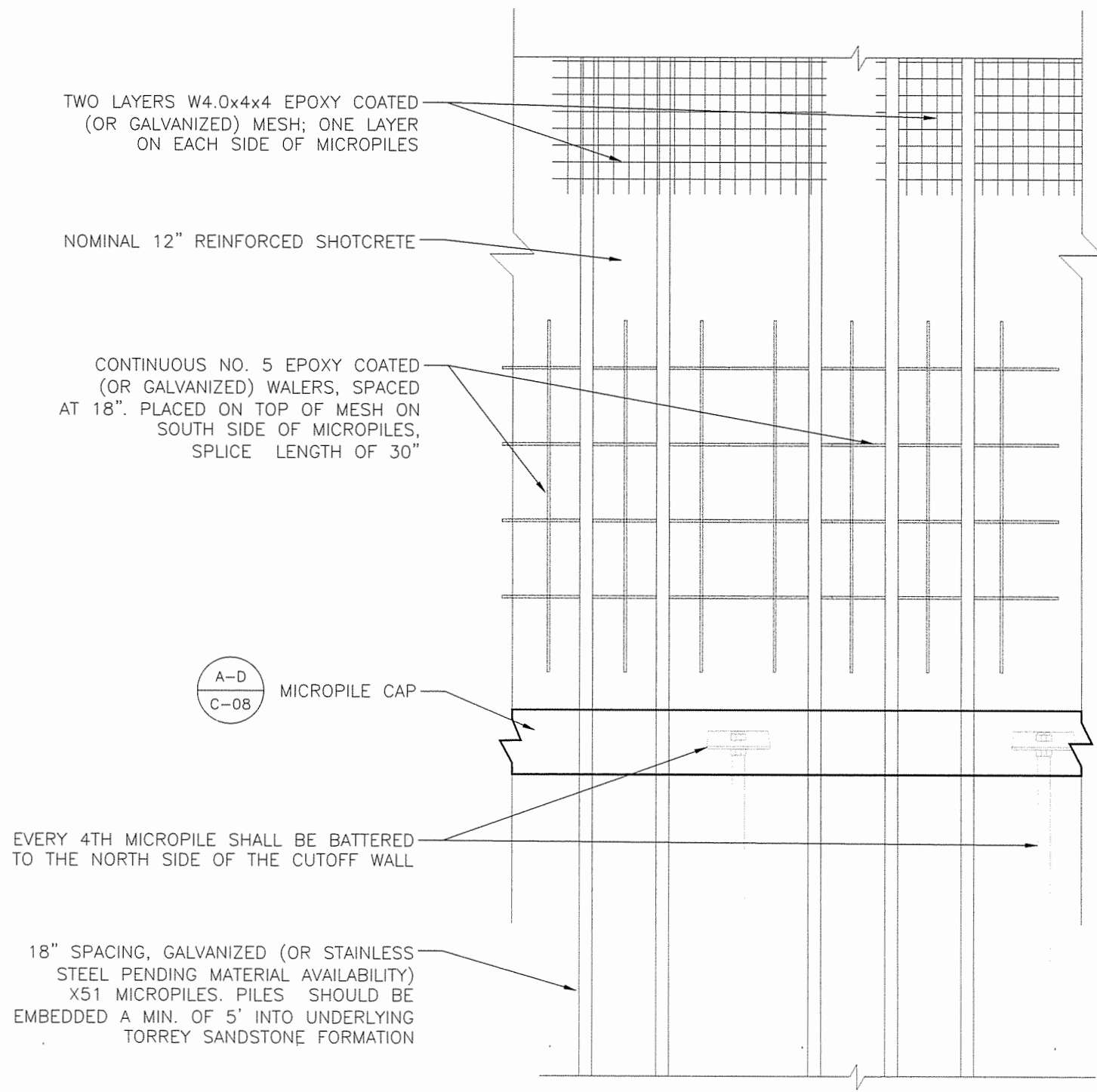

(A) ELEVATION VIEW
Not To Scale

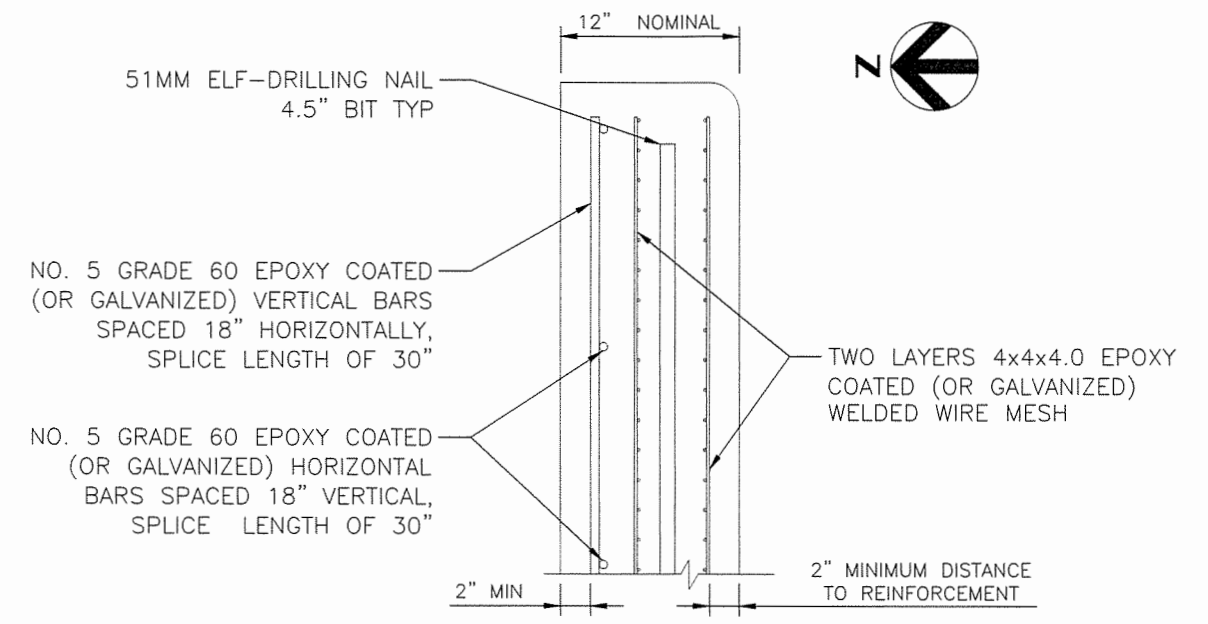

(B) SECTIONAL VIEW
Not To Scale

NOTE: SEE PAGE C-08, SECTIONS B & D FOR PILE CAP DETAILS AT BOTTOM OF WALL

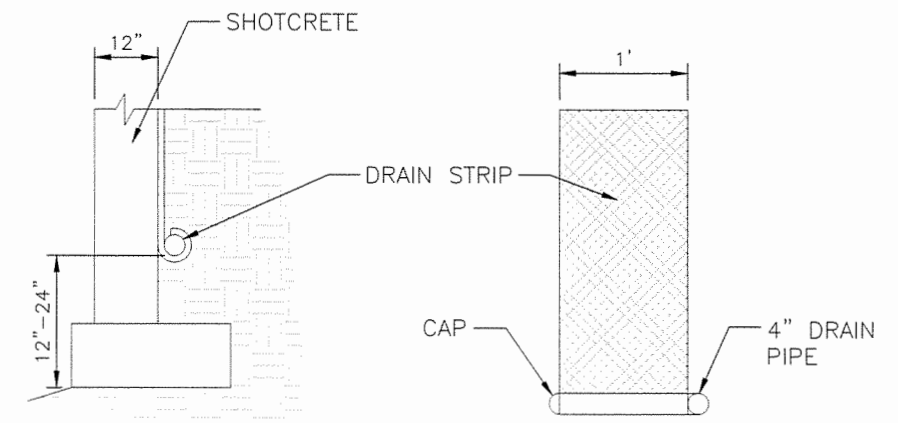

SIDE VIEW

FRONT VIEW

(C) DRAIN CONNECTION DETAIL
Not To Scale

AS-BUILT
By: _____ Date: _____
R.C.E. _____ Exp: _____

	MICROPILE ANCHOR DETAILS	ENGINEER OF WORK	CITY APPROVED CHANGES	APP'D DATE	RECOMMENDED FOR APPROVAL	APPROVED FOR CONSTRUCTION	BENCH MARK	CITY OF SOLANA BEACH	ENGINEERING DEPARTMENT	DRAWING NO.
		JLW Drawn By	By: Patrick Poepsel, PE Date: _____		By: _____ Date: _____	By: Mohammad Sammak, City Engineer R.C.E.: 37146 Exp: 6/30/16		GRADING PLANS FOR: LAS BRISAS CONDOMINIUMS		C-08
								DATUM: M.S.L.		Sheet 8 of 13

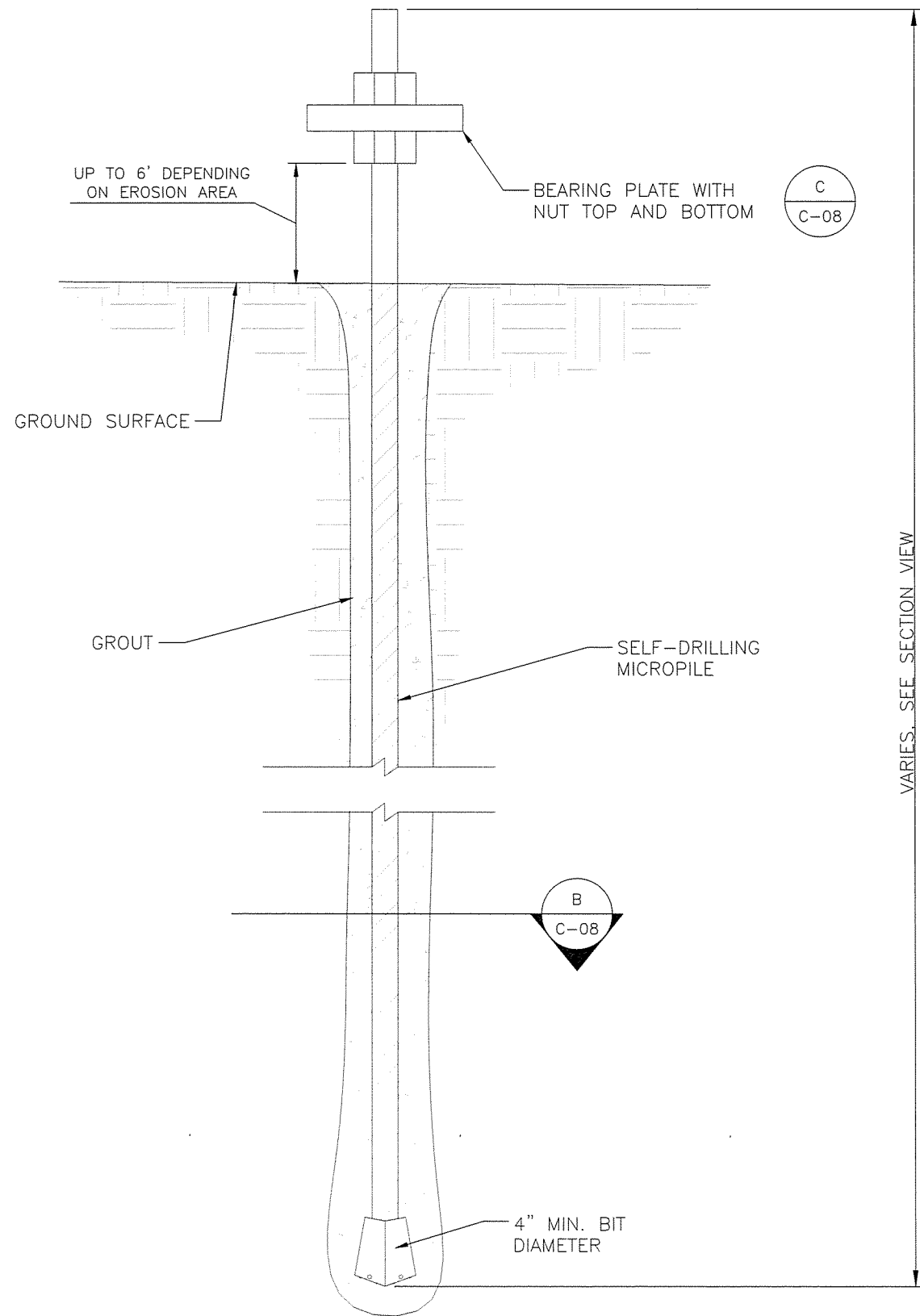

A ANCHOR DETAIL
Not To Scale

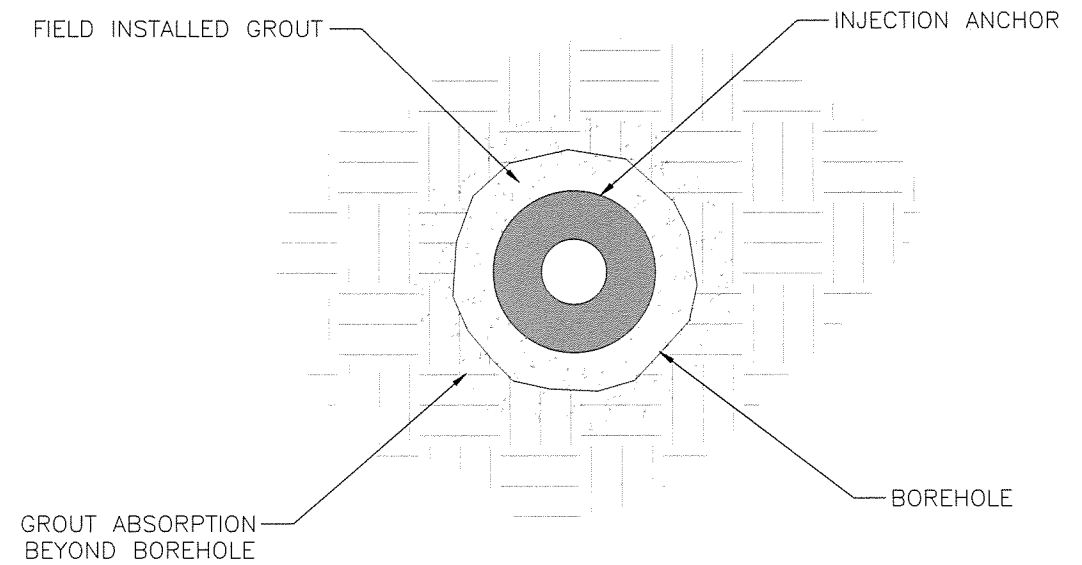

B MICROPILE SECTION
Not To Scale

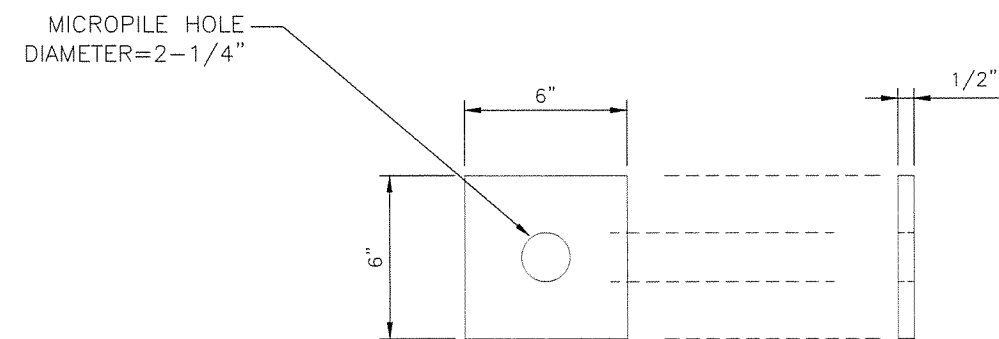

C MICROPILE BEARING PLATE
Not To Scale

AS-BUILT
By: _____ Date: _____
R.C.E. _____ Exp. _____

	SECTION VIEW - CUTOFF WALL	ENGINEER OF WORK	CITY APPROVED CHANGES	APP'D DATE	RECOMMENDED FOR APPROVAL	APPROVED FOR CONSTRUCTION	BENCH MARK	CITY OF SOLANA BEACH	ENGINEERING DEPARTMENT	DRAWING NO.
		JLW Drawn By	By: Patrick Poepel, PE Date: _____		By: _____ Date: _____	By: Mohammad Sammak, City Engineer R.C.E. 37146 Exp. 6/30/16		GRADING PLANS FOR LAS BRISAS CONDOMINIUMS		C-09 Sheet 9 of 13

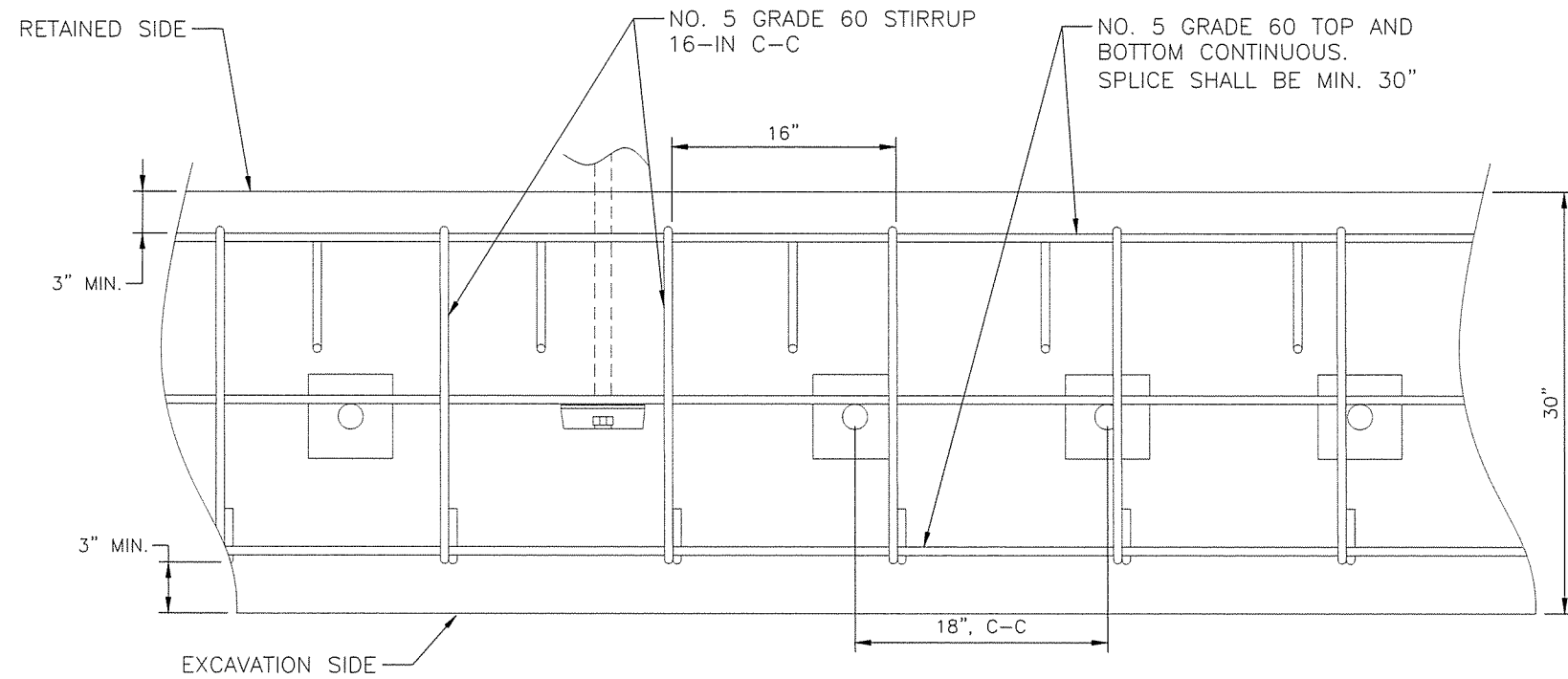

A MICROPILE - TOP VIEW
Not To Scale

EXTEND HOLLOW BAR SUFFICIENTLY TO ALLOW PLACEMENT OF COUPLER WHICH WILL DEVELOP FULL STRENGTH OF BAR

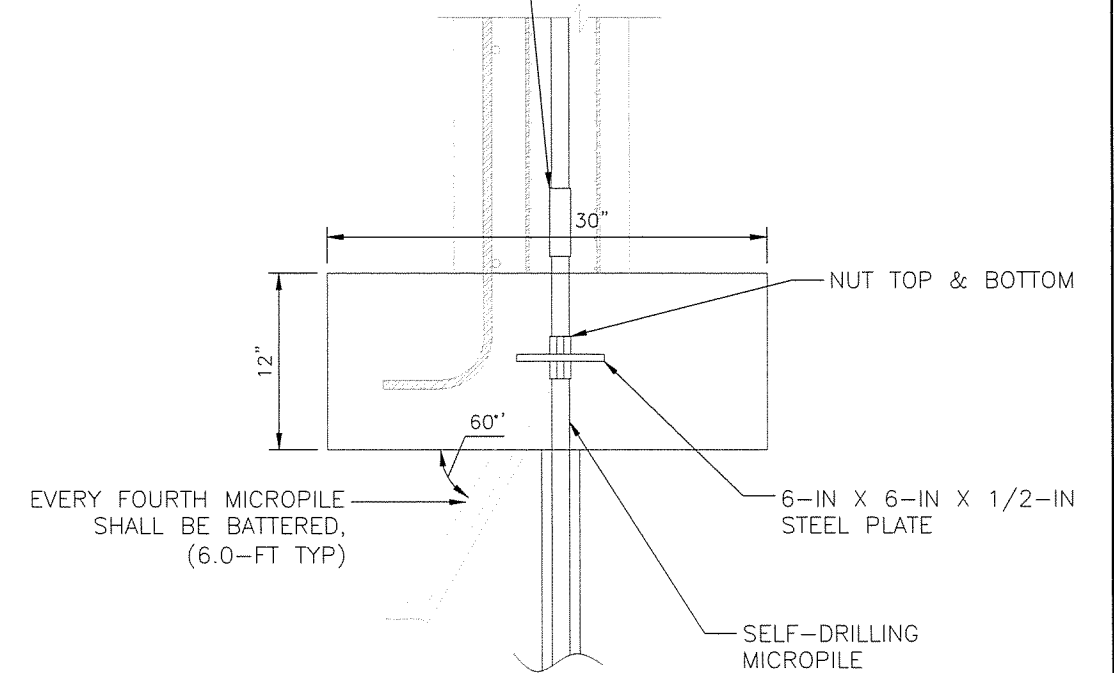

B MICROPILE - END VIEW
Not To Scale

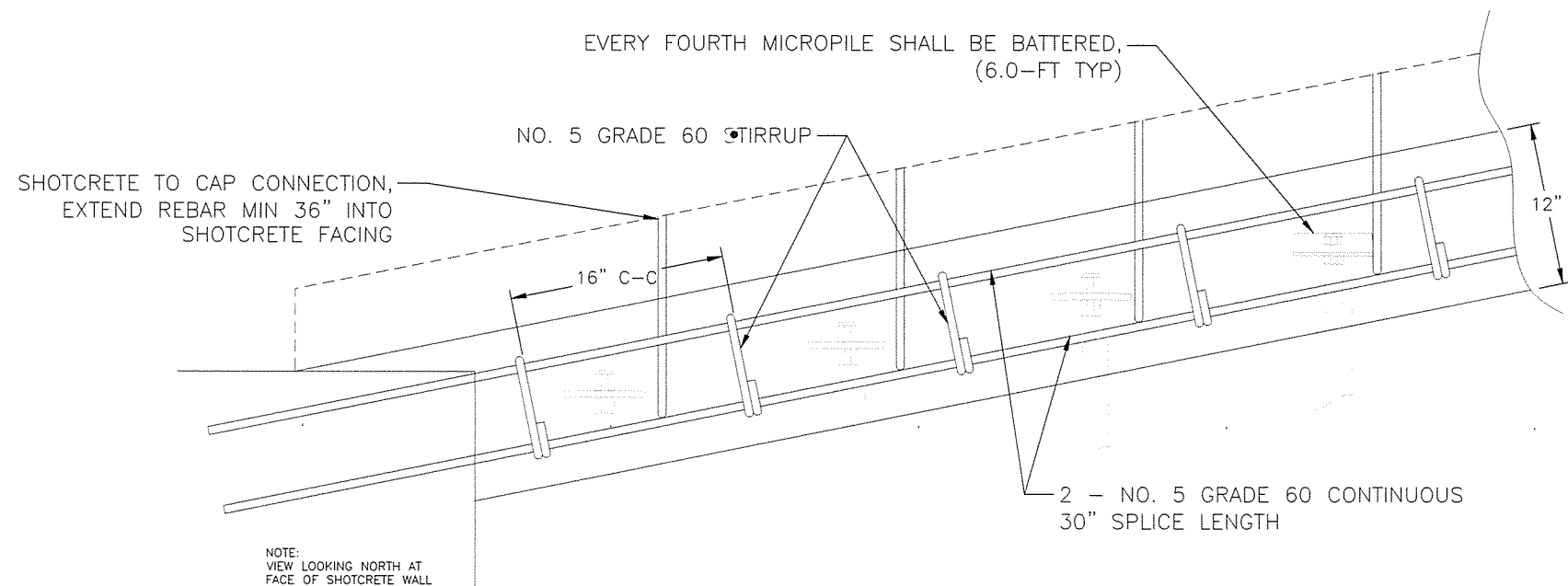

C MICROPILES - SIDE VIEW
Not To Scale

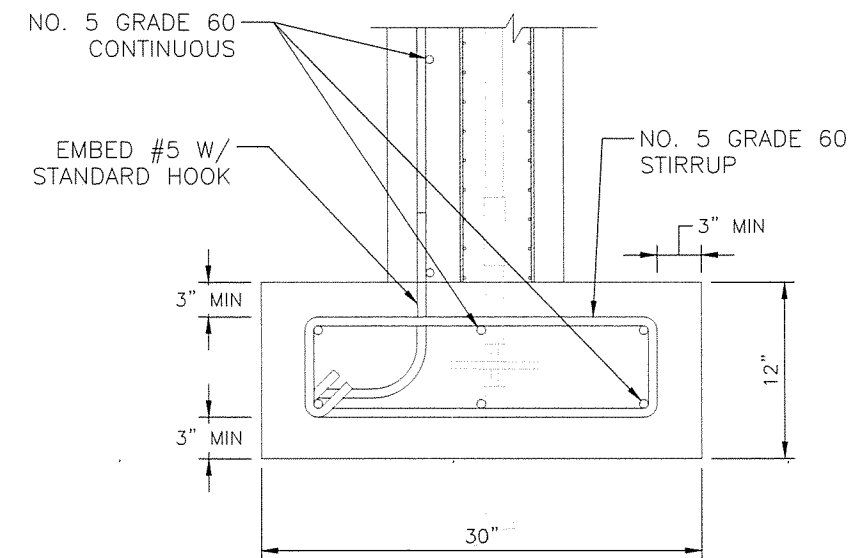

D REINFORCEMENT - END VIEW
Not To Scale

AS-BUILT
By: _____ Date: _____
R.C.E.: _____ Exp: _____

	MICROPILE CAP DETAILS	ENGINEER OF WORK	CITY APPROVED CHANGES	APP'D DATE	RECOMMENDED FOR APPROVAL	APPROVED FOR CONSTRUCTION	BENCH MARK	CITY OF SOLANA BEACH	ENGINEERING DEPARTMENT	DRAWING NO.
	Drawn By: JLW By: Patrick Poepsel, PE Date: _____	By: _____ Date: _____ By: _____ Date: _____	By: _____ Date: _____ By: Mohammad Sammat, City Engineer R.C.E.: 37146 Exp: 6/30/16	DESCRIPTION: _____ LOCATION: _____ ELEV: _____	DATUM: M.S.L.	GRADING PLANS FOR: LAS BRISAS CONDOMINIUMS	C-10 Sheet 10 of 13			

NOTE: SOIL BACKFILL THAT SUPPORTS PLANT GROWTH IS STANDARD ON THE BLUFF

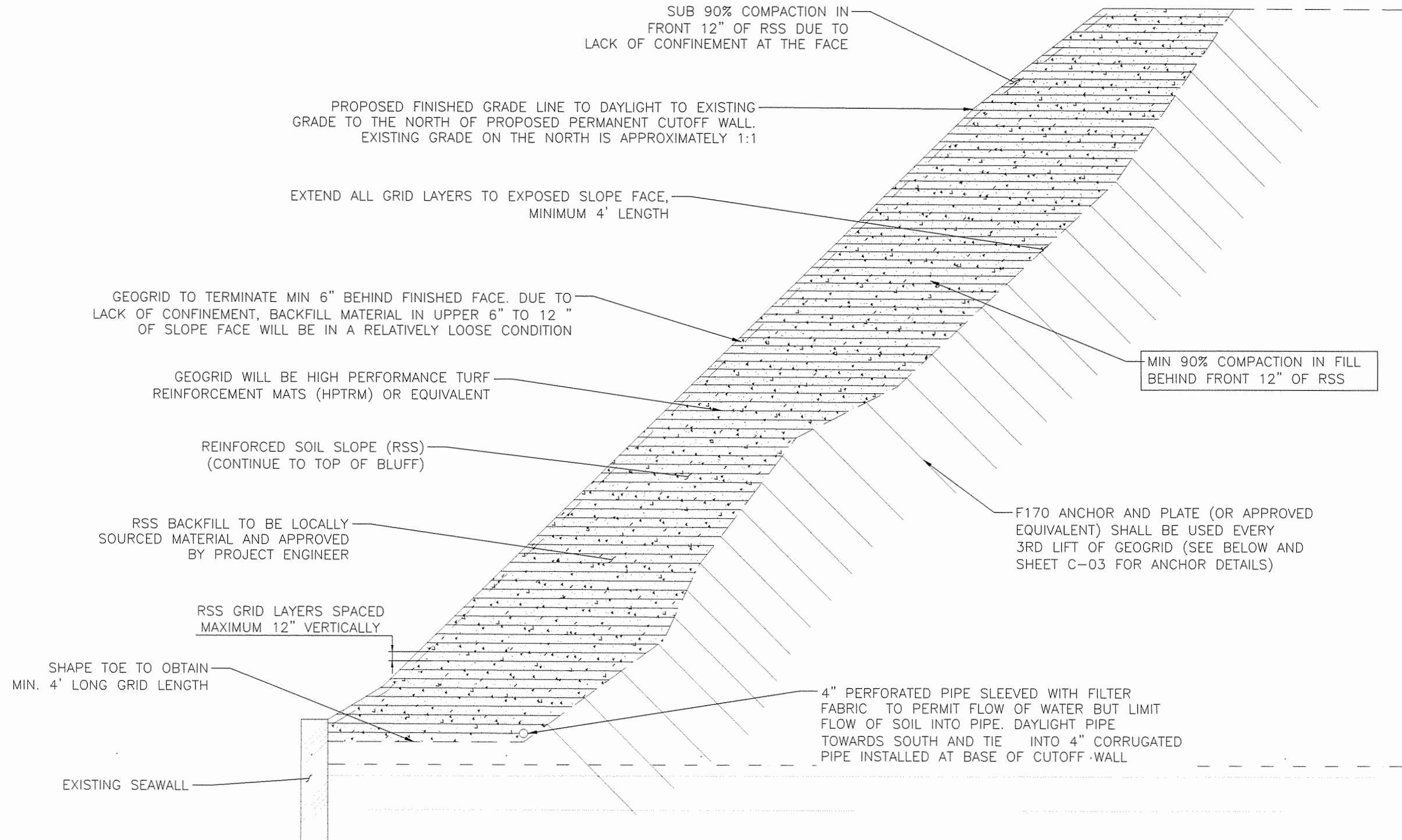

A REINFORCED SOIL SLOPE SECTION
Not To Scale

AS-BUILT
By: _____ Date: _____
R.C.E.: _____ Exp: _____

	SECTION VIEW - RSS SYSTEM	ENGINEER OF WORK	CITY APPROVED CHANGES	APP'D DATE	RECOMMENDED FOR APPROVAL	APPROVED FOR CONSTRUCTION	BENCH MARK	CITY OF SOLANA BEACH	ENGINEERING DEPARTMENT	DRAWING NO.
		JLW Drawn By	By: Patrick Poepsel, PE Date: _____		By: _____ Date: _____	By: Mohammad Sammak, City Engineer R.C.E.: 37146 Exp: 6/30/16		GRADING PLANS FOR: LAS BRISAS CONDOMINIUMS		C-11 Sheet 11 of 13

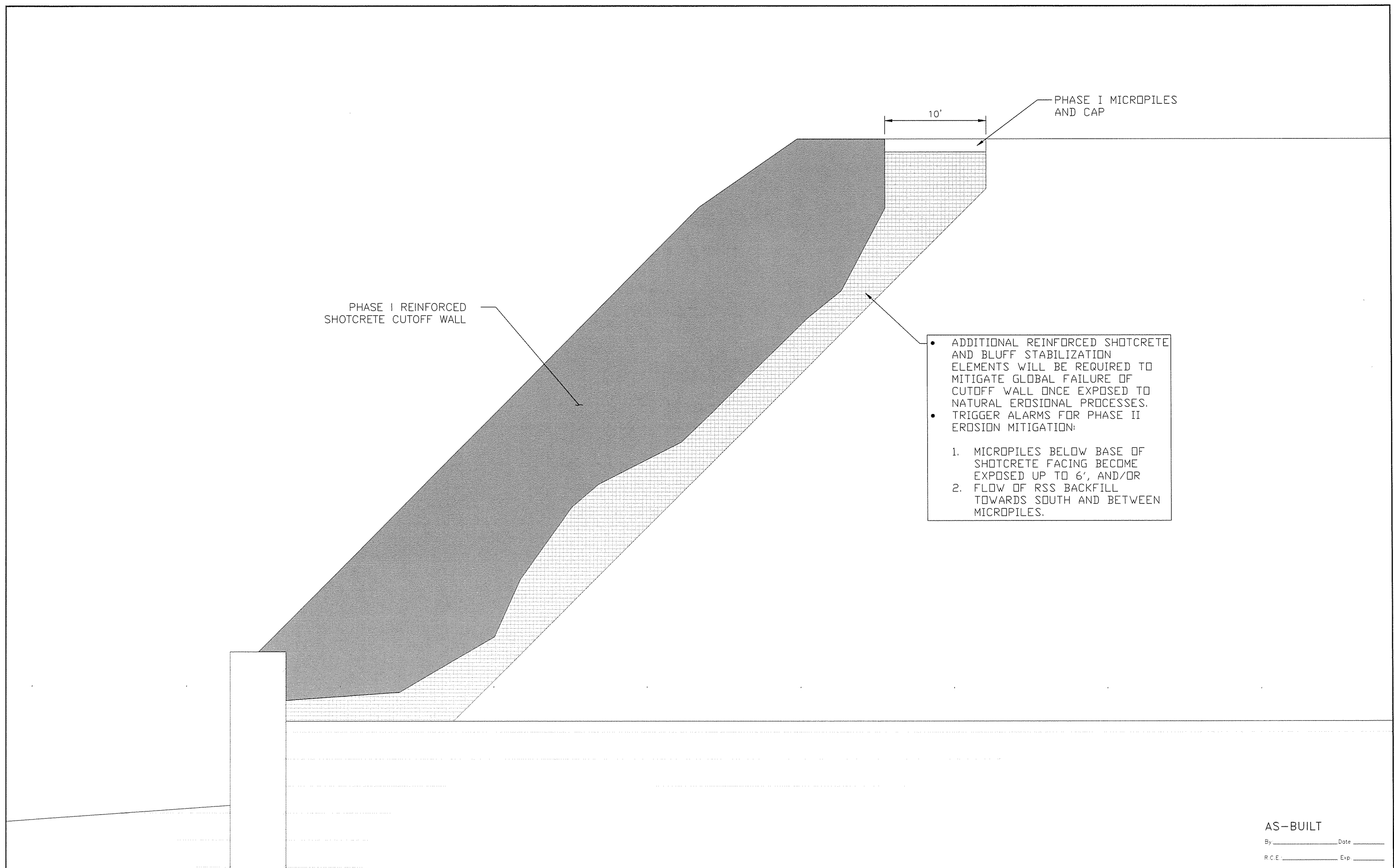

AS-BUILT
 By _____ Date _____
 R.C.E. _____ Exp. _____

	PHASE II MITIGATION SECTION	ENGINEER OF WORK	CITY APPROVED CHANGES	APP'D DATE	RECOMMENDED FOR APPROVAL	APPROVED FOR CONSTRUCTION	BENCH MARK	CITY OF SOLANA BEACH GRADING PLANS FOR LAS BRISAS CONDOMINIUMS	ENGINEERING DEPARTMENT	DRAWING NO
	Drawn By: JLW Date: _____	By: Patrick Poeppel, PE Date: _____	_____ _____ _____	_____ _____ _____	By: _____ Date: _____ By: _____ Date: _____	By: _____ Date: _____ R.C.E.: 37146 Exp: 6/30/16	_____ _____ _____		DATUM M.S.L.	Sheet 12 of 13



CITY OF SOLANA BEACH

635 SOUTH HIGHWAY 101 • SOLANA BEACH • CALIFORNIA 92075 • (858) 720-2400 • FAX (858) 755-1782

PROJECT EXTENSION APPLICATION

(Extension applying for: Conditional Use x Variance , Minor Exception ,
 Development Review Permit x, Director's Use Permit , Structure Development Permit)
(√ one or more that apply)

A. APPLICANT INFORMATION:

1. Project Address: 135 South Sierra Avenue (Las Brisas Condominiums)
2. Applicant's Name: Cain, Brian; Las Brisas HOA
(Last, First & Middle Initial or Company Name)
3. Applicant's Address: See Above Project Addresses
(Street, City, State & ZIP Code)
4. Applicant's Telephone: 619.997.1365 Fax: _____
5. Applicant's Email Address: caine123@gmail.com Cell Phone: 619.997.1365
6. Applicant's Agent: Bob Trettin, Principal Cell Phone: 858.603.1741
The Trettin Company
1195 La Moree Road, #18 Email: trettincompany@gmail.com
San Marcos, CA 92078

B. PLEASE COMPLETE THE FOLLOWING:

1. Provide a detailed factual description and explanation of the reasons why a building permit was not issued prior to the expiration of the original approval or preceding extension and the specific reason(s) the extension is necessary; the applicant's request for a specific time period for the extension.

The Las Brisas HOA's contractor reneged on their contract after plans had already been submitted for final plan check. The HOA Board has worked diligently to obtain another contractor and has recently signed a new contract for the construction of this much-needed project. However, do due to the fact that the previous contractor owned the plans, new plans needed to be drafted. Further, due to ongoing sloughages in the failure area, the new plans required some minor modifications from the original, approved plans.

The new plans are almost completed. It will now be necessary to obtain City of Solana Beach and California Coastal Commission findings that the new plans are in substantial conformance with the original plans, and then the plan check process can be reinitiated. These work elements cannot be completed prior to February 9, 2024, the date that the permit is set to expire if the building permit has not been issued.

2. A detailed description of the actions that will be taken during the specific requested extension period that justify the requested time period of the extension and that will result in the timely issuance of a building permit for the project before the extension expires.

As noted in response to Item #1, the applicants must obtain a set of revised plans, obtain findings of substantial conformance from the City of Solana Beach and the Coastal Commission, and then resubmit the plans for plan check and receipt of the project's building permit.

Based on past experience and current City & Coastal timelines, we believe this process can be completed within approximately five-six months. This will place the project in a ready-to-build position during the summer months. Because no work will take place from the public beach, the project could be initiated during the summer, dependent on the contractor's schedule.

3. A detailed timeline for the actions that will be taken during the requested extension period.

As noted in our response to Items #2, completion of substantial conformance findings and approval of the project's building permit will be somewhat determined by the City and Coastal Commission's processing timelines. As noted, however, we believe that these items can and will be completed along a timeline that will allow construction to commence in approximately six months.

The applicants are requesting a 12-month extension just to be safe and avoid needing to return for a further extension if any circumstances further delay building permit issuance beyond the timeline estimate provided in this submittal.

(Please attach any additional relevant information supporting the extension)

Applicant Signature:  , Vice President

Date: 11/29/23

The Trettin Company
Community & Government Relations / Project Development

November 30, 2023

TO: Corey Andrews, Principal Planner
City of Solana Beach

FROM: Bob Trettin, Principal
The Trettin Company
(Project Agent: Las Brisas HOA)

RE: Application For Extension of CUP 17-17-27 (Council Resolution #2022-013)

The attached application is a request for a 12 month extension of CUP 17-17-27, which encompasses a 60' long lateral pipe-pile retention wall along the southern boundary of Las Brisas Condominiums.

The basis for the extension, as documented in the application, was the fact that Las Brisas's contracted design/build firm for this project reneged on their contract and backed out of the project one day prior to the on-site pre-construction meeting with city staff.

The Las Brisas HOA and both their civil and geotechnical consultants, consider this project to be an emergency. Therefore the HOA Board has been extraordinarily diligent in their attempts to find and retain the services of another qualified contractor.

A new contractor (an engineering design/build firm) has now been retained. Because the original engineering / construction firm retained ownership of the plans, it was also necessary for the Las Brisas Board to obtain new engineering plans. Small changes in the topography of the bluff due to ongoing sloughages in the failure area have also dictated that the new plans, once completed, will have some minor changes. This will result in the need to obtain both City of Solana Beach and Coastal Commission staff reviews and findings that the new plans are in substantial conformance to the original, approved plans. Plan check will then need to be reinitiated prior to approval and issuance of the project's building permits. These actions cannot all be accomplished prior to February 9, 2024, which is the date that the project's CUP approval will expire.

The Las Brisas HOA Board and all of the owners within the complex are greatly concerned that the failure continues to expand and the Board has done everything in its power to expedite this emergency repair project. The circumstances that have caused a delay could not have been anticipated and were beyond the Board's control.

We believe that the City Council can and should make the findings, as addressed below, that the application for extension warrants approval:

1. The applicant has completed both City and Coastal discretionary approvals, has previously entered into City plan check and provided the requisite deposits. Documentation that the applicant has pursued issuance of the building permit in a timely and diligent manner is clearly well-documented with city engineering staff.
2. Circumstances beyond the applicants' control, as outlined above and in the application, have prevented the applicant from obtaining the building permit prior to expiration of the 24 month period allowed in the approved CUP.

1195 La Moree Road, #18
Ph: (858) 603-1741

San Marcos, California 92078
e-mail: trettincompany@gmail.com

3. The application for the extension sets forth both a reasonable and substantial factual basis for the issuance of the extension.
4. There is a substantial factual basis to determine that the applicant will be able to perform the actions necessary to obtain issuance of a building permit prior to expiration of the requested extension. Prior to a Council hearing on this extension application, the applicant will have submitted new plans, have requested staff findings of substantial compliance with the original approved plans, and will likely have already re-submitted for plan check.
5. The 12 month duration of the extension is not longer than reasonably necessary to obtain issuance of the building permit. The time-line should actually be shorter, however, the applicant is requesting 12 months based on the unknown length of agency review timelines.
6. There have been no changes in the general plan, applicable specific plan, if any, zoning or character of the area within which the project is located that would cause the approved project to become inconsistent, incompatible or nonconforming therewith.
7. The granting of the extension shall not be detrimental to the public health, or welfare, or materially injurious to properties or improvements in the vicinity. Conversely, failure to grant the extension would result in significant ongoing damage to the Las Brisas property and, ultimately, to the western-most Las Brisas condominium building.

Thank you for your assistance in processing this request as expeditiously as possible.

Respectfully submitted,



BOB TRETTIN, Principal
The Trettin Company

cc: Brian Caine
Las Brisas HOA Board



STAFF REPORT CITY OF SOLANA BEACH

TO: Honorable Mayor and City Councilmembers
FROM: Alyssa Muto, City Manager
MEETING DATE: May 22, 2024
ORIGINATING DEPT: Community Development Department
SUBJECT: **Public Hearing – Request for a Development Review Permit (DRP) Modification for Maintenance and Repairs to the Existing Geogrid Reinforced Upper Bluff Restoration on the Coastal Bluff Below 255, 261, and 265 Pacific Avenue. (Applicants: Alamo Family Trust, Sivage Family Revocable Trust, and Bradley and Susan Stone, 255-265 Pacific Avenue Case No.: MOD24-002 Resolution 2024-061)**

BACKGROUND:

The Applicants, Antonio and Maria Alamo Family Trust, Sivage Family Revocable Trust, and Bradley and Susan Stone, are requesting a Development Review Permit (DRP) Modification for maintenance and repairs to the existing geogrid reinforced upper bluff restoration on the coastal bluff below 255, 261, and 265 Pacific Avenue. The repairs would include backfilling existing eroded gullies within the existing geogrid reinforced slope, installation of secondary geogrid in the backfill of the gully repair, installation of temporary irrigation on the upper bluff, and revegetation of the upper bluff with native container plants and hydroseeding. Vegetation shall be native, drought tolerant, salt tolerant, and noninvasive plant species. Access to the subject areas on the bluff would be taken from the top of the bluff from the backyards of the subject properties. No beach access would be necessary. The properties are located within the Medium Residential (MR) Zone and the Scaled Residential Overlay Zone (SROZ).

The issue before the Council is whether to approve, approve with conditions, or deny the Applicants' request for a modification as contained in Resolution 2024-061 (Attachment 1).

CITY COUNCIL ACTION:

DISCUSSION:

In 1998, the Applicants received City of Solana Beach approval of a Special Use Permit with the adoption of Resolution 1998-101 (Attachment 2) for the construction of a 352-foot-long seawall and geogrid reinforced upper bluff restoration for the coastal bluff below properties at 249-311 Pacific Avenue. In 1999, the California Coastal Commission (CCC) issued a Coastal Development Permit (CDP) 6-99-100 for the same project. Construction of the project was completed in 2000. Special condition No. 3 of the CDP required annual monitoring of the work completed with the CDP in order to require the applicant to submit a CDP modification within three months of any monitored need of maintenance or repair of the seawall or upper bluff restoration.

A monitoring survey conducted in 2013 indicated that maintenance and repair of the seawall was needed. The property owners submitted for and received approval of DRP 17-13-33 with the adoption of Resolution 2014-111 (Attachment 3) at a City Council Public Hearing on August 27, 2014. The CCC approved CDP No. 6-14-0437 for the maintenance and repairs of the existing seawall.

In August 2023, the Applicants' engineer prepared the attached monitoring report for the entire project site (Attachment 4) and noted the erosion gullies. They have recommended the repairs proposed with this modification as well as the landscaping for 255, 261, and 265 Pacific Avenue. The project plans have been provided in Attachment 5.

The Solana Beach Municipal Code (SBMC) section 17.68.040.B.1.i indicates that *“Any development on a coastal bluff top property or on the face or toe of a bluff for which a coastal development permit issued by the California Coastal Commission is presently required.”* The CCC has told the Applicants that a CDP will be required. The City has required a modification because the properties had previously received CUP approval for the upper bluff restoration and a DRP for maintenance and repairs.

Development Review Permit Compliance (SBMC Section 17.68.40):

The Council may approve, or conditionally approve, a DRP only if all of the findings listed below can be made. If the findings cannot be made, the Council shall deny the DRP. Resolution 2024-061 provides a full discussion of the findings.

1. The proposed development is consistent with the general plan and all applicable requirements of the zoning ordinance including special regulations, overlay zones, and specific plans.
2. The proposed development complies with the development review criteria.
3. All required permits and approvals issued by the city, including variances, conditional use permits, comprehensive sign plans, and coastal development permits have been obtained prior to or concurrently with the development review permit.
4. If the development project also requires a permit or approval to be issued by a state or federal agency, the city council may conditionally approve the

development review permit upon the Applicants obtaining the required permit or approval from the other agency.

DRP Finding #1

General Plan Consistency

The General Plan designates the property as Medium Density Residential and is intended for multi-family residential development at a maximum density of 5-7 dwelling units per acre. Development in the immediate neighborhood consists of single-family residential development. The proposed development could also be found to be consistent with the objectives of the General Plan as it encourages the development and maintenance of healthy residential neighborhoods, the stability of transitional neighborhoods, and the rehabilitation of deteriorated neighborhoods.

Local Coastal Plan/Land Use Plan Consistency

The City Council adopted an LCP/LUP on February 27, 2013 (amended and certified on June 11, 2014). Although the LUP has been certified by the California Coastal Commission, the Local Implementation Plan (LIP) portion of the LCP has not yet been certified; as such, the provisions of the LUP are considered to be advisory rather than mandatory at this time.

The proposed project is subject to the following LUP policies:

Policy 4.27: Require all bluff property landscaping for new development to consist of native, non-invasive, drought-tolerant, fire-resistant, and salt-tolerant species.

Policy 4.54: Any bluff retention device shall be reasonably maintained and repaired by the bluff property owner on an “as needed” basis, at the bluff property owner’s expense, in accordance with the implementing ordinances and any permit issued by the City. Any authorized assessing entity in which the project lies shall ensure such payments are reimbursed to the City if the bluff property owner fails to perform such work and the City elects to do so, subject to mandatory reimbursement. However, in all cases, after inspection, it is apparent that repair and maintenance is necessary, including maintenance of the color of the structures to ensure a continued match with the surrounding native bluffs, the bluff property owner or assessing entity shall contact the City or CCC office to determine whether permits are necessary, and, if necessary, shall subsequently apply for a coastal development permit for the required maintenance.

Policy 4.55: To achieve a well maintained, aesthetically pleasing, and safer shoreline, coordination among property owners regarding maintenance and repair of all bluff retention devices is strongly encouraged. This may also result in cost savings through the realization of economies of scale to achieve these goals by coordination through an assessing entity. All bluff retention devices existing as of the date of certification of the LCP, to the extent they do not conform to the requirements of the LCP, shall be deemed non-conforming. A bluff property owner may elect to conform his/her/its bluff property or bluff retention device to the LCP at any time if the City finds that an existing bluff retention device that is required to protect existing principal structures in danger from erosion is

structurally unsound, is unsafe, or is materially jeopardizing contiguous private or public principal structures for which there is no other adequate and feasible solution, then the City may require reconstruction of the bluff retention device.

The City's third-party geotechnical engineer Universal Engineering Sciences (UES) reviewed the proposed modification plans and application information and determined that the proposed modification "is in substantial conformance with LCP policy 4.54, which states that "Any bluff retention device shall be reasonably maintained and repaired by the bluff property owner on an as-needed basis..." Their approval letter has been provided in Attachment 6.

Specific Plans and Special Overlays

The entire City of Solana Beach is located within the Coastal Zone. As a condition of project approval, the Applicants will be required to obtain a Coastal Development Permit prior to the issuance of grading permits.

Zoning Ordinance Consistency:

SBMC Section 17.20.010(C) specifies that the MR Zone is intended to provide for residential development in areas characterized primarily by detached single-family dwellings on older subdivided lots and two-family and multiple-family dwellings within newer, large lot, planned developments.

DRP Finding #2

The development review criteria topics referenced in DRP Finding #2 are listed below with further discussion as to how they relate to the proposed Project:

1. Relationship with Adjacent Land Uses
2. Building and Structure Placement
3. Landscaping
4. Roads, Pedestrian Walkways, Parking, and Storage Areas
5. Grading
6. Lighting
7. Usable Open Space

Relationship with Adjacent Land Uses:

Properties on the west side of Pacific Avenue are subject to specific development regulations due to their location along the coastal bluff. Many are protected by existing Bluff Retention Devices (BRD) that were constructed prior to the adoption of the City's Local Coastal Plan and Land Use Plan.

Building and Structure Placement:

No new buildings are proposed with the DRP modification.

Landscaping:

Once the eroded gullies have been repaired on the slope, temporary irrigation will be installed, and the upper bluff will be revegetated with container plants and hydroseed. All plant materials will be native, drought tolerant, salt tolerant, and noninvasive plant species. The proposed landscape plans were reviewed by the City's third-party landscape architect and are anticipated to provide ninety percent coverage within five years, or that percentage of ground cover demonstrated locally appropriate for a healthy stand of the particular native vegetation type chosen for the restoration.

Roads, Pedestrian Walkways, Parking, and Storage Areas:

No new roads, pedestrian walkways, parking, or storage areas are proposed with this DRP modification.

Grading:

There is no proposed change in topography with the proposed DRP modification. Backfilling of soil is proposed to fill eroded gullies within the existing geogrid reinforced slope.

Lighting:

No new lighting is proposed with this DRP modification.

Usable Open Space:

No additional open space is proposed with the DRP modification.

DRP Finding #3

No additional discretionary permits are required by the City for the proposed maintenance and repairs.

DRP Finding #4

If the City Council is able to make the required findings to approve the DRP modification, the Applicants will be required to obtain approval of a Coastal Development Permit from the CCC prior to issuance of a grading permit from the City.

Staff has prepared draft findings for approval of the project in the attached Resolution 2024-061 for Council's consideration based upon the information in this report. Additional project conditions from the Planning, Engineering and Fire Departments have been incorporated. In conclusion, the proposed project, as conditioned, could be found to be consistent with the Zoning regulations and the General Plan.

The Council may direct Staff to modify the Resolution to reflect the findings and conditions it deems appropriate as a result of the Public Hearing process. If the Council determines

the project is to be denied, Staff will prepare a Resolution of Denial for adoption at a subsequent Council meeting.

PUBLIC HEARING NOTICE:

Notice of the City Council Public Hearing was published in the San Diego Union Tribune more than 10 days prior to the public hearing. The same public notice was mailed to property owners and occupants within 300 feet of the proposed project site, more than 10 days prior to the planned Public Hearing date of May 22, 2024. Staff has not received any emails, letters or calls in support or opposition of the proposed modification as of the date this report was written.

CEQA COMPLIANCE:

The project is exempt from the California Environmental Quality Act (CEQA) pursuant to Section 15301 of the State CEQA Guidelines. Class 1 exemptions consist of the operation, repair, maintenance, permitting, leasing, licensing, or minor alteration of existing private structures involving negligible or no expansion of existing or former use. The proposed project would repair the existing upper bluff geogrid slope and re-vegetate the upper bluff after the original vegetation failed. There will be no expansion from the original approval.

FISCAL IMPACT: N/A

WORK PLAN: N/A

OPTIONS:

- Approve the proposed modification by adopting Resolution 2024-061;
- Approve modification by adopting Resolution 2024-061 with changes as deemed appropriate by City Council; or,
- Deny the request to amend the project and direct Staff to bring back a Resolution of denial to a later City Council meeting date.

DEPARTMENT RECOMMENDATION:

The proposed project meets the minimum objective requirements under the SBMC, is consistent with the General Plan and may be found, as conditioned, to meet the discretionary findings to approve a modification to the approved CUP. Therefore, Staff recommends that the City Council:

1. Conduct the Public Hearing: Open the Public Hearing, Report Council disclosures, Receive public testimony, Close the Public Hearing.
2. Find the project exempt from the California Environmental Quality Act.
3. If the City Council makes the requisite findings and approves the project, adopt Resolution 2024-061 conditionally approving a modification to the CUP for the

backfilling of existing eroded gullies within the existing geogrid reinforced slope, installation of secondary geogrid in the backfill of the gully repair, installation of temporary irrigation, and revegetation of the upper bluff with native container plants and hydroseeding on the coastal bluff below 255, 261, and 265 Pacific Avenue, Solana Beach.

CITY MANAGER'S RECOMMENDATION:

Approve Department Recommendation



Alyssa Muto, City Manager

Attachments:

1. Resolution 2024-061
2. Resolution 1998-101
3. Resolution 2014-111
4. Monitoring Report
5. Proposed Project Plans
6. Geotechnical Review

RESOLUTION 2024-061

A RESOLUTION OF THE CITY COUNCIL OF THE CITY OF SOLANA BEACH, CALIFORNIA, CONDITIONALLY APPROVING A DEVELOPMENT REVIEW PERMIT (DRP) MODIFICATION FOR MAINTENANCE AND REPAIRS TO THE EXISTING GEOGRID REINFORCED UPPER BLUFF RESTORATION ON THE COASTAL BLUFF BELOW 255, 261, AND 265 PACIFIC AVENUE, SOLANA BEACH.

**APPLICANTS: Antonio and Maria Alamo Family Trust,
Sivage Family Revocable Trust, and
Bradley and Susan Stone**

CASE NO.: MOD24-002

WHEREAS, Antonio and Maria Alamo Family Trust, Sivage Family Revocable Trust, and Bradley and Susan Stone (hereinafter referred to as “Applicants”), have submitted an application for a Development Review Permit (DRP) Modification pursuant to Title 17 (Zoning) of the Solana Beach Municipal Code (SBMC); and

WHEREAS, the Public Hearing was conducted pursuant to the provisions of Solana Beach Municipal Code Section 17.72.030; and

WHEREAS, at the Public Hearing on May 22, 2024, the City Council received and considered evidence concerning the proposed application; and

WHEREAS, the Public Hearing was conducted pursuant to the provisions of Solana Beach Municipal Code Section 17.72.030; and

WHEREAS, the City Council found the application request exempt from the California Environmental Quality Act pursuant to Section 15301 of the State CEQA Guidelines; and

WHEREAS, this decision is based upon the evidence presented at the Hearing, and any information the City Council gathered by viewing the site and the area as disclosed at the hearing.

NOW THEREFORE, the City Council of the City of Solana Beach, California, does resolve as follows:

- I. That the foregoing recitations are true and correct.
- II. That the request for a DRP Modification for maintenance and repairs to the existing geogrid reinforced upper bluff restoration on the coastal bluff below 255, 261, and 265 Pacific Avenue including backfilling existing eroded gullies within the existing geogrid reinforced slope, installation of secondary geogrid in the backfill of the gully repair, installation of temporary irrigation on the upper bluff, and revegetation of the upper bluff with native container plants and hydroseeding is conditionally approved based upon the following Findings and subject to the following Conditions:

III. FINDINGS

- A. In accordance with Section 17.68.040 (Development Review Permit) of the City of Solana Beach Municipal Code, the City Council finds the following:
- I. *The proposed project is consistent with the General Plan and all applicable requirements of SBMC Title 17 (Zoning Ordinance), including special regulations, overlay zones and specific plans.*

General Plan Consistency

The General Plan designates the property as Medium Density Residential and is intended for multi-family residential development at a maximum density of 5-7 dwelling units per acre. Development in the immediate neighborhood consists of single-family residential development. The proposed development could also be found to be consistent with the objectives of the General Plan as it encourages the development and maintenance of healthy residential neighborhoods, the stability of transitional neighborhoods, and the rehabilitation of deteriorated neighborhoods.

Local Coastal Plan/Land Use Plan Consistency

The City Council adopted an LCP/LUP on February 27, 2013 (amended and certified on June 11, 2014). Although the LUP has been certified by the California Coastal Commission, the Local Implementation Plan (LIP) portion of the LCP has not yet been certified; as such, the provisions of the LUP are considered to be advisory rather than mandatory at this time.

The proposed project is subject to the following LUP policies:

Policy 4.27: Require all bluff property landscaping for new development to consist of native, non-invasive, drought-tolerant, fire-resistant, and salt-tolerant species.

Policy 4.54: Any bluff retention device shall be reasonably maintained and repaired by the bluff property owner on an “as needed” basis, at the bluff property owner’s expense, in accordance with the implementing ordinances and any permit issued by the City. Any authorized assessing entity in which the project lies shall ensure such payments are reimbursed to the City if the bluff property owner fails to perform such work and the City elects to do so, subject to mandatory reimbursement. However, in all cases, after inspection, it is apparent that repair and maintenance is necessary, including maintenance of the color of the structures to ensure a continued match with the surrounding native

bluffs, the bluff property owner or assessing entity shall contact the City or CCC office to determine whether permits are necessary, and, if necessary, shall subsequently apply for a coastal development permit for the required maintenance.

Policy 4.55: To achieve a well maintained, aesthetically pleasing, and safer shoreline, coordination among property owners regarding maintenance and repair of all bluff retention devices is strongly encouraged. This may also result in cost savings through the realization of economies of scale to achieve these goals by coordination through an assessing entity. All bluff retention devices existing as of the date of certification of the LCP, to the extent they do not conform to the requirements of the LCP, shall be deemed non-conforming. A bluff property owner may elect to conform his/her/its bluff property or bluff retention device to the LCP at any time if the City finds that an existing bluff retention device that is required to protect existing principal structures in danger from erosion is structurally unsound, is unsafe, or is materially jeopardizing contiguous private or public principal structures for which there is no other adequate and feasible solution, then the City may require reconstruction of the bluff retention device.

The City's third-party geotechnical engineer Universal Engineering Sciences (UES) reviewed the proposed modification plans and application information and determined that the proposed modification "is in substantial conformance with LCP policy 4.54, which states that "Any bluff retention device shall be reasonably maintained and repaired by the bluff property owner on an as-needed basis..." Their approval letter has been provided in attachment 5.

Specific Plans and Special Overlays

The entire City of Solana Beach is located within the Coastal Zone. As a condition of project approval, the Applicants are required to obtain a Coastal Development Permit prior to the issuance of grading permits.

Zoning Ordinance Consistency:

SBMC Section 17.20.010(C) specifies that the MR Zone is intended to provide for residential development in areas characterized primarily by detached single-family dwellings on older subdivided lots and two-family and multiple-family dwellings within newer, large lot, planned developments.

II. *The proposed development complies with the following development review criteria set forth in Solana Beach Municipal Code Section 17.68.040.F:*

- a. *Relationship with Adjacent Land Uses: The development shall be designed in a manner compatible with and complementary to existing development in the immediate vicinity of the project site and the surrounding neighborhood. The development as proposed shall also be compatible in scale, apparent bulk, and massing with such existing development in the surrounding neighborhood. Site planning on or near the perimeter of the development shall give consideration to the protection of surrounding areas from potential adverse effects.*

Properties on the west side of Pacific Avenue are subject to specific development regulations due to their location along the coastal bluff. Many are protected by existing Bluff Retention Devices (BRD) that were constructed prior to the adoption of the City's Local Coastal Plan and Land Use Plan.

- b. *Building and Structure Placement: Buildings and structures shall be sited and designed to minimize adverse impacts on the surrounding properties and designed in a manner which visually and functionally enhance their intended use and complement existing site topography. Multi-family residential buildings shall be sited to avoid crowding and to allow for a functional use of the space between buildings.*

No new buildings are proposed with the DRP modification.

- c. *Landscaping: The removal of significant native vegetation shall be minimized. Replacement vegetation and landscaping shall be compatible with the vegetation of the surrounding area. To the maximum extent practicable, landscaping and plantings shall be used to screen parking areas, storage areas, access roads, and other service uses of the site. Trees and other large plantings shall not obstruct significant views when installed or at maturity. Drought tolerant plant materials and water conserving irrigation systems shall be incorporated into all landscaping plans.*

Once the eroded gullies have been repaired on the slope, temporary irrigation will be installed, and the upper bluff will be revegetated with container plants and hydroseed. All plant materials will be native, drought tolerant, salt tolerant, and noninvasive plant species. The proposed landscape plans were reviewed by the City's third-party landscape architect and are anticipated to provide ninety percent coverage within five years,

or that percentage of ground cover demonstrated locally appropriate for a healthy stand of the particular native vegetation type chosen for the restoration.

- d. *Roads, Pedestrian Walkways, Parking and Storage Areas: Any development involving more than one building or structure shall provide common access roads and pedestrian walkways. Parking and outside storage areas, where permitted, shall be screened from view, to the extent feasible, by existing topography, by the placement of buildings and structures, or by landscaping and plantings.*

No new roads, pedestrian walkways, parking, or storage areas are proposed with this DRP modification.

- e. *Grading: To the extent feasible, natural topography and scenic features of the site shall be retained and incorporated into the proposed development. Any grading or earth-moving operations in connection with the proposed development shall be planned and executed so as to blend with the existing terrain both on and adjacent to the site. Existing exposed or disturbed slopes shall be landscaped with native or naturalized non-native vegetation and existing erosion problems shall be corrected.*

There is no proposed change in topography with the proposed DRP modification. Backfilling of soil is proposed to fill eroded gullies within the existing geogrid reinforced slope.

- f. *Lighting: Light fixtures for walkways, parking areas, driveways, and other facilities shall be provided in sufficient number and at proper locations to assure safe and convenient nighttime use. All light fixtures shall be appropriately shielded so that no light or glare is transmitted or reflected in such concentrated quantities or intensities as to be detrimental to the surrounding areas per SBMC 17.60.060 (Exterior Lighting Regulations).*

No new lighting is proposed with this DRP modification.

- g. *Usable Open Space: Recreational facilities proposed within required usable open space shall be located and designed to maintain essential open space values.*

No additional open space is proposed with the DRP modification.

- III. *All required permits and approvals including variances, conditional use permits, comprehensive sign plans, and coastal development permits*

have been obtained prior to or concurrently with the development review permit.

No additional discretionary permits are required by the City for the proposed maintenance and repairs.

- IV. *If the development project also requires a permit or approval to be issued by a state or federal agency, the city council may conditionally approve the development review permit upon the Applicants obtaining the required permit or approval from the other agency.*

The Applicants are required to obtain approval of a Coastal Development Permit from the CCC prior to issuance of a grading permit from the City.

V. CONDITIONS:

Prior to use or development of the property in reliance on this permit, the Applicants shall provide for and adhere to the following conditions:

A. Community Development Department Conditions:

- I. Grading Permit plans must be in substantial conformance with the plans presented to the City Council on May 22, 2024, and located in the project file with a submittal date of March 26, 2024.
- II. The Applicants shall obtain required California Coastal Commission (CCC) approval of a Coastal Development Permit, Waiver or Exemption as determined necessary by the CCC, prior to the issuance of a grading or building permit.
- III. The Applicants shall provide a full Landscape Documentation Package in compliance with SBMC Chapter 17.56 and in substantial conformance with the approved landscape plan included in the project plans presented to the City Council on May 22, 2024, prior to Grading Permit issuance and consistent with the building construction plan. The landscape plan and installation will be reviewed and inspected by the City's third-party landscape professional. Prior to final inspection of the building permit (and occupancy), the landscape installation shall pass inspection by the City's third-party landscape professional.
- IV. The Applicants shall submit landscape security in a form prescribed by the City Engineer in addition to the grading security. The landscape security deposit shall be released after the landscape has been established and the temporary irrigation has been removed a maximum of 24-months from installation.
- V. All plant material shall be native, non-invasive, drought-tolerant, fire-

resistant, and salt-tolerant species.

- VI. The temporary irrigation system shall include a redundant valve control/shut off valves to prevent any irrigation system leaks or failures.
 - VII. All landscape plantings shall be in a good growing condition throughout the life of the project and whenever necessary, shall be replaced with new plant materials to ensure compliance with the landscape plan.
 - VIII. The temporary irrigation shall be inspected after 12 months following the planting to ensure planting success and to verify that irrigation is still required. A report prepared by the licensed landscape architect of record detailing the status of the vegetation, an assessment of the condition of the temporary irrigation system and a recommendation on whether the temporary irrigation is still necessary shall be provided to the City.
 - IX. The temporary irrigation system may remain active and in place up to a maximum of 24 months at the approval of the City and shall be removed once plants have become established.
 - X. Construction vehicles shall be parked on the subject property at all times when feasible. If construction activity prohibits parking on the subject property, the Applicants shall ensure construction vehicles are parked in such a way to allow sufficient vehicular access on Pacific Avenue and minimize impact to the surrounding neighbors.
- B. Fire Department Conditions:
- I. N/A
- C. Engineering Department Conditions:
- I. Obtain required California Coastal Commission Permits prior to the issuance of any structure and grading permits or present evidence that an emergency waiver has been granted.
 - II. The project shall be designed and shall provide appropriate data to confirm the submitted design to the satisfaction of the City Engineer. This shall include, but is not limited to, a geotechnical report.
 - III. If access from the beach is required, the property owners shall post securities to guarantee proper care and use of the Fletcher Cove Beach Access Ramp. No construction materials to be off-loaded on the ramp, at the end of the ramp or any public property including streets and

Fletcher Cove Park. No washing of equipment shall occur unless a containment system is properly utilized.

- IV. For all projects on which equipment is driven on the Fletcher Cove Beach Access Ramp, the ramp and adjacent parking lot must be swept daily to remove sand that has been tracked onto the ramp and parking lot. At least once a week, the access ramp and parking lot must be swept with a street sweeper that is capable of cleaning the streets and parking lots of paper, glass, dirt, silt, sand, rocks, litter and miscellaneous debris. The street sweeper shall be equipped with dual gutter brooms, and vacuum equipment may be used. If any sand is tracked outside the parking lot, these areas (including city streets) must also be cleaned weekly with a street sweeper.
- V. The property owners shall pay all inspection and plan check fees as required by the City.
- VI. Plans and specifications for the project shall be approved by the City Engineer in addition to approvals from the Director of Planning as may be required and shall substantially conform to the plans submitted by the Applicants. All bluff stabilization devices shall produce a natural appearing bluff to the satisfaction of the City Engineer and the Community development director. Project implementation shall provide a final product mimicking a naturally appearing bluff in terms of colors, textures, forms and angles.
- VII. A grading/drainage plan shall be prepared by a registered civil engineer in accordance with the current Grading Ordinance and be submitted to the City Engineer for approval and permit issuance. Prior to issuance of the engineering permit, the contractor shall provide a plan for the method and means by which the workers will be performing the bluff repair and revegetation activities. A clear zone along the beach directly below the project site shall be designated to the satisfaction of the City Engineer.
- VIII. The Applicants shall post with the City a Performance Bond equal to the full amount of the work to be completed to guarantee that once started, construction will be completed per approved plans.
- IX. The Applicants shall submit a Certificate of Insurance naming the City of Solana Beach as an additional insured in the amount of \$2,000,000 on a policy of general liability insurance issued by an insurance company licensed to do business in California, and meeting the requirements established by City Council resolution for insurance companies doing business with the City, covering injuries to persons and property during the construction period.

- X. If access from the beach is required, the Applicants shall obtain a Special Use (Marine Safety) Permit specifying conditions governing use of the Fletcher Cove Beach Access Ramp, and entry upon and use of areas of the public beach for construction equipment and vehicles. Evidence of permit issuance shall be submitted to the City Engineer before issuance of the permit for the project.
- XI. If access from the beach is required, the Applicants shall have on file evidence from the Marine Safety Department and the City Engineer that arrangements have been made to satisfy the following criteria:
- a. Prior to usage of the Solana Beach Fletcher Cove ramp or parking lot, a cash deposit, bond or other secured agreement to cover the following impact charges shall be deposited:
 - i. A six-dollar (\$6.00) per round trip vehicle charge for all construction related vehicles using the ramp.
 - ii. A three-dollar (\$3.00) per ton fee, or less if approved by the City Council, based on the estimated weight of the vehicle and load for all vehicles in excess of $\frac{3}{4}$ ton capacity, excluding any vehicles solely transporting beach grade replenishment sand.
 - iii. A thirty-one dollar (\$31) per day charge for the first 30 days escalating to fifty-seven dollars (\$57) per day for the 31st and subsequent days charge shall be collected to encourage a timely completion of all projects, unless otherwise modified for good cause by the City Council or City Manager.
 - iv. Any damage caused to the Solana Beach Fletcher Cove Ramp and parking lot.
 - b. For projects using the Solana Beach Fletcher Cove Ramp, at least one City of Solana Beach Lifeguard shall be contracted, at the Applicants' expense, through the Captain of Marine Safety, to monitor all activities in order to insure full compliance with the conditions of this permit. The lifeguard(s) shall be on duty at all times when any construction activity takes place. Additional lifeguards may be required at the discretion of the Captain of Marine Safety. In addition to the lifeguard staffing cost, the Applicant shall also pay a Marine Safety equipment use fee of four-dollar and sixty-four cents (\$4.64) per hour, based on the number of the number of hours the lifeguards are contracted for the project.
 - c. If construction access is from Fletcher Cove Park, precautions shall be taken to avoid damage to the beach access ramp during construction and repairs. If damage to the ramp occurs, it shall be

repaired to a condition equivalent to the condition at the start of construction activity to the satisfaction of the City of Solana Beach City Engineer. All City owned work areas including Fletcher Cove Park and access ramp shall be videotaped prior to the commencement of the project. The videotape shall establish the “as-is” condition. In any areas missed by the videotape, the City Engineer will determine “as-is” condition.

If access is from the State Park at the north end of Solana Beach, precautions shall be taken to avoid damage to the hard layer of fossiliferous sandstone that forms the beach surface at the north end of the coastal bluffs. Such access may necessitate State approval. Proof of State approval shall be provided to the City Engineer before construction begins.

- XII. Beach quality sand from the excavation for the proposed project shall be deposited and spread on the beach in front of this site unless unique and/or inappropriate conditions are encountered. The Applicants should reference this condition to other permitting agencies.
- XIII. An encroachment permit from the Engineering Department is required if a crane, construction materials, etc. are envisioned to be stationed in the public right of way. The City does not guarantee that an encroachment permit will be approved.
- XIV. A qualified, licensed, and insured contractor shall perform all required work as outlined by certified/registered engineering geologist or Registered Civil Engineer on the construction plans. Special and general notes on said plans shall be followed to the satisfaction of the City Engineer or his designee.
- XV. Lateral pedestrian and Marine Safety vehicular access through the construction area, shall be provided past the site at all times, subject to high tides and safety issues. A 30-foot wide safety/construction work zone shall be provided during work hours to separate the work zone from the open public beach.
- XVI. No construction activities may occur on the beach during the busier recreational season, which is defined as the period between Memorial Day and Labor Day of any year. The contractor shall obtain approval from the City of Solana Beach Engineering and Marine Safety Departments regarding the use and timing of the Fletcher Cove parking lot and beach access ramp for all construction related access, staging and parking issues if such use becomes required.
- XVII. Pursuant to SBMC Section 7.34.100, Construction hours are limited to 7:00 a.m. to 7:00 p.m., Monday through Friday, and 8:00 a.m. to 7:00

p.m. on Saturday. No work is allowed on Sunday or holidays unless specifically approved pursuant to SBMC Section 7.34.100.B. Engines shall not be started, no construction-related materials shall be moved, or any other construction-related activities occur outside these hours. Work is not permitted on the beach on Saturdays without the written approval of the City Manager.

Prior to Final Inspection of the project, the Applicants shall:

- XVIII. Submit certification to the City Engineer from the Geotechnical Engineer and the Civil Engineer of Record for the project that they have inspected the project and certify that it was constructed per the approved plan, specifying the date of the plan.
- XIX. The Applicants and/or contractor shall repair any damage caused to the Solana Beach property and facilities, including but not limited to, Fletcher Cove Ramp and parking lot to the satisfaction of the City Engineer.

The Applicants shall provide for and adhere to the following Conditions:

- XX. All development on the site shall substantially conform to the final Conditional Use Permit Plan approved by the City Council.
- XXI. The property owner shall be responsible to immediately remove, in perpetuity, any graffiti or other markings should they appear on the project exterior face. If erosion exposes the steel rebar, the Applicants or their successor in interest shall arrange to apply a sculptor-coat of concrete over the exposed steel to match the natural bluff. The property owner shall be responsible for the removal of the structure or any portion thereof.
- XXII. If requested by the City Manager or his designee, the property owner or their successor in interest shall install and maintain signage about unstable bluffs fronting their property.
- XXIII. The Applicants shall provide "As-Built" plans and all certifications required to the City before the City will release the performance bond as indicated in condition VIII.

D. City Council Conditions:

I.

IV. ENFORCEMENT

Pursuant to SBMC 17.72.120(B) failure to satisfy any and all of the above-

mentioned conditions of approval is subject to the imposition of penalties as set forth in SBMC Chapters 1.1.6 and 1.18 in addition to any applicable revocation proceedings.

V. EXPIRATION

The Development Review Permit for the project shall expire 24 months from the date of this Resolution, unless the Applicants has obtained building permits and has commenced construction prior to that date, and diligently pursued construction to completion. An extension of the application may be granted by the City Council according to SBMC 17.72.110.

VI. INDEMNIFICATION AGREEMENT

The Applicants shall defend, indemnify, and hold harmless the City, its agents, officers, and employees from any and all claims, actions, proceedings, damages, judgments, or costs, including attorney's fees, against the City or its agents, officers, or employees, relating to the issuance of this permit including, but not limited to, any action to attack, set aside, void, challenge, or annul this development approval and any environmental document or decision. The City will promptly notify the Applicants of any claim, action, or proceeding. The City may elect to conduct its own defense, participate in its own defense, or obtain independent legal counsel in defense of any claim related to this indemnification. In the event of such election, the Applicants shall pay all of the costs related thereto, including without limitation reasonable attorney's fees and costs. In the event of a disagreement between the City and Applicants regarding litigation issues, the City shall have the authority to control the litigation and make litigation related decisions, including, but not limited to, settlement or other disposition of the matter. However, the Applicants shall not be required to pay or perform any settlement unless such settlement is approved by the Applicants.

NOTICE TO APPLICANTS: Pursuant to Government Code Section 66020, you are hereby notified that the 90-day period to protest the imposition of the fees, dedications, reservations or other exactions described in this resolution commences on the effective date of this resolution. To protest the imposition of any fee, dedications, reservations or other exactions described in this resolution you must comply with the provisions of Government Code Section 66020. Generally the resolution is effective upon expiration of the tenth day following the date of adoption of this resolution, unless the resolution is appealed or called for review as provided in the Solana Beach Zoning Ordinance.

PASSED AND ADOPTED at a regular meeting of the City Council of the City of Solana Beach, California, held on the 22nd day of May, 2024, by the following vote:

AYES: Councilmembers –
NOES: Councilmembers –

ABSENT: Councilmembers –
ABSTAIN: Councilmembers –

LESA HEEBNER, Mayor

APPROVED AS TO FORM:

ATTEST:

JOHANNA N. CANLAS, City Attorney

ANGELA IVEY, City Clerk

RESOLUTION NO. 98-101

A RESOLUTION OF THE CITY COUNCIL OF THE CITY OF SOLANA BEACH, CALIFORNIA APPROVING A SPECIAL USE PERMIT FOR A 352 FOOT LONG SEAWALL AND GEOGRID REINFORCED UPPER SLOPE FOR PROPERTY LOCATED ON THE COASTAL BLUFF ADJACENT TO 249-311 PACIFIC AVENUE

**APPLICANT: BUZZ AND DIANA COLTON
CASE NO.: 17-98-25**

WHEREAS, Buzz and Diana Colton (hereinafter referred to as "Applicant") have requested the issuance of a Special Use Permit pursuant to Title 17 of the Solana Beach Municipal Code Section 17.62.080; and

WHEREAS, at the October 20, 1998 City Council meeting, direction was given to expedite this permit due to public health, safety and welfare issues associated with the extremely rapid coastal bluff erosion; and

WHEREAS, on November 9, 1998, the City Council held a duly noticed public hearing; and

WHEREAS, the City Council of the City of Solana Beach found on November 9, 1998, that the use of a sea wall and upper bluff retention structure was a specific action necessary to prevent an emergency and hence was exempt from CEQA pursuant to Section 15269(c) of the State CEQA Guidelines; and

WHEREAS, this decision is based upon the evidence presented at the Public Hearing on this matter; Oral Communications information presented during the October 20, and November 3, 1998 Council Meeting; the Special Use Permit application, any information the City Council gathered by viewing the site and the area as disclosed at the hearing;

NOW THEREFORE, the City Council of the City of Solana Beach, California does resolve as follows:

- 1. That the forgoing recitations are true and correct.**
- 2. That the project is exempt from CEQA as an emergency pursuant to Section 15269(c) of the State CEQA Guidelines.**
- 3. That the Special Use Permit for an approximately 352 foot long seawall and Geogrid reinforced upper slope is approved in substantial conformance with Attachment 1 based upon the following Findings and subject to the following Conditions.**

4. FINDINGS:

A. Pursuant to Section 17.62.080.A. of Title 17, Zoning, of the Solana Beach Municipal Code, the City Council finds that:

I. An existing significant structure is threatened with imminent danger or destruction because of bluff erosion which occurs naturally, or which results or arises from circumstances which are not within the control of the property owners, and it is reasonably foreseeable that without the shoreline defense structure the threatened structure on the site will suffer structural damage.

The existing structure(s) are threatened with imminent danger or destruction because of bluff erosion resulting from the lack of protective sand beaches that allowed destructive storm waves from last winter's El Nino storms to erode as much as 15 feet of the lower sea cliff, thereby undermining the upper terrace deposits and exposing the relatively clean sand at the base of this geologic unit. The property owner has no control over the conditions resulting in the danger. It is reasonably foreseeable that without the proposed shoreline improvements, the structure at 261 Pacific Avenue, along with its neighboring structures, will suffer structural damage.

The upper bluff is rapidly becoming undermined due to gentle breezes eroding the clean sands at the base of the terrace deposits. Continual loss of sand triggers upper-bluff failures totally unassociated with wave activity resulting in tens to hundreds of cubic yards of soil that will fall on the beach, creating a significant public hazard/nuisance that cannot be reasonably abated in another manner.

II. No other reasonably feasible method of stabilizing the coastal bluff will protect the existing structure, abate the nuisance or preserve the economically viable use of the property.

The slope is unstable and no other reasonably feasible methods exist for stabilizing the coastal bluff, for abating the nuisance, or for preserving the economically viable use of the property.

III. The property owner has taken reasonable steps to protect the property and significant structures by other means.

The property owner has taken reasonable steps to protect the property by utilizing proper drainage and respecting coastal bluff setbacks. There are no other steps to protect the property and/or the bluff-top structure by other means.

IV. The owners or prior owners did not create the necessity for the shoreline defense structure by unreasonably failing to implement generally accepted erosion and drainage control measures or by otherwise unreasonably acting or failing to act with respect to the property.

The project and location is 5+ feet above Pacific Avenue, with all site drainage draining to this public street. Neither the owners, nor prior owners, in any way adversely affected the stability of the clean sand lens.

V. The location, size, design and operation characteristics of the proposed shoreline defense structure will not adversely affect adjacent public or private property, natural resources, or public use of the beach.

The dimension of the structure is such that it places a maximum 2-1/2-foot-thick carved and colored, structural concrete skin on the existing face of the sea cliff, the location of which advance shoreward (by marine erosion) during last winter's El Niño storm season. In certain areas, the project will be located entirely on private property. In other areas, the wall will encroach on public properties to the minimum degree possible.

VI. The proposed shoreline defense structure will be:

- a. The minimum measure necessary to provide a reasonable level of protection;

The proposed project is the minimum measure necessary to protect the clean sands exposed in the vertical scarp at the base of the upper terrace deposits and to infill the upper-bluff failure in order to provide subadjacent lateral support to the bluff-top residences and remaining section of coastal bluff on either side of the failure.

- b. Construct and maintained to incorporate an earth-like appearance which will resemble as closely as possible the natural color and texture of the adjacent bluffs;

The project has been conditioned to incorporate an earth-like appearance which will resemble as closely as possible the natural color and texture of the adjacent bluffs.

- c. Constructed and maintained to reasonably conform to the natural form of the bluff;

The proposed project has been conditioned to reasonably conform to the natural form of the bluff in color, texture, and landscaping.

- d. **Placed at the most feasible land-ward location;**

The wall will be a maximum of 2-1/2 feet in thickness and constructed contiguous with the face of the bluff and thus at the most land-ward possible location.

- e. **Appropriately landscaped and maintained to blend in with the existing environment.**

The proposed project has been conditioned to be appropriately landscaped and maintained to blend in with the existing environment.

VII. The shoreline defense structure will be located entirely on private property or, if the structure will be located partially or entirely on public property or property subject to a public trust all required permits for construction or real property interests have been obtained, or will be obtained, from the appropriate public agency or agencies with jurisdiction and/or ownership.

The applicant / project is conditioned to obtain all necessary permits and approvals from the Federal, State and local agencies.

VIII. The construction of the structure and reconstruction of the bluff face, if any, will not result in a usable area at the top of the bluff larger than existed on January 3, 1991 or extend the bluff-top edge seaward more than 10 feet from the bluff-top edge as it existed on January 3, 1991 as shown on the ortho-photo map of the city dated January 3, 1991 and on file in the planning department.

There will be no seaward encroachment of the bluff-top beyond that which existed on January 3, 1991.

IX. The project as approved or conditionally approved will not adversely affect the public health, safety or welfare and will not unreasonably affect the public use of the beach. Encroachments into the public beach shall be mitigated to the satisfaction of the city council.

Any restrictions on the use of the beach will be temporary during construction. The project will benefit the public by placing 6,000 cubic yards of beach grade sand on the beach. The lack of a project may adversely affects the public health, safety and welfare of those using the beach.

B. Coastal Act (Public resources Code Section 30235). The proposed cliff retaining wall is required: (1) to protect the existing residence, which is uniquely in danger from the recent extensive upper bluff erosion, and (2) to protect the users of the public beach from the danger of falling rocks and earth due to further imminent erosion.

C. Pursuant to Government Code Section 865 to 867 (existing impending peril), an immunity will apply if the City has, on the basis of adequate evidence such as expert opinion or otherwise, found the existence of an impending peril; determined appropriate remedial action to halt, stabilize, or abate such impending peril; and has undertaken to implement such remedial action.

5. CONDITIONS:

A. Prior to obtaining any building or grading permits pursuant to this Special Use Permit, the Applicant shall:

I. Prepare, execute and record a declaration of restrictions on real property approved by the City Attorney whereby the applicant or the applicant's successors in interest to the property will construct and maintain the seawall/cliff retaining wall in accordance with Conditions C.III and C.IV of this approval and in a manner so as to accommodate the continual erosion of the natural cliffs, as necessary.

II. Obtain required California Coastal Commission Permits prior to the issuance of any structure and grading permits or present evidence that an emergency waiver has been granted.

III. Obtain any other permits or emergency waivers which may be required from State and Federal agencies including the State Lands Commission and the U.S. Army Corps of Engineers.

IV. Execute a waiver of all claims against the City of Solana Beach for future liability or damage resulting from permission to build as granted under this permit. Said waiver shall be acknowledged and recorded in the Office of the County Recorder.

V. Seawall key and tieback system shall be designed and shall provide appropriate data to confirm the submitted design to the satisfaction of the City Engineer.

VI. The property owner shall post securities to guarantee proper care and use of the Fletcher Cove ramp. No construction materials to be off-loaded on the ramp or at the end of the ramp.

VII. The property owners shall pay all inspection and plan check fees as required by the City.

VIII. Plans and specifications for the project shall be approved by the City Engineer in addition to approvals from the Director of Planning.

IX. A grading/drainage plan shall be prepared by a registered civil engineer in accordance with the current Grading Ordinance and be submitted to the City Engineer for approval and permit issuance.

X. Plans and specifications for the project shall be approved by the Planning Department prior to submittal to the Engineering Department.

XI. The Applicant shall post with the City a Performance Bond equal to the full amount of the work to be completed to guarantee that once started, construction will be completed per approved plans.

XII. The Applicant shall submit a Certificate of Insurance naming the City of Solana Beach as an additional insured in the amount of \$1,000,000 on a policy of general liability insurance issued by an insurance company licensed to do business in California, and meeting the requirements established by City Council resolution for insurance companies doing business with the City, covering injuries to persons and property during the construction period.

XIII. The Applicant shall obtain a Special Use Permit from the Captain of Marine Safety and City Engineer specifying the conditions governing use vehicles, use of the boat ramp, and entry upon and use of areas of the public beach for construction equipment and vehicles. Evidence of permit issuance shall be submitted to the City Engineer before issuance of the permit for the project.

XIV. The Applicant shall present evidence from the Captain of Marine Safety and City Engineer, City of Solana Beach, that arrangements have been made to satisfy the following criteria:

a. Prior to usage of the Solana Beach Fletcher Cove ramp or parking lot, a cash deposit, bond or other secured agreement to cover the following impact charges shall be deposited:

i. A five-dollar per round trip vehicle charge for all construction related vehicles using the ramp.

ii. A ten-dollar per ton fee based on the estimated weight of the vehicle and load for all vehicles in excess of ¾ ton capacity, excluding vehicles solely transporting the approximately 6,000 cubic yards of beach grade sand.

iii. A twenty-five dollar per day charge for the first week escalating the fifty dollars per day for the eighth and subsequent days charge shall be collected to encourage a timely completion of all projects.

iv. Any damage caused to the Solana Beach Fletcher Cove ramp and parking lot.

b. Two City of Solana Beach Lifeguards shall be contracted, at the Applicant's expense, through the Captain of Marine Safety to monitor all activities in order to insure full compliance with the conditions of this permit. These lifeguards shall be on duty at all times when any construction activity takes place.

c. If construction access is from Plaza Street, precautions shall be taken to avoid damage to the beach access ramp located at Plaza Street during construction and repairs. If damage to the ramp occurs, it shall be repaired to a condition equivalent to the condition at the start of construction activity to the satisfaction of the City of Solana Beach City Engineer.

If access is from the State Park at the north end of Solana Beach, precautions shall be taken to avoid damage to the hard layer of fossiliferous sandstone which forms the beach surface at the north end of the coastal bluffs. Such access may necessitate State approval. Proof of such access shall be provided to the City Engineer before construction begins.

d. The applicant and/or contractor shall obtain a haul route permit from the City Engineering Department.

XV. The Applicant shall as required by the City Attorney, either: (a) submit a complete application to merge the two tax assessor parcels into one legal lot to assure single ownership and responsibility of the seawall area; or (b) present evidence that a long-term maintenance agreement has been entered into between the property owners to insure the bluff property and seawall are properly maintained.

B. Prior to Final Inspection of the project, the Applicant shall:

I. Submit certification to the City Engineer from the Geotechnical Engineer and the Civil Engineer or Record for the project that they have inspected the project and certify that it was constructed per the approved plan, specifying the date of the plan.

II. The applicant and/or contractor shall repair any damage caused to the Solana beach Fletcher Cove ramp and parking lot to the satisfaction of the City Engineer.

C. The Applicant shall provide for and adhere to the following Conditions:

I. All development on the site shall substantially conform to the final Special Use Permit Plan approved by the Community Development Director.

II. No construction activity shall be allowed within the period between Memorial Day and Labor Day in order to minimize potential impacts to recreational beach uses.

III. Shoreline Defense Structure:

a. The proposed shoreline defense structure will be:

- i. The minimum measure necessary to provide a reasonable level of protection; and
- ii. Constructed and maintained to incorporate an earth-like appearance which will resemble as closely as possible the natural color and texture of the adjacent bluffs; and
- iii. Constructed and maintained to reasonable conform to the natural form of the bluff; and
- iv. Placed at the most feasible land-ward location; and
- v. Appropriately landscaped and maintained to blend in with the existing environment.

b. The shoreline defense structure will be located entirely on private property or, if the structure will be located partially or entirely on public property or property subject to a public trust, all required permits for construction or real property interests have been obtained, or will be obtained, from the appropriate public agency or agencies with jurisdiction and/or ownership.

c. The construction of the structure and reconstruction of the bluff face, if any, will not result in a usable area at the top of the bluff larger than existed on January 3, 1991 or extend the bluff-top edge seaward more than 10 feet from the bluff-top edge as it existed on January 3, 1991 as shown on the ortho-photo map of the City dated January 3, 1991 and on file in the Planning Department.

IV. The property owner shall be responsible to immediately remove, in perpetuity, any graffiti or other markings should they appear on the project exterior face.

D. The Special Use Permit for the project will expire on November 9, 1999 unless the Applicant has obtained necessary permits and has commenced construction prior to that date, and diligently pursues construction to completion. An extension of the Special Use Permit may be granted by the City Council.

E. NOTICE TO APPLICANT: Pursuant to Government Code Section 66020, you are hereby notified that the 90-day period to protest the imposition of the fees, dedications, reservations or other executions described in this resolution commences on the effective date of this resolution. To protest the imposition of any fees, dedications, reservations or other exaction's described in this resolution, you must comply with the provisions of Government Code Section 66020. Generally the resolution is effective upon expiration of the tenth day following the date of adoption of this resolution, unless the resolution is appealed or called for review as provided in the Solana Beach Ordinance.

^{Adjourned}
PASSED AND ADOPTED at a regular meeting of the City Council of the City of Solana Beach, California, held on the 9th day of November, 1998, by the following vote.

AYES: Councilmembers – Campbell, Dodson, Kellejian, Tompkins

NOES: Councilmembers – None

ABSENT: Councilmembers – None

ABSTAINED: Councilmembers – None



PAUL S. TOMPKINS, Mayor

ATTEST:



KATHRYN A. KIRK, City Clerk

APPROVED AS TO FORM:

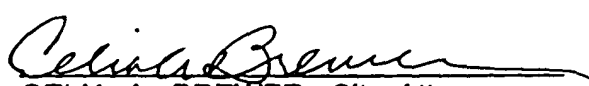

CELIA A. BREWER, City Attorney

STATE OF CALIFORNIA)
COUNTY OF SAN DIEGO) SS
CITY OF SOLANA BEACH)

I, Kathryn A. Kirk, City Clerk of the City of Solana Beach, do hereby certify that the foregoing is the original of Resolution No. 98-101 duly passed, approved, and adopted by the City Council at a Adjourned Regular meeting of the Solana Beach City Council held on the 9th day of November, 1998.

Executed this 9th day of November, 1998.

Kathryn A. Kirk
Kathryn A. Kirk, City Clerk

(SEAL)

RESOLUTION 2014-111

A RESOLUTION OF THE CITY COUNCIL OF THE CITY OF SOLANA BEACH, CALIFORNIA, CONDITIONALLY APPROVING A DEVELOPMENT REVIEW PERMIT FOR MAINTENANCE AND REPAIR OF AN EXISTING 352-FOOT LONG TIED BACK SEAWALL LOCATED AT THE BASE OF THE LOWER COASTAL BLUFF BELOW 249-311 PACIFIC AVENUE.

**APPLICANT: Terry Lingenfelder
CASE NO.: 17-13-33 DRP**

WHEREAS, Terry Lingenfelder (hereinafter referred to as "Applicant") has submitted an application for a Development Review Permit (DRP) pursuant to Title 17 (Zoning), of the Solana Beach Municipal Code (SBMC); and

WHEREAS, the Applicant has submitted a Seawall Monitoring Report prepared by TerraCosta Consulting Group on November 22, 2013, which has been reviewed and confirmed by Geopacifica Geotechnical Consultants (Geopacifica), the City's third party independent geotechnical consultant, in a final revision dated February 19, 2014, entitled *Review of Request for Seawall Repair 249-311, Solana Beach, CA*, indicating that maintenance and repair of the existing seawall at the property is required; and

WHEREAS, at the duly noticed public hearing held on August 27, 2014, the City Council received and considered evidence concerning the proposed application as received; and

WHEREAS, the public hearing was conducted pursuant to the provisions of Solana Beach Municipal Code Section 17.72.030; and

WHEREAS, the City Council of the City of Solana Beach found the application request exempt from the California Environmental Quality Act pursuant to State CEQA guidelines sections 15301(d); and

WHEREAS, the proposed maintenance will be designed and constructed to maximize the natural, aesthetic appeal and scenic beauty of the beach and bluff by the reapplication of color coating to match the surrounding seawalls and exposed bluffs; and

WHEREAS, this decision is based upon the evidence contained in the subject application, testimony of Geopacifica, evidence presented at the hearing and any information the City Council gathered by viewing the site and the area as disclosed at the hearing.

NOW THEREFORE, the City Council of the City of Solana Beach, California, does resolve as follows:

1. That the foregoing recitations are true and correct.

2. That the project is categorically exempt from the requirements of CEQA pursuant to 2013 State California CEQA Guidelines 15301(d).
3. That the request for a Development Review Permit for the maintenance and repair of an existing 352-foot tied-back seawall along the coastal bluff below the properties at 249-311 Pacific Avenue is conditionally approved based upon the following Findings and subject to the following Conditions:

4. FINDINGS

- A. In accordance with Section 17.68.040 (Development Review Permit) of the City of Solana Beach Municipal Code, the City Council finds the following:
 - I. *The proposed project is consistent with the General Plan and all applicable requirements of SBMC Title 17 (Zoning Ordinance), including special regulations, overlay zones and specific plans.*

General Plan Consistency: The proposed project, as conditioned, is consistent with the City's General Plan land use designation of Medium-Density Residential, which allows for the development of single and multiple-family developments at a density of 5-7 dwelling units per acre. The proposed project, as conditioned, is consistent with the objectives of the General Plan as it encourages the development and maintenance of healthy residential neighborhoods, the stability of transitional neighborhoods, and the rehabilitation of deteriorated neighborhoods. The project could be found to be consistent with these criteria because the scope of the project will maintain the existing use of the single-family residences currently developed on the associated properties.

Zoning Ordinance Consistency: The proposed project is consistent with all applicable requirements of the Zoning Ordinance (Title 17) (SBMC 17.48.040), and delineates Permitted Uses and Structures (SBMC Section 17.20.020), and provides for uses of the properties for a single-family residences. Further, the proposed project adheres to all property development regulations established for the Medium Residential (MR) Zone which allows for the development of a multi-family development at a density of 5-7 dwelling units per acre.

The project does not propose any development changes that would affect existing yard dimensions, maximum FAR, and parking regulations. No increases to the existing height or existing setbacks would occur with project implementation. The west end of the property along the coastal bluff is located within the HOZ. SBMC Section 17.48.020 states the purpose of the HOZ regulations is to: restrict grading of natural slopes with an inclination of 25 percent or greater, in order to preserve the natural topography and scenic qualities of the City; protect native coastal

sage/chaparral and grassland habitat; preserve existing watersheds; and reduce the potential for environmental hazards.

II. *The proposed development complies with the following development review criteria set forth in Solana Beach Municipal Code Section 17.68.040.F:*

- a. *Relationship with Adjacent Land Uses: The development shall be designed in a manner compatible with and where feasible, complimentary to existing and potential development in the immediate vicinity of the project site. Site planning on the perimeter of the development shall give consideration to the protection of surrounding areas from potential adverse effects, as well as protection of the property from adverse surrounding influences.*

The project is for the maintenance and repair of an existing seawall located at the base of the lower coastal bluff. The proposed project does not modify the land use or relationship with adjacent land uses. No adverse effects upon neighboring properties have been identified or are anticipated to occur from the project implementation. As conditioned, the proposed project gives consideration to the protection of surrounding areas from potential adverse effects and provides protection of the property from adverse surrounding influences.

- b. *Building and Structure Placement: Buildings and structures shall be sited and designed in a manner which visually and functionally enhances their intended use.*

No buildings are proposed. The proposed repairs will include the reapplication of at least 6 inches of sacrificial concrete to cover the lower 14 to 18 feet of the wall in order to cover the exposed anchor heads and erosional markers. The concrete will also fill any concave depressions formed in the wall as a result of cobble induced abrasion. The damaged plastic anchor heads will be replaced and the color coating will be reapplied to match the surrounding seawalls and exposed bluff constructed and maintained to incorporate an earth-like appearance, which will resemble, as closely as possible, the color and texture of the surrounding bluffs.

- c. *Landscaping: The removal of significant native vegetation shall be minimized. Replacement vegetation and landscaping shall be compatible with the vegetation of the surrounding area. Trees and other large plantings shall not obstruct significant views when installed or at maturity.*

The project, as proposed, is for the maintenance and repair of an existing seawall and no landscaping is proposed. If the Applicant decided to process a permit for upper bluff landscaping at a later date, they will be conditioned to provide native, non-invasive, drought tolerant, fire-resistant and salt tolerant species. A landscaping plan would be required at that time.

- d. *Roads, Pedestrian Walkways, Parking and Storage Areas: Any development involving more than one building or structure shall provide common access roads and pedestrian walkways. Parking and outside storage areas, where permitted, shall be screened from view, to the extent feasible, by existing topography, by the placement of buildings and structures, or by landscaping and plantings.*

No modification to roads, pedestrian walkways or parking or storage areas is proposed by this project. Common access roads and pedestrian walkways are not required. No additional parking or outside storage areas are proposed.

- e. *Grading: To the extent feasible, natural topography and scenic features of the site shall be retained and incorporated into the proposed development. Any grading or earth-moving operations in connection with the proposed development shall be planned and executed so as to blend with the existing terrain both on and adjacent to the site. Existing exposed or disturbed slopes shall be landscaped with native or naturalized non-native vegetation and existing erosion problems shall be corrected.*

There is no proposed grading or building on site as shown on the proposed plans. Any sand that is removed to maintain and repair the bottom of the existing seawall will be replaced once the work is complete.

- f. *Lighting: Light fixtures for walkways, parking areas, driveways, and other facilities shall be provided in sufficient number and at proper locations to assure safe and convenient nighttime use. All light fixtures shall be appropriately shielded so that no light or glare is transmitted or reflected in such concentrated quantities or intensities as to be detrimental to the surrounding areas per SBMC 17.60.060 (Exterior Lighting Regulations).*

The project does not involve exterior lighting improvements; however, in the event these improvements do occur, the project is conditioned for consistency with the City's Exterior Lighting Regulations in that all new exterior lighting fixtures

shall be in conformance with the Citywide Lighting Regulations of the Zoning Ordinance (SBMC 17.60.060).

- g. *Usable Open Space: Recreational facilities proposed within required usable open space shall be located and designed to maintain essential open space values.*

The project consists of the maintenance and repair of an existing seawall, therefore, usable open space and recreational facilities are neither proposed nor required according to SBMC Section 17.20.040.

- III. *All required permits and approvals including variances, conditional use permits, comprehensive sign plans, and coastal development permits have been obtained prior to or concurrently with the development review permit.*

All required permits are being processed concurrently with the Development Review Permit or have already been obtained. As a condition of project approval, the Applicant is required to obtain a permit from the California Coastal Commission prior to building/grading permit issuance.

5. CONDITIONS

Prior to use or development of the property in reliance on this permit, the Applicant shall provide for and adhere to the following conditions:

A. Community Development Department Conditions:

- I. The Applicant shall pay required Public Facilities Fees, as established by SBMC Section 17.72.020 and Resolution 1997-36.
- II. Building Permit plans must be in substantial conformance with the plans presented to the City Council on August 27, 2014 and located in the project file with a submittal date of October 22, 2013.
- III. The Applicant shall obtain required California Coastal Commission (CCC) approval of a Coastal Development Permit, Waiver or Exemption as determined necessary by the CCC, prior to the issuance of a grading or building permit.
- IV. The repairs to will be constructed and maintained to incorporate an earth-like appearance, which will resemble, as closely as possible, the color and texture of the surrounding bluffs.
- V. The Coastal Structure shall be maintained and repaired on an "as

needed" basis to ensure continued compatibility with the color, texture and topography of the contiguous areas, and to ensure that all surrounding areas are kept safe. The Coastal Structure shall be subject to periodic inspection by officers or agents of the City to determine compliance with the terms and conditions of this Resolution.

- VI. In order to show compliance with LUP Policy 4.26, the Applicant shall remove or cap any permanent irrigation system within 100 feet of the bluff edge, unless the Applicant demonstrates, to the satisfaction of the Public Works Director, or the CCC if the project is appealed, that such irrigation has no material impact on bluff erosion.
 - VII. All bluff property landscaping shall consist of native, non-invasive, drought-tolerant, fire-resistant, and salt-tolerant species.
 - VIII. Any new exterior lighting fixtures shall be in conformance with the Citywide Lighting Regulations of the Zoning Ordinance (SBMC 17.60.060).
 - IX. Should mitigation fees be imposed as part of the CDP process for the proposed maintenance or during the assessment of the project in accordance with LUPA policy 4.48.C, the City shall receive payment of mitigation fees for the mitigation of adverse impacts to public access and recreational use resulting from the subject shoreline protective devices
- B. Engineering Department Conditions: Prior to obtaining any building or grading permits pursuant to this colored concrete seawall maintenance project, the Applicant shall:
- I. Prepare, execute and record a declaration of restrictions on real property approved by the City Attorney whereby the Applicant or the Applicant's successors in interest to the property will construct and maintain the shoreline defense structure in accordance with Conditions of this approval.
 - II. Execute a waiver of all claims against the City of Solana Beach for future liability or damage resulting from permission to build as granted under this permit. Said waiver shall be acknowledged and recorded in the Office of the County Recorder.
 - III. Obtain required California Coastal Commission Permits prior to the issuance of any structure and grading permits or present evidence that an emergency waiver has been granted.

- IV. Obtain any other permits or emergency waivers, which may be required, from State and Federal agencies including the State Lands Commission and the U.S. Army Corps of Engineers.
- V. The project shall be designed and shall provide appropriate data to confirm the submitted design to the satisfaction of the City Engineer. This shall include, but is not limited to, a geotechnical report.
- VI. The property owners shall post securities to guarantee proper care and use of the Fletcher Cove ramp. No construction materials to be off-loaded on the ramp, at the end of the ramp or any public property including streets and Fletcher Cove Park. No washing of equipment shall occur unless a containment system is properly utilized.
- VII. For all projects on which equipment is driven on the Fletcher Cove Beach Access Ramp, the access ramp and adjacent parking lot must be swept daily to remove sand that has been tracked onto the Ramp and parking lot. At least once a week, the access ramp and parking lot must be swept with a street sweeper that is capable of cleaning the streets and parking lots of paper, glass, dirt, silt, sand, rocks, litter and miscellaneous debris. The street sweeper shall be equipped with dual gutter brooms and vacuum equipment may be used. If any sand is tracked outside the parking lot, these areas (including City streets) must also be cleaned weekly with a street sweeper.
- VIII. The property owners shall pay all inspection and plan check fees as required by the City.
- IX. Plans and specifications for the project shall be approved by the City Engineer in addition to approvals from the Director of Planning as may be required, and shall substantially conform to the plans submitted by the Applicant. All bluff stabilization devices shall produce a natural appearing bluff to the satisfaction of the City Engineer and the Community Development Director. Project implementation shall provide a final product mimicking a naturally appearing bluff in terms of colors, textures, forms and angles.
- X. A grading/drainage plan shall be prepared by a registered civil engineer in accordance with the current Grading Ordinance and be submitted to the City Engineer for the approval and permit issuance.
- XI. Plans and specifications for the project shall be approved by the Planning Department prior to submittal to the Engineering Department.
- XII. The Applicant shall post with the City a Performance Bond equal to the full amount of the work to be completed to guarantee that once started, construction will be completed per plans.

- XIII. The Applicant shall submit a Certificate of Insurance naming the City of Solana Beach as an additional insured in the amount of \$1,000,000 on a policy of general liability insurance issued by an insurance company licensed to do business in California, and meeting the requirements established by City Council resolution for insurance companies doing business with the City covering injuries to persons and property during the construction period.
- XIV. The Applicant shall obtain a Special Use (Marine Safety) Permit specifying the conditions governing use of vehicles, use of the access ramp, and entry upon and use of areas of the public beach for construction equipment and vehicles. Evidence of permit issuance shall be submitted to the City Engineer before issuance of the permit for the project.
- XV. The Applicant shall have on file evidence from the Captain of Marine Safety and the City Engineer of the City of Solana Beach that arrangements have been made to satisfy the following criteria:
- a. Prior to the usage of the Solana Beach Fletcher Cove Ramp or parking lot, a cash deposit, bond or other secured agreement to cover the following impact charges shall be deposited:
 - i. A five-dollar and thirty-cents (\$5.30) per round trip vehicle charge for all construction related vehicles using the ramp.
 - ii. A two-dollar and seventy cents (\$2.70) per ton fee, or less if approved by the City Council, based on the estimated weight of the vehicle and load for all vehicles in excess of $\frac{3}{4}$ ton capacity, excluding any vehicles solely transporting beach grade replenishment sand.
 - iii. A twenty-seven dollar (\$27) per day charge for the first 30 days escalating to fifty-three dollars (\$53) per day for the 31st and subsequent days charge shall be collected to encourage a timely completion of all projects, unless otherwise modified for good cause by the City Council or City Manager.
 - iv. Any damage caused to the Solana Beach Fletcher Cove Ramp and parking lot.
 - b. At least one City of Solana Beach Lifeguard shall be contracted, at the Applicant's expense, through the Captain of Marine Safety, to monitor all activities in order to ensure full compliance with the condition of this permit. The

lifeguard(s) shall be on duty at all times when any construction activity takes place. Additional lifeguards may be required at the discretion of the Captain of Marine Safety. In addition to the lifeguard staffing cost, the Applicant shall also pay a Marine Safety equipment use fee of four dollars and sixty-four cents (\$4.64) per hour, based on the number of hours the lifeguards are contracted for the project.

- c. If construction access is from Fletcher Cove Park, precautions shall be taken to avoid damage to the beach access ramp during construction and repairs. If damage to the ramp occurs, it shall be repaired to a condition equivalent to the condition at the start of construction activity to the satisfaction of the City of Solana Beach City Engineer. All City owned work areas including Fletcher Cove Park and access ramp shall be videotaped prior to the commencement of the project. The videotape shall establish the "as-is" condition. In any areas missed by the videotape, the City Engineer will determine the "as-is" condition.

If access is from the State Park at the north end of Solana Beach, precautions shall be taken to avoid damage to the hard layer of fossiliferous sandstone that forms the beach surface at the north end of the coastal bluffs. Such access may necessitate State approval. Proof of such access shall be provided to the City Engineer before construction begins.

- XVI. Beach quality sand from the excavation for the proposed project shall be deposited and spread on the beach in front of this site unless unique and/or inappropriate conditions are encountered. The Applicant should reference this condition to other permitting agencies.
- XVII. An encroachment permit form the Engineering Department is required if a crane, construction materials, etc. are envisioned to be stationed in the public right of way. The City does not guarantee that an encroachment permit will be approved.
- XVIII. Any grout mixture used on the project that may be visible from the beach or surrounding areas. Color samples shall be submitted and approved by the City prior to placing the grout.
- XIX. The structure and any exposed construction shall mimic the natural contours, color and texture to the maximum extent practicable, as determined by the City Engineer and Community Development Director.

- XX. A carved, colored, and textured façade on the face of the structure matching the adjacent bluff areas shall be constructed. The façade shall match the contours, both vertically and horizontally, and the texture of the adjacent natural bluffs to the maximum extent feasible. Coastal bluff colored grouting shall be used and shall be submitted to the City Engineer before approval of the plans. A test prism shall be cast and delivered to a testing lab during construction.
 - XXI. A qualified, licensed and insured contractor shall perform all required work as outlined by certified/registered engineering geologist or a registered civil engineer on the construction plans. Special and general notes on said plans shall be followed to the satisfaction of the City Engineer or his designee.
 - XXII. Lateral pedestrian and Marine Safety vehicular access through the construction area shall be provided past the site at all times, subject to high tides and safety issues. A 30-foot wide safety/ construction work zone shall be provided during work hours to separate the work zone from the open public beach.
 - XXIII. No construction activities may occur on the beach during the busier recreation season, which is defined as the period between Memorial Day and Labor Day of any year. The contractor shall obtain approval from the City of Solana Beach Engineering and Marine Safety Departments regarding the use and timing of the Fletcher Cove parking lot and beach access ramp for all construction related access, staging and parking lot issues if such use becomes required.
- C. Prior to final inspection of the project, the Applicant shall:
- I. Submit certification to the City Engineer from the Geotechnical Engineer and the Civil Engineer of Record for the project that they have inspected the project and certify that it was constructed per the approved plan, specifying the date of the plan.
 - II. The Applicant and/or contractor shall repair any damage caused to the Solana Beach property and facilities including, but not limited to, Fletcher Cove Ramp and parking lot to the satisfaction of the City Engineer.
- D. The Applicant shall provide for and adhere to the following conditions:
- I. All development on the site shall substantially conform to the final Conditional Use Permit Plan approved by the City Council.

- II. The property owner shall be responsible to immediately remove, in perpetuity, any graffiti or other markings should they appear on the project exterior face. If erosion exposes the steel rebar, the Applicant or their successor in interest shall arrange to apply a sculptor-coat of concrete over the exposed steel to match the natural bluff. The property owner shall be responsible for the removal of the structure or any portion thereof.
 - III. If requested by the City Manager or his designee, the property owner or their successor in interest shall install and maintain signage about unstable bluffs fronting their property.
 - IV. The Applicant shall provide "As-Built" plans and all certification required to the City, before the City will release the performance bond as indicated in condition 1.XII.
 - V. Pursuant to SBMC Section 7.34.100, Construction hours are limited to 7:00a.m. to 7:00p.m., Monday through Friday, and 8:00a.m. on Saturday. No work is allowed on Sunday or holidays unless specifically approved pursuant to SBMC Section 7.34.100.B. Engines shall not be started, no construction-related materials shall be moved, or any other construction-related activities occur outside these hours. Work is not permitted on the beach on Saturdays without the written approval of the City Manager.
6. ENFORCEMENT: Pursuant to SBMC 17.72.120(B) failure to satisfy any and all of the above-mentioned conditions of approval is subject to the imposition of penalties as set forth in SBMC Chapters 1.1.6 and 1.18 in addition to any applicable revocation proceedings.
 7. EXPIRATION: The Development Review Permit for the project will expire on August 27, 2016, unless the Applicant has obtained building permits and commenced construction prior to that date, and diligently pursued construction to completion. An extension of the application may be granted by the City Council.
 8. INDEMNIFICATION AGREEMENT: The Applicant shall defend, indemnify, and hold harmless the City, its agents, officers, and employees from any and all claims, actions, proceedings, damages, judgments, or costs, including attorney's fees, against the City or its agents, officers, or employees, relating to the issuance of this permit including, but not limited to, any action to attack, set aside, void, challenge, or annul this development approval and any environmental document or decision. The City will promptly notify applicant of any claim, action, or proceeding. The City may elect to conduct its own defense, participate in its own defense, or obtain independent legal counsel in defense of any claim related to this indemnification. In the event of such election, applicant shall pay all of the costs related thereto, including without limitation reasonable attorney's fees and costs. In the event of a disagreement between the City and

applicant regarding litigation issues, the City shall have the authority to control the litigation and make litigation related decisions, including, but not limited to, settlement or other disposition of the matter. However, the applicant shall not be required to pay or perform any settlement unless such settlement is approved by applicant.

9. NOTICE TO APPLICANT: Pursuant to Government Code Section 66020, you are hereby notified that the 90-day period to protest the imposition of the fees, dedications, reservations or other exactions described in this resolution commences on the effective date of this resolution. To protest the imposition of any fee, dedications, reservations or other exactions described in this resolution you must comply with the provisions of Government Code Section 66020. Generally the resolution is effective upon expiration of the tenth day following the date of adoption of this resolution, unless the resolution is appealed or called for review as provided in the Solana Beach Zoning Ordinance.

PASSED AND ADOPTED at a regular meeting of the City Council of the City of Solana Beach, California, held on the 27th day of August, 2014, by the following vote:

AYES: Councilmembers – Campbell, Heebner, Zito, Zahn, Nichols
NOES: Councilmembers – None
ABSTAIN: Councilmembers – None
ABSENT: Councilmembers – None

THOMAS M. CAMPBELL, Mayor

APPROVED AS TO FORM:

JOHANNA N. CANLAS, City Attorney

ATTEST:



ANGELA IVEY, City Clerk



CERTIFICATION

STATE OF CALIFORNIA)
COUNTY OF SAN DIEGO) SS.
CITY OF SOLANA BEACH)

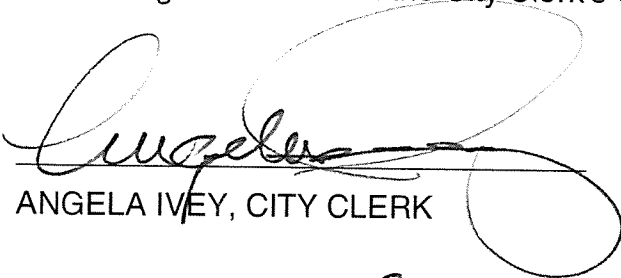
I, ANGELA IVEY, City Clerk of the City of Solana Beach, California, DO HEREBY CERTIFY that the foregoing is a full, true and correct copy of **Resolution 2014-111** *conditionally approving a Development Review Permit at 249-311 Pacific Ave, Case No. 17-13-33, Applicant: Lingenfelder* as duly passed and adopted at a Regular Solana Beach City Council meeting held on the 27th day of August 2014 and the original is on file in the City Clerk's Office.

ANGELA IVEY, CITY CLERK

Date of this Certification: 9-8-2014

Project No.
T1831.H01.001

August 17, 2023

Ms. Diana Lilly
California Coastal Commission
7575 Metropolitan Drive, Suite 103
San Diego, California 92108

Subject: 249-311 Pacific Avenue
Solana Beach, California

SEAWALL MONITORING REPORT

Permit Reference: California Coastal Commission; CDP No. 6-99-100 (249-311 Pacific Avenue) and CDP No. 6-13-0437 (249 Pacific Avenue seawall extension)

Dear Ms. Lilly:

In accordance with Special Condition No. 3 of Coastal Development Permit (CDP) No. 6-99-100 and Special Condition No. 6 of CDP No. 6-13-0437, we are submitting this monitoring report. The purpose of this report is to provide a current evaluation of the performance of the seawall at 249-311 Pacific Avenue, and its southerly extension at 249 Pacific Avenue.

This report contains our opinion of trends, the differential retreat of the upper bluff materials and any significant weathering or damage to the seawall below, as required by Special Conditions Nos. 2 and 3 as mentioned above. Our opinions are based on comparison of current measurements and observations made at the residences of 249 through 319 Pacific Avenue to those reported in our previous monitoring reports. The original baseline report for CDP No. 6-99-100 was submitted March 31, 2003, with follow-up reports submitted June 3, 2005, and November 22, 2013.

This report represents our fourth monitoring report for the seawall at 249-311 Pacific Avenue (CDP No. 6-99-100), and our initial baseline report for the seawall extension below 249 Pacific Avenue (CDP No. 6-13-0437). Measurements and observations of the upper bluff edge for these eight properties were performed on May 19, 2022. Due to high sand levels at that time, measurements and observations of the seawall below were not able to be completed until April 26, 2023.

PROJECT BACKGROUND AND MONITORING HISTORY

The 249-311 Pacific Avenue project was initiated in October 1998 with an Emergency Permit application to the Coastal Commission for construction of a 352-foot-long, 35 foot-high, 2 1/2 foot-thick, tied-back seawall following the coastal bluff failure that occurred on September 30, 1998. The most significant bluff retreat occurred in the vicinity of 261 Pacific Avenue as a result of the accelerated erosion that occurred during the previous winter's El Niño storm season. The Coastal Commission issued an Emergency Permit in April 1999 for a 90-foot portion of the seawall, built

early that summer, followed by a February 2000 Emergency Permit to construct the remaining 260± feet of seawall. The wall structure itself was completed in the early summer of 2000, while architectural finishing was completed in December 2000. Upper-bluff reconstruction in the vicinity of 261 Pacific Avenue was also near completion by the end of the year, more than two years after the initial Emergency Permit request was submitted to Coastal Commission Staff.

The baseline monitoring report for this wall was submitted to Coastal Commission Staff on March 31, 2003. An updated monitoring report was submitted on June 3, 2005. Maintenance work on the seawall was performed in 2006 to address issues noted in the 2005 monitoring report. Additional maintenance of the 352-foot-long was approved by Coastal Commission staff under the amended CDP No. 6-05-095-A1 and completed in April 2017. Maintenance consisted of the reapplication of 6-9 inches of sacrificial concrete covering the lower 14-18 feet of the wall. An as-built report titled "Seawall Maintenance, 249-311 Pacific Avenue, Solana Beach, California," was prepared by TerraCosta Consulting Group, Inc., and submitted to the Coastal Commission on June 7, 2017.

Since the initial construction of the 249-311 Pacific Avenue seawall only protected the northerly half of the bluff at 249 Pacific Avenue, significant erosion of the bluff continued on the unprotected portion of this property. Construction of the 24-foot long by 35-foot high tied-back seawall extension below 249 Pacific Avenue was approved under CDP 6-13-0437 and completed in March 2015. This report will also serve as the baseline monitoring report for the southern portion of the seawall as described above.

In addition, while performing field observations of the seawalls it was discovered that the maintenance performed under CDP No. 6-05-095-A1 covered the existing monitoring pins for the wall from 249-311 Pacific Avenue with the colored sacrificial concrete. Because of this discovery we were obligated to install new monitoring pins along the full length of the seawall, ultimately making this report a new baseline for entire length of the seawall from 249-311 Pacific Avenue.

MONITORING PROCEDURES

This monitoring report follows the procedures set forth in the Coastal Commission-approved proposal for seawall monitoring and is composed of the following four parts:

- Visual evaluation of current condition and performance of seawall;
- Measurements of seawall abrasion and natural bluff retreat;
- Visual evaluation of any progressive erosion of the upper sloping surface; and
- Measurements of distance from residences to bluff edge.

This monitoring survey was conducted on two occasions. The upper-bluff survey was performed on May 19, 2022, and the seawall portion was completed on April 26, 2023.

Monitoring procedures consisted of visually evaluating and describing the seawall and bluff-top areas; measuring the seawall using permanent steel monitoring pins installed in the seawall as reference points; and, finally, measuring the top of the bluff using reference points along the west-facing side of each residence. Bluff-top reference locations are shown on Figure 1. Seawall monitoring pin locations are shown on Figures 1 through 4. A few of the bluff-top monitoring points have been destroyed over time, as indicated on Figure 1 and new points acquired. No previously installed seawall monitoring pins could be reacquired for comparative measurements along the seawall, so ten new steel pins from 249-319 Pacific Avenue were installed to establish a baseline against which to measure erosional changes of the architectural wall face.

We have provided photographs with written descriptions of the general condition of the contiguous seawalls, including color, texture, observable erosion, and any observed separation between the seawall and an adjacent seawall.

VISUAL EVALUATION OF SEAWALL CONDITION AND PERFORMANCE

This report evaluates the two contiguous seawalls constructed and/or maintained in separate sections comprised of the southern half of 311 Pacific Avenue down to the northern half of 249 Pacific Avenue, and the southerly section below the southern half of 249 Pacific Avenue. These two walls were constructed to blend together in a natural manner without a noticeable contact point to draw the beach-goers attention.

Visual inspection of the seawalls in general reveals negligible surficial changes since construction of the northern and southern portions, or the 2017 maintenance of the central portion. Our current site inspection reveals little apparent surficial distress or deep-seated structural distress.

Photos 1 through 6 show the overall condition of the exposed portions of the seawalls at the time of this survey above approximate elevation 7.5 to 10 feet (MSL). As can be seen in the photographs, except for minor typical weathering and efflorescence, visual inspection revealed no apparent distress or any indications suggestive of structural distress that would affect the integrity of the seawall.

VISUAL EVALUATION OF UPPER SLOPING BLUFF SURFACE

Photos 7 through 16 illustrate the amount of surficial erosion and sloughing that has occurred on the face of the upper bluff since 2013. In particular, our comparative review of Photos 11 and 14 indicate that surficial (rill) erosion of the geogrid-reinforced fill slope below 255, 261 and 265 Pacific Avenue continues to occur due in part to the lack of protective vegetative cover. As indicated in Photos 13 and 14, erosion gullies have developed along the grid-reinforced fill/formational bluff contact below 255 Pacific Avenue. Photos 17 through 32 provide a chronologic comparison of the upper bluff condition, which appears to remain largely unchanged since the previous monitoring report.

MEASUREMENTS OF SEAWALL ABRASION

For the two contiguous seawalls, vertical and horizontal profiles have been prepared using the monitoring pins as reference points. The results of vertical and horizontal profiles for each wall are shown on Figures 2 through 7. It should be noted that the vertical profiles terminate at the back-beach elevation that was present on March 26, 2023, the date of the survey.

Using the newly installed monitoring pins as a baseline against which to measure the contiguous seawalls, we have developed horizontal profiles of the seawall at the new pin locations. Horizontal profiles were measured using a conventional 100-foot tape laid at sand level against the base of the exposed seawall or at pin elevation, depending on what conditions would allow. Horizontal offsets were measured from the seawall face to the intersection of the measuring tape using a folding rule. Vertical profiles were measured using a construction level as a vertical reference point with a tape measure to determine horizontal offset.

As this report has become the new baseline by which to measure future seawall erosion, no conclusions can be drawn at this point as to the rate of erosion of the sacrificial concrete placed during maintenance completed in 2017. It should be noted that future reports are expected to

reveal that the erosion rate will likely not be uniform over the entire exposed surface of the seawalls, but is expected to occur in random, localized areas.

DISTANCE MEASUREMENTS FROM RESIDENCE TO BLUFF EDGE

As stated previously, and as indicated on Figure 1, reference locations have been established along the rear-facing foundation of each residence for monitoring any bluff-top retreat. Photos 15 through 30 show overall views of the rear yards of the subject properties comparing any bluff-top changes between November 4, 2013, and May 19, 2022. As seen in these photographs, essentially only minor changes to the bluff top have occurred.

The following table summarizes our measurements of the distance from the approximate monitoring reference points to the top-of-bluff. Numbers shown in ***bold italics*** represent monuments that have been obliterated since the 2005 survey and are included for informational purposes only.

Property Address/Pin #	2005 (ft)	2013 (ft)	2022 (ft)	Total Change Since 2005 (ft)
311 Pacific Ave				
1	9.1	8.05	7.7	(1.4)
1a	10.9	9.7	9.7	(1.2)
2	12.0	11.1	11.1	(0.9)
3	8.8	5.8	5.8	(3.0)
3a	9.5	7.95	7.95	(1.55)
4	11.0	10.55	10.55	(0.45)
5	13.35	13.35	13.35	0
6	14.5	14.3	14.3	(0.2)
309 Pacific Ave				
7	13.9	13.9	13.9	0
8	15.9	15.9	15.9	0
9	11.2	11.2	11.2	0
10	13.1	12.8	12.8	(0.3)
11	13.4	13.4	13.4	0
12	13.4	--	--	--
301 Pacific Ave				
13	10.0	10.0	10.0	0
14	9.8	9.8	9.8	0
15	25.4	25.4	25.4	0
16	26.8	26.8	26.8	0
17	28.8	28.8	28.8	0
18	29.3	28.0	28.0	(1.3)
269 Pacific Ave				
19	20.5	20.1	20.1	(0.4)
20	16.4	16.4	16.4	0
21	11.6	10.1	10.1	(1.5)
22	12.0	11.7	11.7	(0.3)
23	12.3	12.3	12.3	0
24	18.3	--	--	--

Property Address/Pin #	2005 (ft)	2013 (ft)	2022 (ft)	Total Change Since 2005 (ft)
265 Pacific Ave				
25	23.5	23.5	23.5	0
26	25.5	25.5	25.5	0
27	21.5	21.5	21.5	0
28	20.0	20.0	20.0	0
29	20.6	20.6	20.6	0
30	11.2	11.2	11.2	0
261 Pacific Ave				
31	27.1	27.1	27.1	0
32	27.1	27.1	27.1	0
32	27.1	27.1	27.1	0
34	29.1	29.1	29.1	0
35	10.5	10.5	10.5	0
255 Pacific Ave				
36	25.9	25.9	25.9	0
37	23.2	23.2	23.2	0
38	22.7	22.7	22.7	0
39	22.5	22.5	22.5	0
40	14.5	14.4	14.4	(0.1)
249 Pacific Ave				
41	--	--	--	--
42	21.0	20.6	20.6	(0.4)
43	24.0	24.0	--	--
43a	--	--	25.5	--
44	26.0	26.0	--	--
45	25.2	25.2	--	--
45a	--	--	25.7	--
46	24.1	24.1	--	--

As indicated by the measurements in the table, approximately 3.0 feet of loss behind 311 Pacific Avenue is the most significant recession that has occurred along the top-of-bluff since 2005. It should be noted that the distance measurement to the top-of-bluff is somewhat approximate due to the fact that the bluff top is not a well-defined edge, but rather a rounded zone of increasing steepness between the relatively level backyard and the sloped face of the upper bluff. Additionally, ground cover along the top of the bluff may make precise measurement difficult. For our measurements, we used the Coastal Commission’s definition of the bluff edge, defined as “that point nearest the cliff beyond which the downward gradient of the land surface increases more or less continuously until it reaches the general gradient of the cliff.” At the time of this survey, the surface of the sloping upper bluff appears to be relatively stable, with no evidence of any recent upper-bluff erosion.

CONCLUSIONS AND RECOMMENDATIONS

This assessment of the contiguous seawalls indicates that they are structurally sound and performing well at the present time. The surface textures and colors, although beginning to show

wear in some areas, are very similar to the adjacent seawalls and blend in well with the surrounding landforms.

Upper-Bluff Maintenance

Overall, the upper bluff appears to have weathered well over the past seventeen years. However, continuous surficial rilling in the area of the geogrid-reinforced slope below 255-265 Pacific Avenue appears to have occurred principally due to lack of protective vegetative cover.

A relatively isolated gully (an erosion channel that exceeds 1 foot in depth), has formed at the southerly limits of the geogrid-reinforced slope (see Photos 13 and 14). A potential solution to repair this gully and stabilize this area of the bluff is depicted in Figure 8. A geosynthetic such as a three-dimensional cellular confinement system (TDCCS) like Geoweb or TerraCell can be stacked in a stepwise fashion within the bottom of a gully to provide a series of low-height grade control elements that encourage infiltration and reduce channelized velocities within the natural drainage. The toe of each of these stacked structures should be protected with a mattress of a single layer of the TDCCS filled with soil and planted with suitable vegetation (see Figure 8). Portions of the gully between grade control elements should be infilled and covered with a geotextile erosion control blanket to assist in vegetative development and the prevention of erosion until planting is well established. Additional vegetation sites are also located within the exposed step of the stacked TDCCS since soil is physically contained within the cells or elements of this particular type of geosynthetic as it is vertically constructed.

In addition, we recommend that a landscape plan be prepared and implemented to help protect and stabilize the fill slope. Subsequent monitoring surveys will serve to document any changes in what appears to otherwise be a very limited rate of upper-bluff erosion.

We trust this information meets your present needs. If you have any questions or require additional information, please give us a call.

Sincerely,

ENGEO, INC.

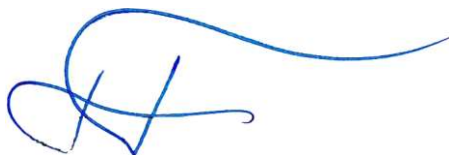

Walter F. Crampton, GE, D.CE
Principal Engineer



Gregory A. Spaulding, CEG
Senior Geologist

wfc/gas/lt/jg

Attachments: Photographs
Figures

REFERENCES

TerraCosta Consulting Group, Inc., August 5, 2014, Proposed Seawall Monitoring Program, 249 Pacific Avenue, Solana Beach, California, Project No. 2530-01 (CDP 6-13-0437).

TerraCosta Consulting Group, Inc., November 22, 2013, Seawall Monitoring Report, 249-311 Pacific Avenue, Solana Beach, California, Project No. 1831H (CDP 6-99-100).

TerraCosta Consulting Group, Inc., June 3, 2005, Seawall Monitoring Report, 249-311 Pacific Avenue, Solana Beach, California, Project No. 1831H (CDP 6-99-100).

TerraCosta Consulting Group, Inc., March 31, 2003, Seawall Baseline Monitoring Report, 249-311 Pacific Avenue, Solana Beach, California, Project No. 1831-3 (CDP 6-99-100).

PHOTOGRAPHS

FIGURES

- Figure 1 – Monitoring Site Plan**
- Figures 2 through 4 – Horizontal Profiles**
- Figures 5 through 7 – Vertical Profiles**
- Figure 8 – Gully Repair**

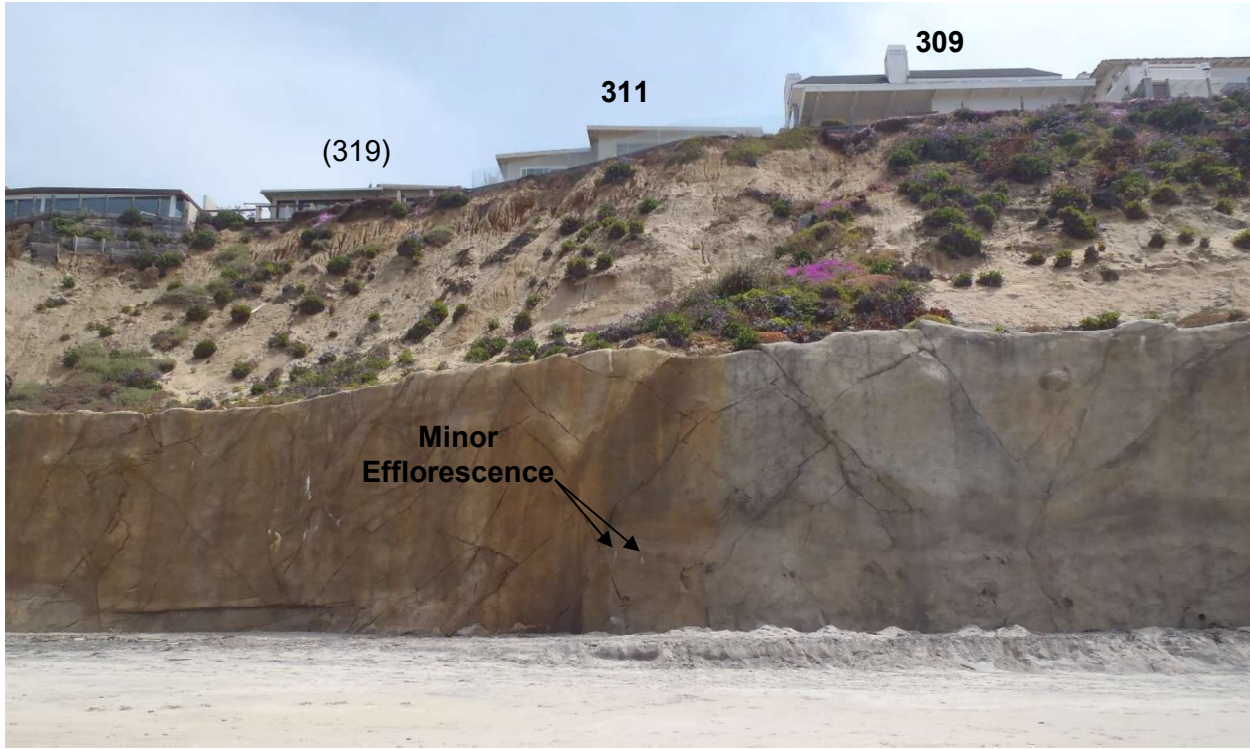

Photo 1: Seawall below 319 to 309 Pacific Avenue (April 26, 2023).

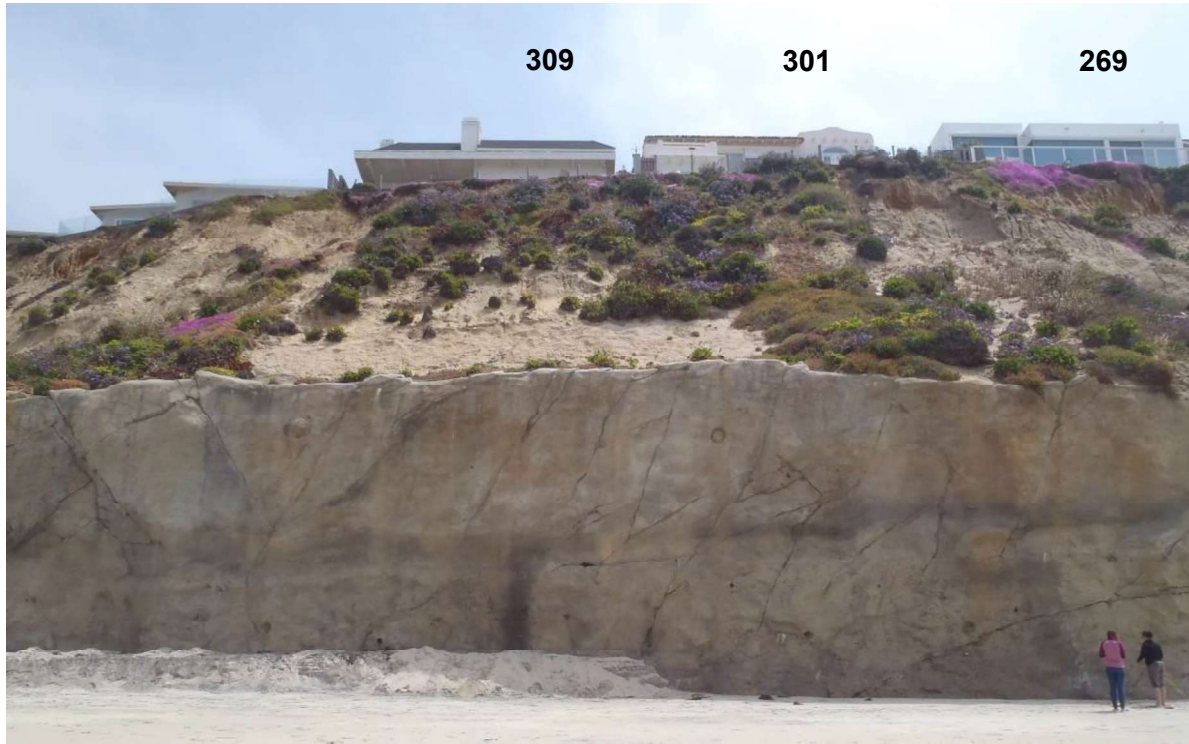

Photo 2: Seawall below 309 to 269 Pacific Avenue (April 26, 2023).

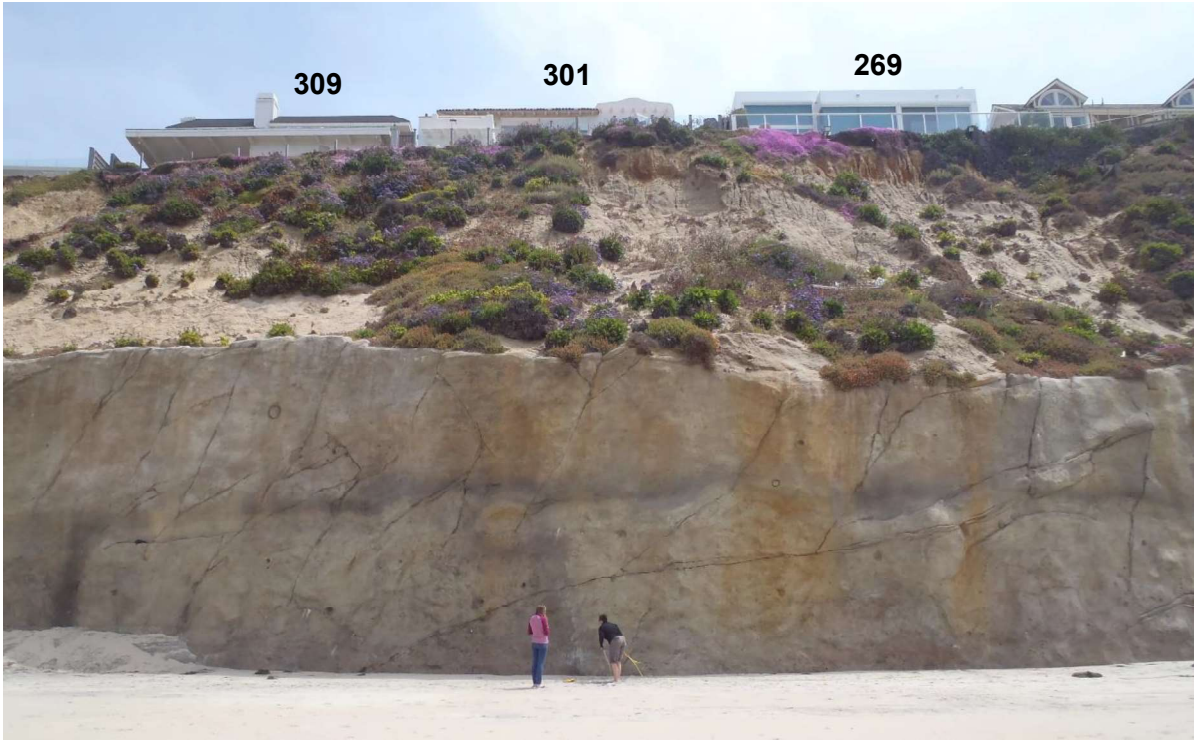

Photo 3: Seawall below 309 to 269 Pacific Avenue (April 26, 2023).



Photo 4: Seawall below 301 to 261 Pacific Avenue (April 26, 2023).

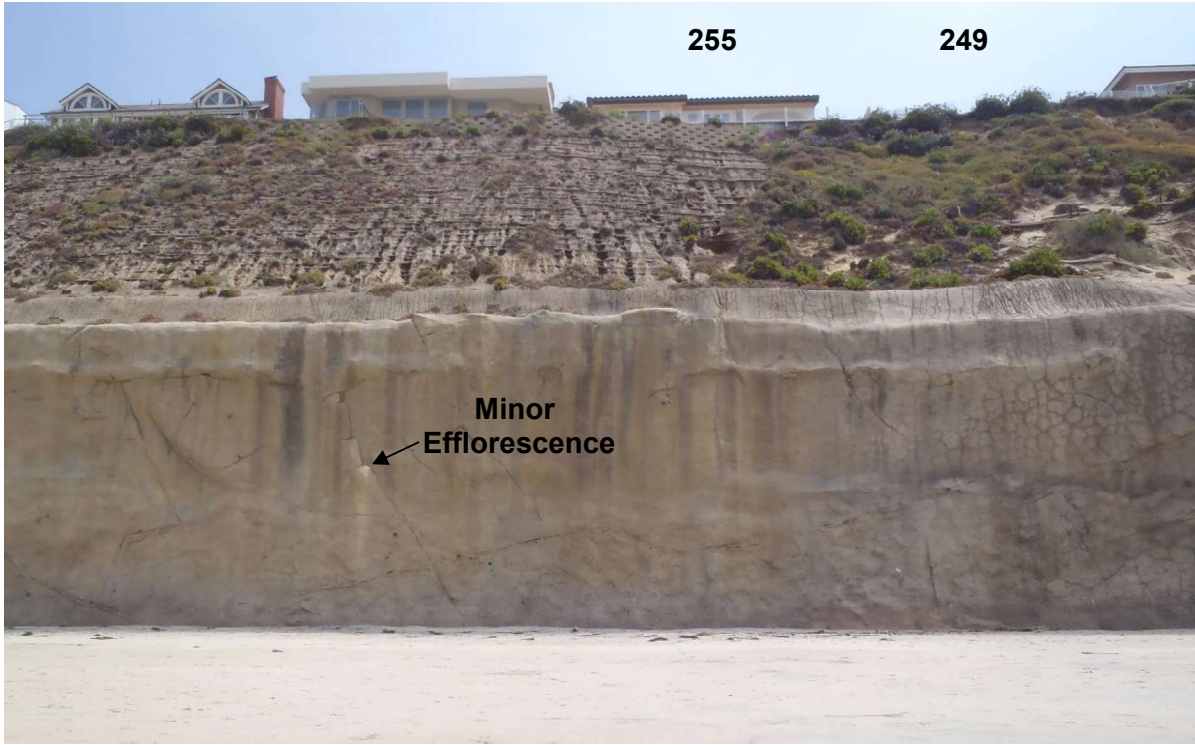

Photo 5: Seawall below 265 to 249 Pacific Avenue (April 26, 2023).



Photo 6: Seawall below 255 to 249 Pacific Avenue (April 26, 2023)



Photo 7: Upper bluff below 311 to 309 Pacific Avenue (November 4, 2013).

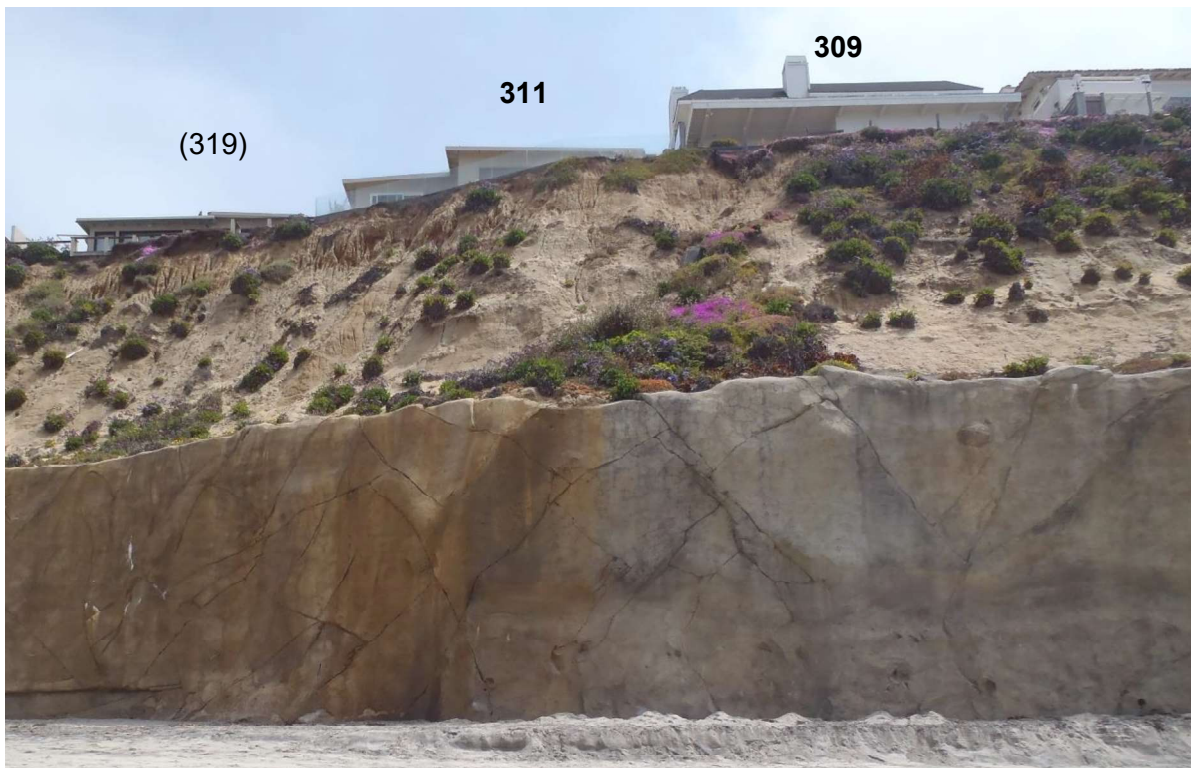

Photo 8: Upper bluff below 311 to 309 Pacific Avenue (April 26, 2023). Signs of only minor erosion in nearly 10 years.



Photo 9: Upper bluff below 309 to 265 Pacific Avenue (November 4, 2013).

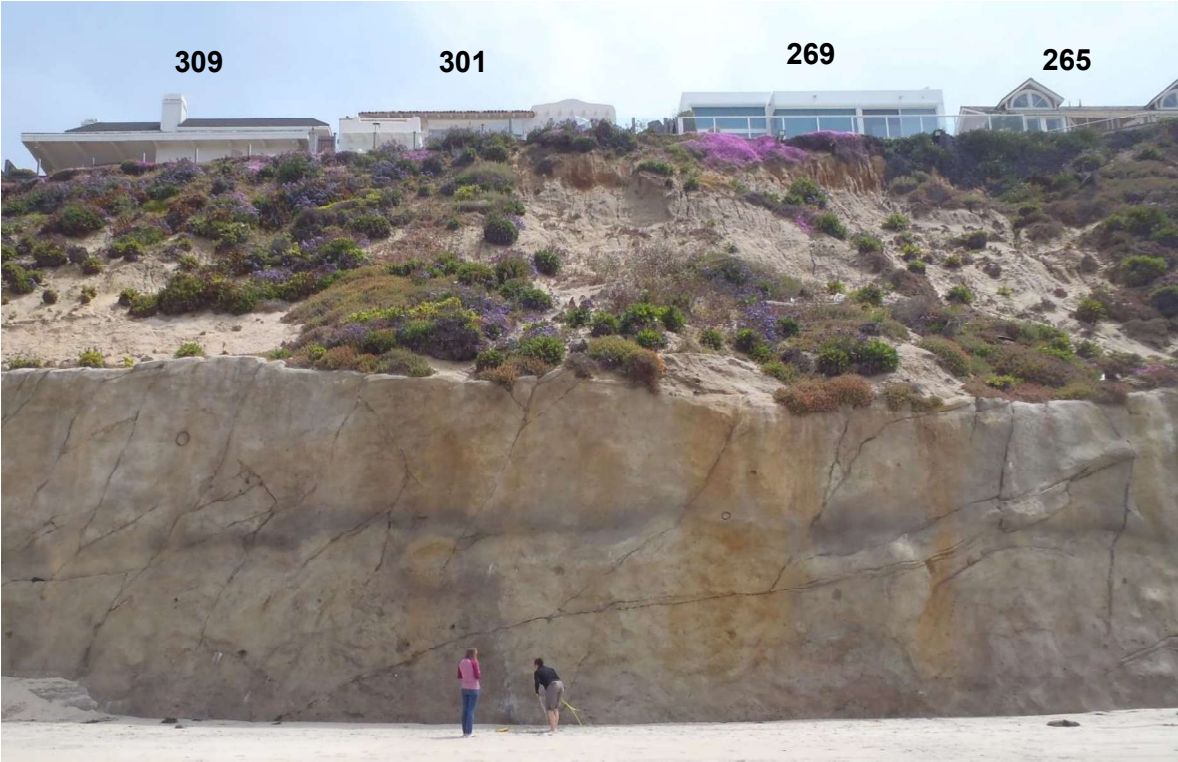

Photo 10: Upper bluff below 309 to 265 Pacific Avenue (April 26, 2023). Upper bluff performing well.



Photo 11: Upper bluff below 265 to 249 Pacific Avenue (November 4, 2013).



Photo 12: Upper bluff below 265 to 249 Pacific Avenue (April 26, 2023). Geogrid-reinforced slope is showing continued rill erosion due in part to lack of vegetative cover.



Photo 13: Geogrid-reinforced slope below 261 to 249 showing signs of deep erosion (April 26, 2023).



Photo 14: Screen shot of large and small erosion gullies below 255 Pacific Avenue provided by property owner drone footage (July 19, 2023).

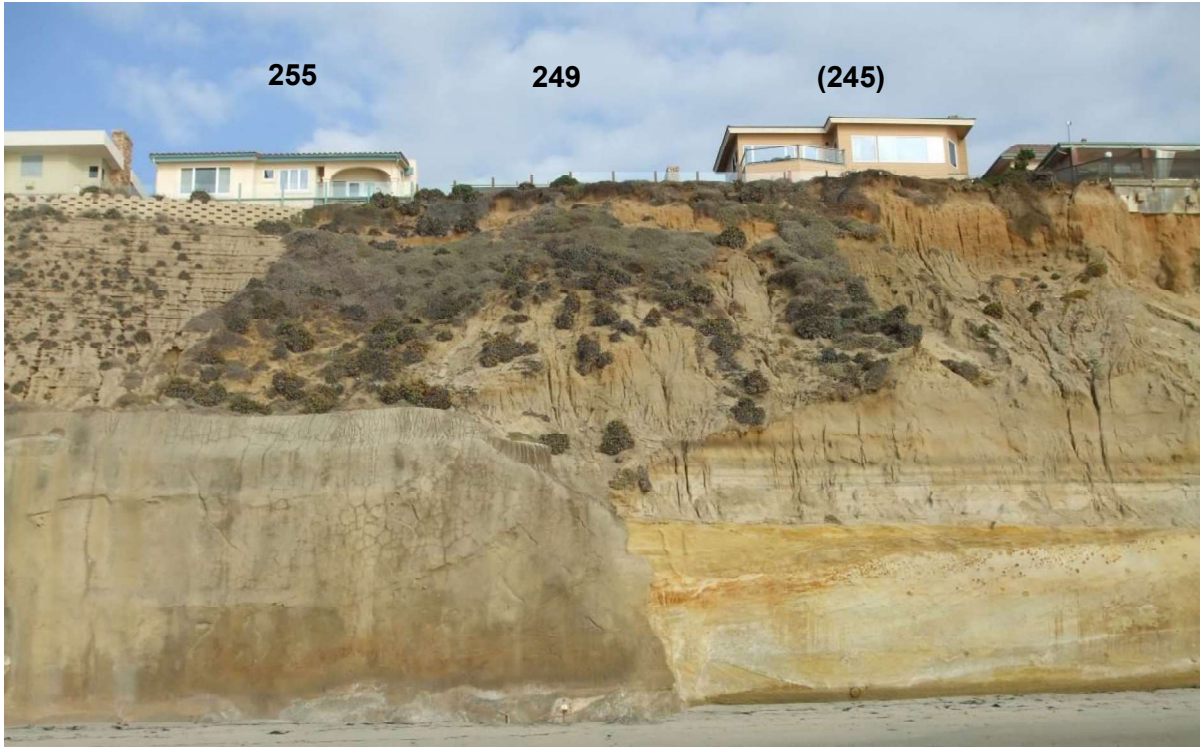

Photo 15: Upper bluff below 255 to 249 (& 245) Pacific Avenue (November 4, 2013).

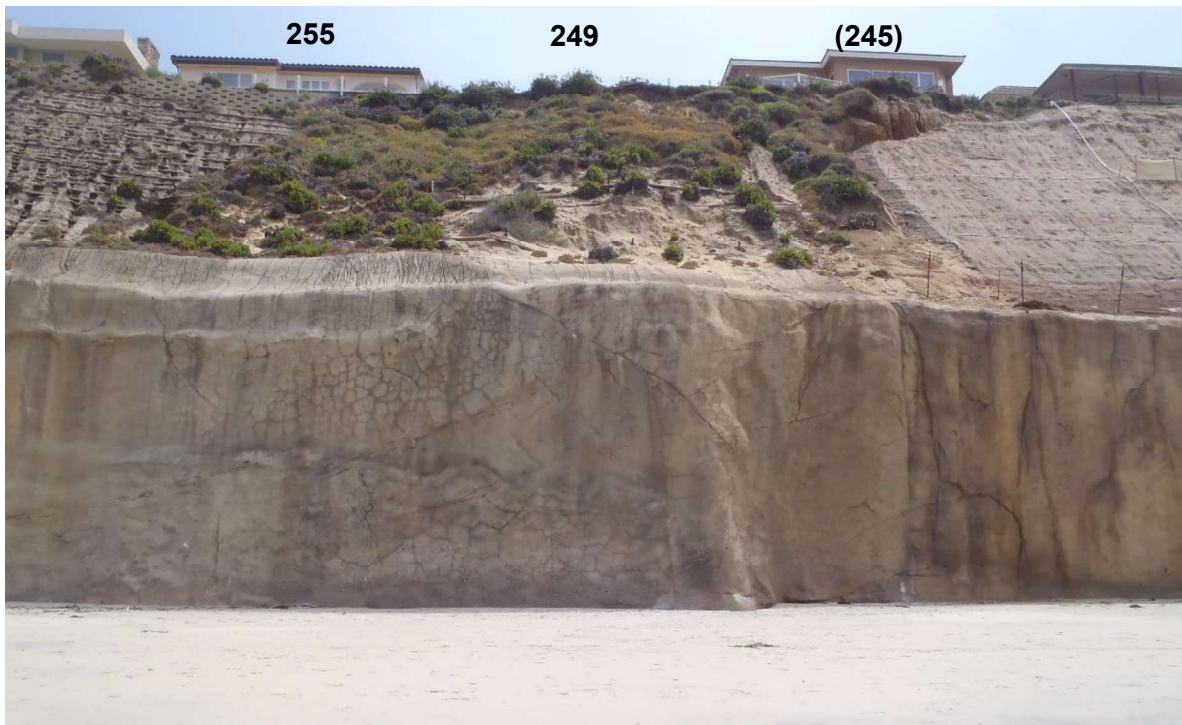

Photo 16: Upper bluff below 255 to 249 (& 245) Pacific Avenue (April 26, 2023).



Photo 17: 249 Pacific Avenue looking south (November 4, 2013).



Photo 18: 249 Pacific Avenue looking south (May 19, 2022).



Photo 19: 255 Pacific Avenue looking south (November 4, 2013).



Photo 20: 255 Pacific Avenue looking south (May 19, 2022).



Photo 21: 261 Pacific Avenue looking north (November 4, 2013).

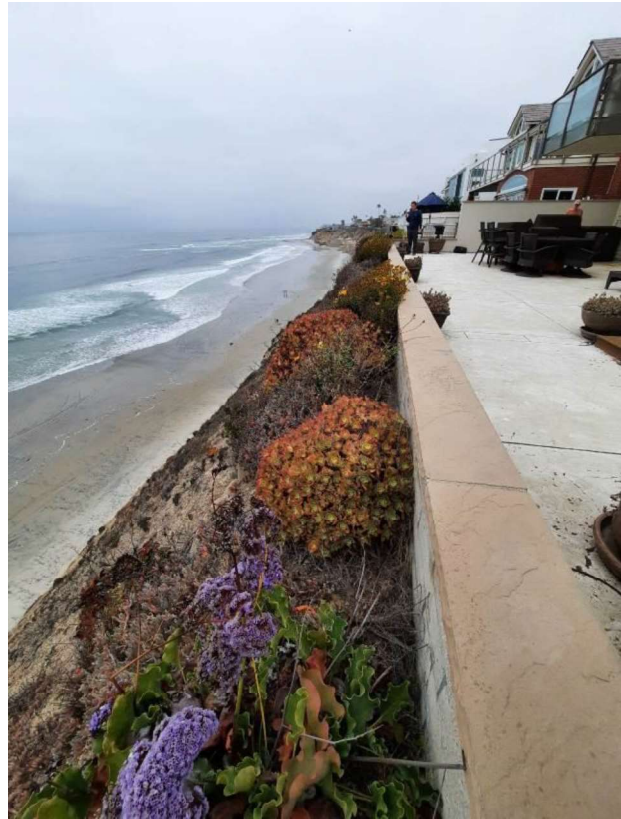

Photo 22: 261 Pacific Avenue looking north (May 19, 2022).



Photo 23: Looking south toward 265 Pacific Avenue upper bluff from 269 Pacific Avenue (November 4, 2013).



Photo 24: Looking south toward 265 Pacific Avenue upper bluff from 269 Pacific Avenue (May 19, 2022).



Photo 25: 269 Pacific Avenue looking north (November 4, 2013).

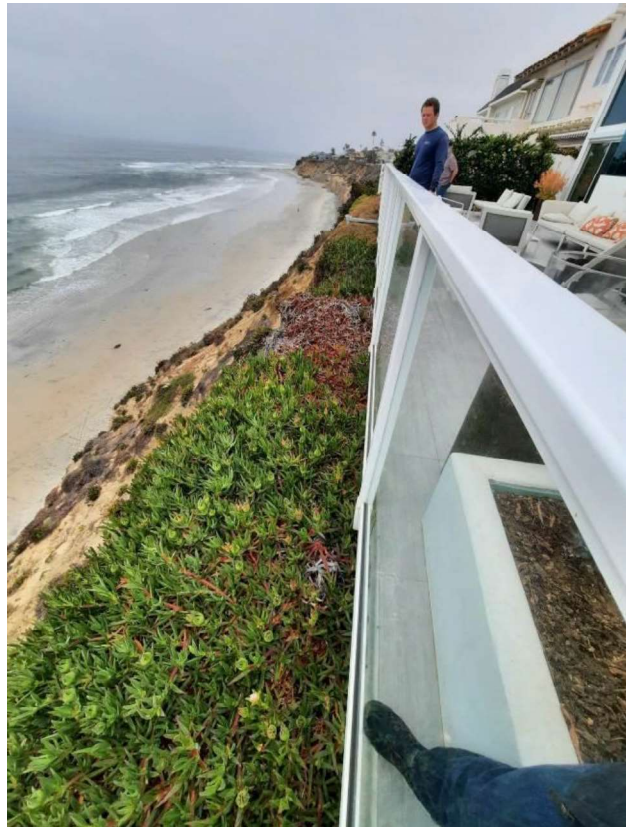

Photo 26: 269 Pacific Avenue looking north (May 19, 2022).



Photo 27: 301 Pacific Avenue looking south (November 4, 2013).

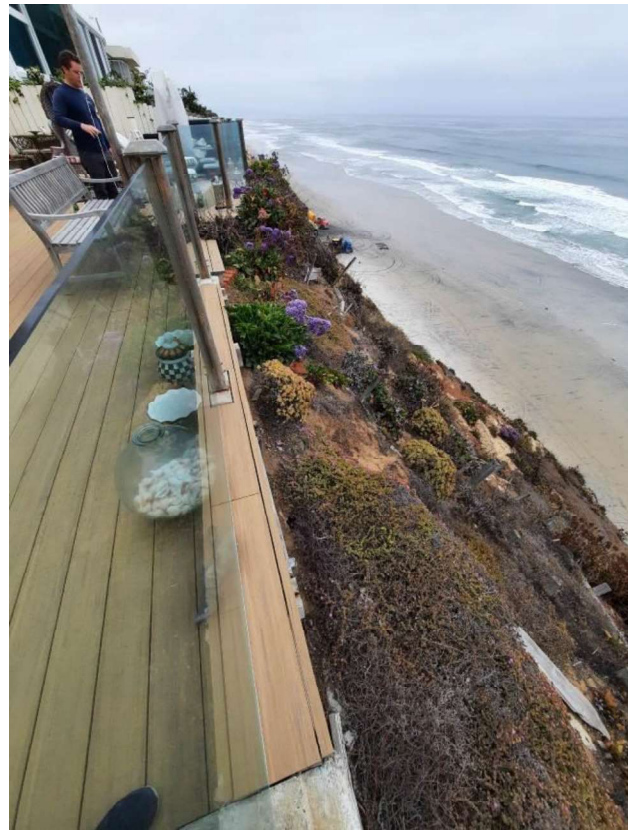

Photo 28: 301 Pacific Avenue looking south (May 19, 2022).



Photo 29: 309 Pacific Avenue looking north (November 4, 2013).



Photo 30: 309 Pacific Avenue looking north (May 19, 2022).



Photo 31: 311 Pacific Avenue looking north (November 4, 2013).

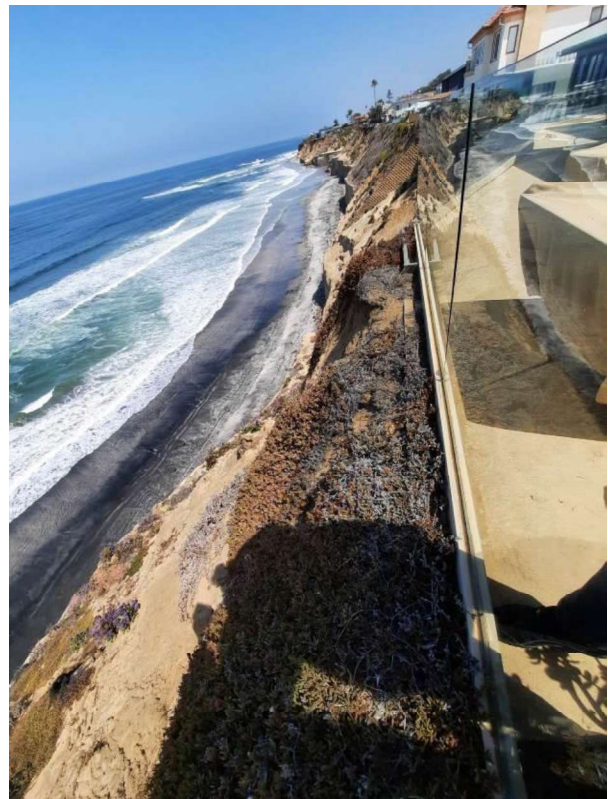
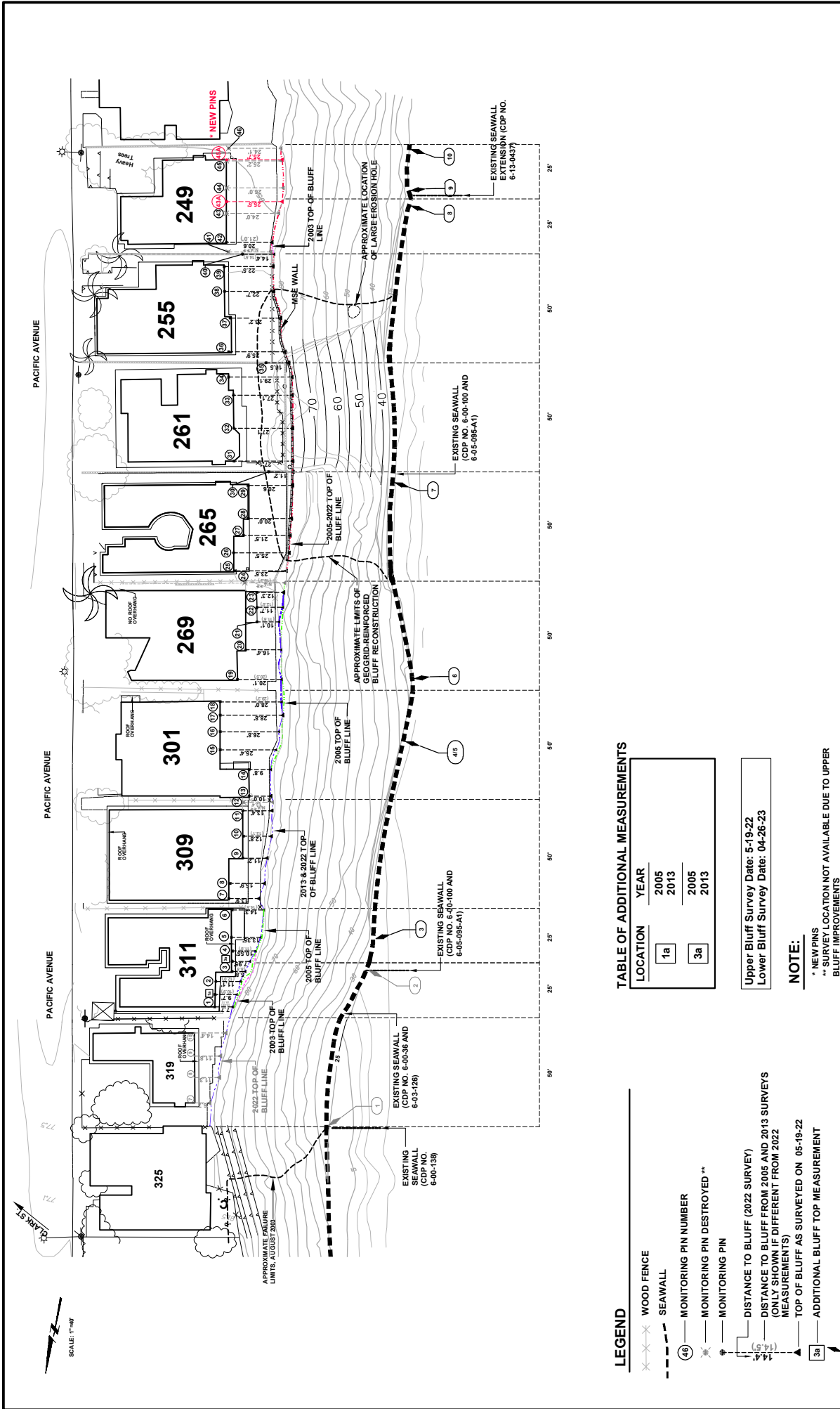

Photo 32: 311 Pacific Avenue looking north (May 19, 2022).



ENGEO
Expect Excellence

MONITORING SITE PLAN
249-311 PACIFIC AVENUE
SOLANA BEACH, CALIFORNIA

PROJECT NO.: T1831-H01.001
SCALE: 1" = 40'
DRAWN BY: LT
CHECKED BY: WC

FIGURE NO. **1**

TABLE OF ADDITIONAL MEASUREMENTS

LOCATION	YEAR
1a	2005 2013
3a	2005 2013

Upper Bluff Survey Date: 5-19-22
Lower Bluff Survey Date: 04-26-23

NOTE:

- * NEW PINS
- ** SURVEY LOCATION NOT AVAILABLE DUE TO UPPER BLUFF IMPROVEMENTS

LEGEND

- WOOD FENCE
- SEAWALL
- ④ MONITORING PIN NUMBER
- ✖ MONITORING PIN DESTROYED **
- ⊕ MONITORING PIN
- DISTANCE TO BLUFF (2022 SURVEY)
- DISTANCE TO BLUFF FROM 2005 AND 2013 SURVEYS (ONLY SHOWN IF DIFFERENT FROM 2022 MEASUREMENTS)
- TOP OF BLUFF AS SURVEYED ON 05-19-22
- ADDITIONAL BLUFF TOP MEASUREMENT
- SEAWALL MONITORING PIN

COPYRIGHT © 2023 BY ENGeo INCORPORATED. THIS DOCUMENT MAY NOT BE REPRODUCED IN WHOLE OR IN PART BY ANY MEANS WHATSOEVER, NOR MAY IT BE QUOTED OR EXCERPTED WITHOUT THE EXPRESS WRITTEN CONSENT OF ENGeo INCORPORATED.

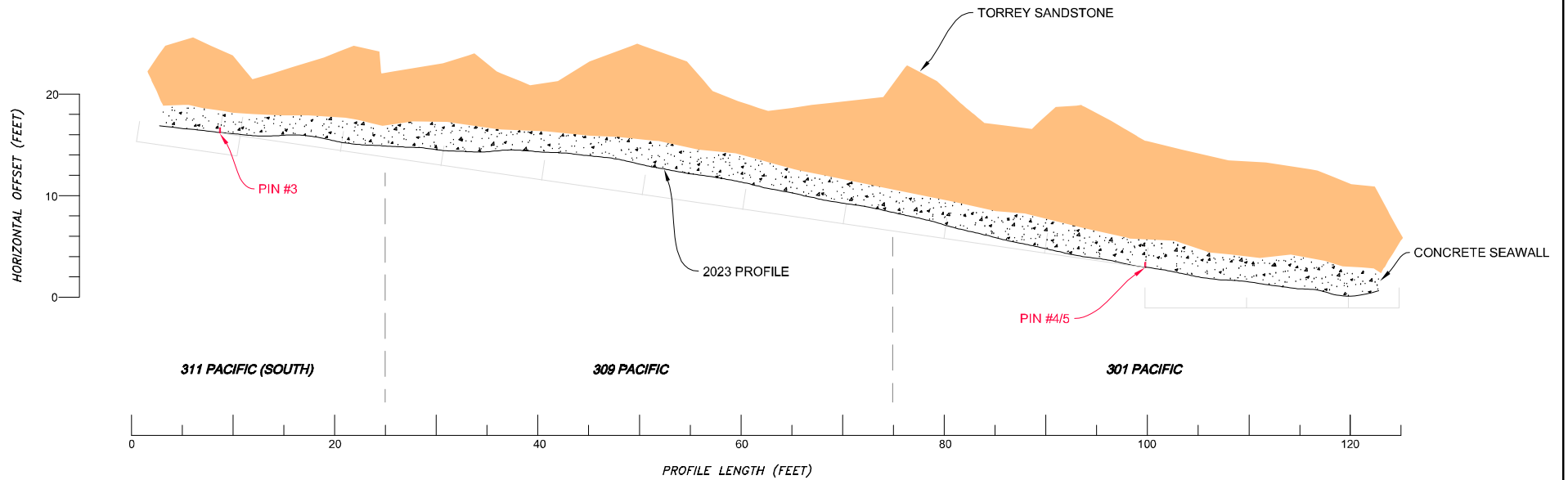

HORIZONTAL SECTION - PROFILE LENGTH
(301 SOUTH TO PIN 4) AT ELEVATION 7.5'± MSL
(301 NORTH / PIN 5 - 311 SOUTH) AT ELEVATION 11.0'± MSL
 (SEAWALL SURVEY DATE 04-26-23)



	HORIZONTAL PROFILE 249-311 PACIFIC AVENUE SOLANA BEACH, CALIFORNIA	PROJECT NO.: T1831.H01.000 SCALE: AS SHOWN	2
		DRAWN BY: LT CHECKED BY: WC	

COPYRIGHT © 2023 BY ENGeo INCORPORATED. THIS DOCUMENT MAY NOT BE REPRODUCED IN WHOLE OR IN PART BY ANY MEANS WHATSOEVER, NOR MAY IT BE QUOTED OR EXCERPTED WITHOUT THE EXPRESS WRITTEN CONSENT OF ENGeo INCORPORATED.

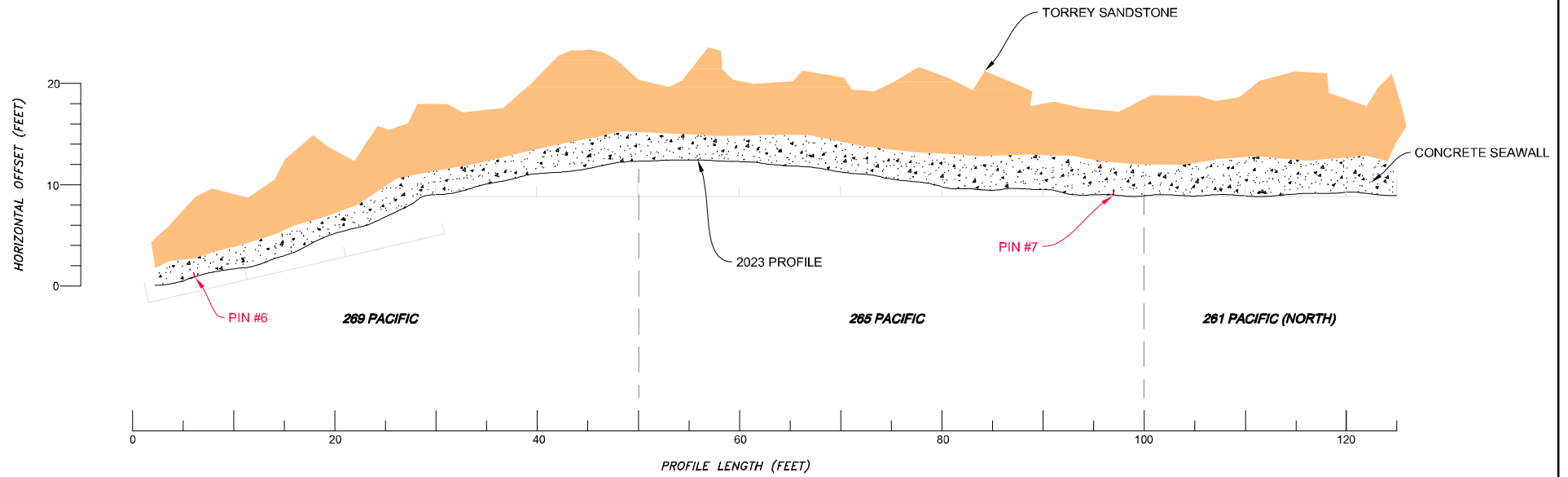

HORIZONTAL SECTION - PROFILE LENGTH (261-269) SEAWALL AT ELEVATION 7.5± MSL
 (SEAWALL SURVEY DATE 04-26-23)

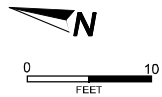

HORIZONTAL PROFILE
 249-311 PACIFIC AVENUE
 SOLANA BEACH, CALIFORNIA

PROJECT NO.:	T1831.H01.000
SCALE:	AS SHOWN
DRAWN BY:	LT
CHECKED BY:	WC

FIGURE NO.
3

COPYRIGHT © 2023 BY ENGeo INCORPORATED. THIS DOCUMENT MAY NOT BE REPRODUCED IN WHOLE OR IN PART BY ANY MEANS WHATSOEVER, NOR MAY IT BE QUOTED OR EXCERPTED WITHOUT THE EXPRESS WRITTEN CONSENT OF ENGeo INCORPORATED.

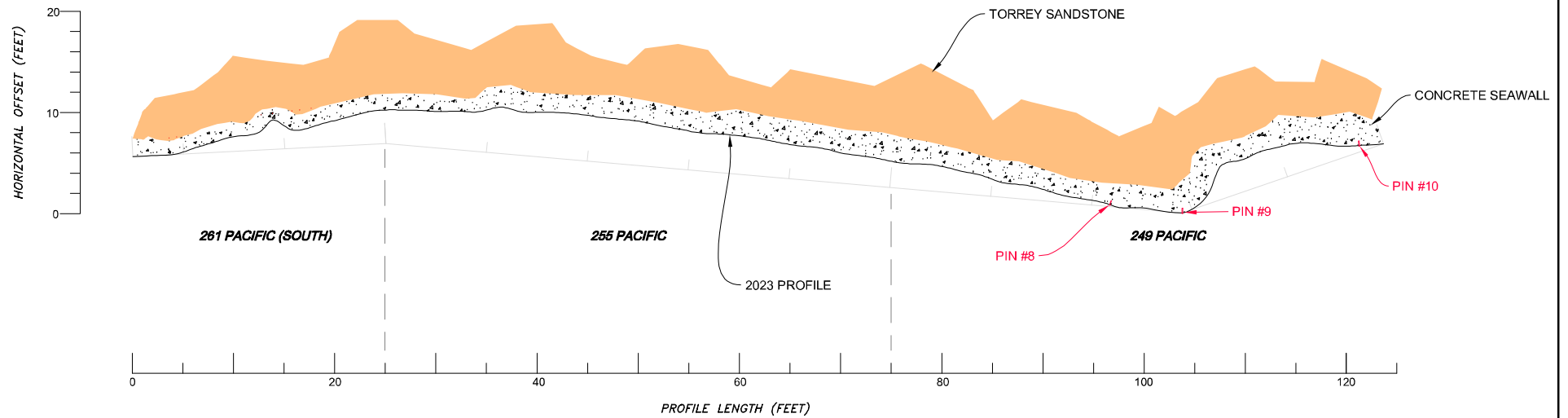

HORIZONTAL SECTION - PROFILE LENGTH SOUTH END SEAWALL AT ELEVATION 7.5± MSL
 (SEAWALL SURVEY DATE 04-26-23)

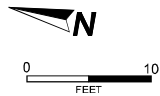

	HORIZONTAL PROFILE 249-311 PACIFIC AVENUE SOLANA BEACH, CALIFORNIA	PROJECT NO.: T1831.H01.000 SCALE: AS SHOWN	4
		DRAWN BY: LT CHECKED BY: WC	

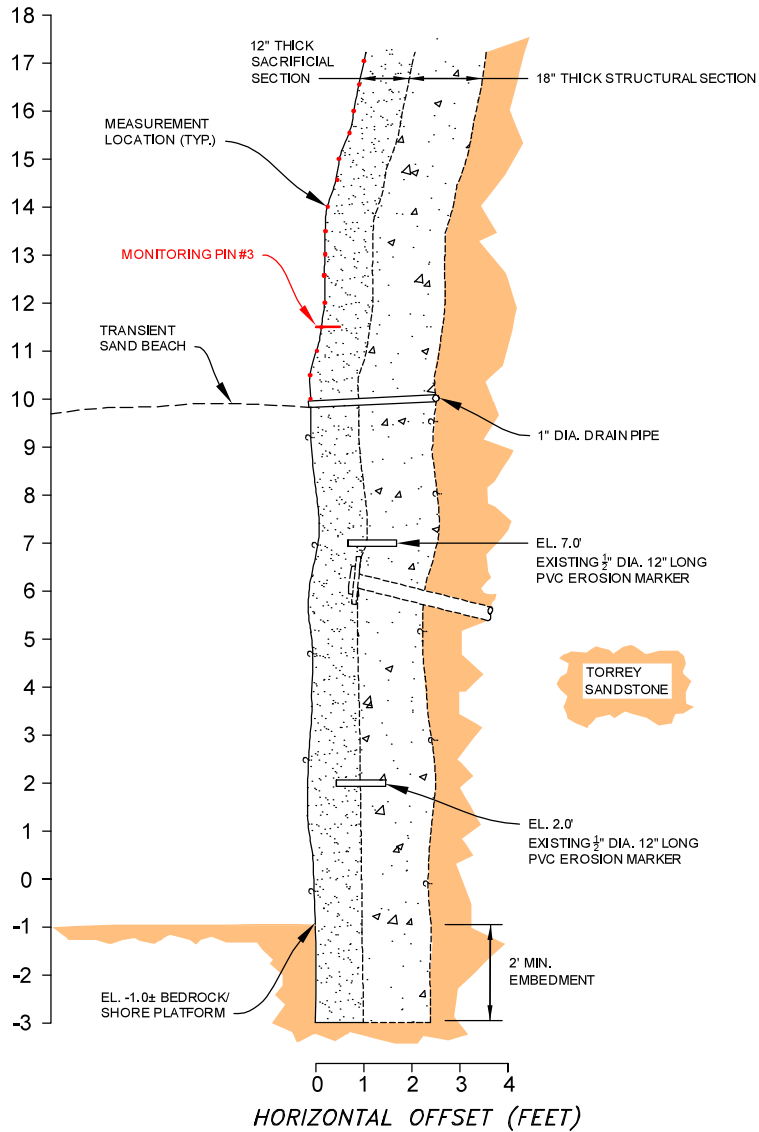

VERTICAL PROFILE @ PIN #3
311 PACIFIC AVENUE (SOUTH)



VERTICAL PROFILE
249-311 PACIFIC AVENUE
SOLANA BEACH, CALIFORNIA

PROJECT NO.: T1831.H01.001

SCALE: AS SHOWN

DRAWN BY: LT

CHECKED BY: WC

FIGURE NO.

5

ORIGINAL FIGURE PRINTED IN COLOR

COPYRIGHT © 2023 BY ENGEO INCORPORATED. THIS DOCUMENT MAY NOT BE REPRODUCED IN WHOLE OR IN PART BY ANY MEANS WHATSOEVER, NOR MAY IT BE QUOTED OR EXCERPTED WITHOUT THE EXPRESS WRITTEN CONSENT OF ENGEO INCORPORATED.

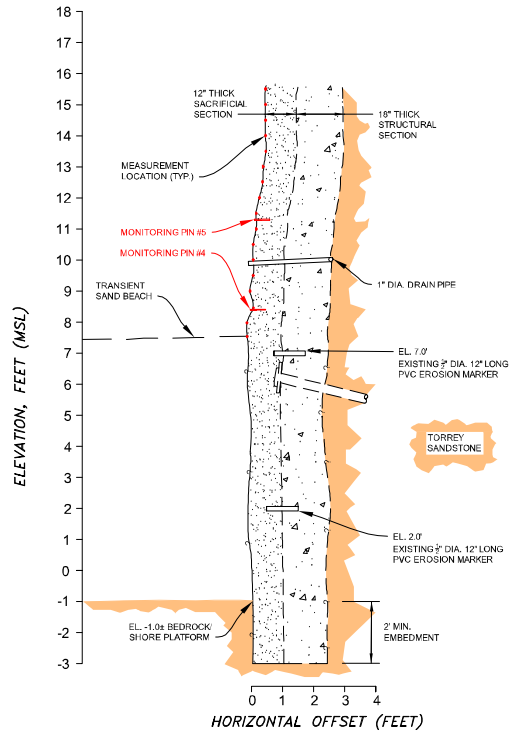

VERTICAL PROFILE @ PINS #4 & #5
 301 PACIFIC AVENUE

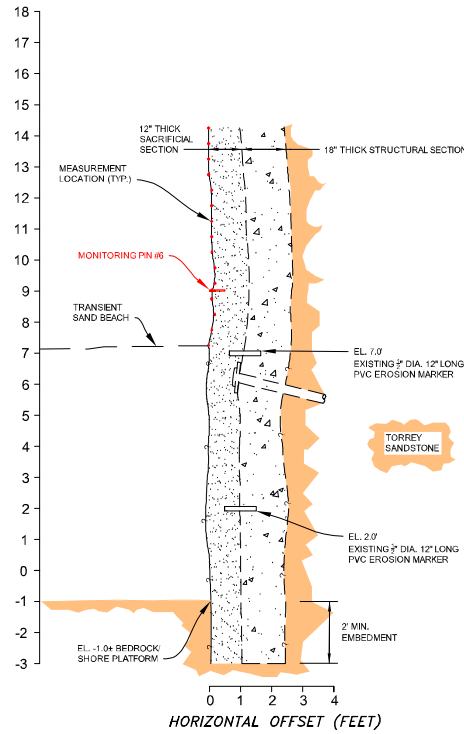

VERTICAL PROFILE @ PIN #6
 269 PACIFIC AVENUE

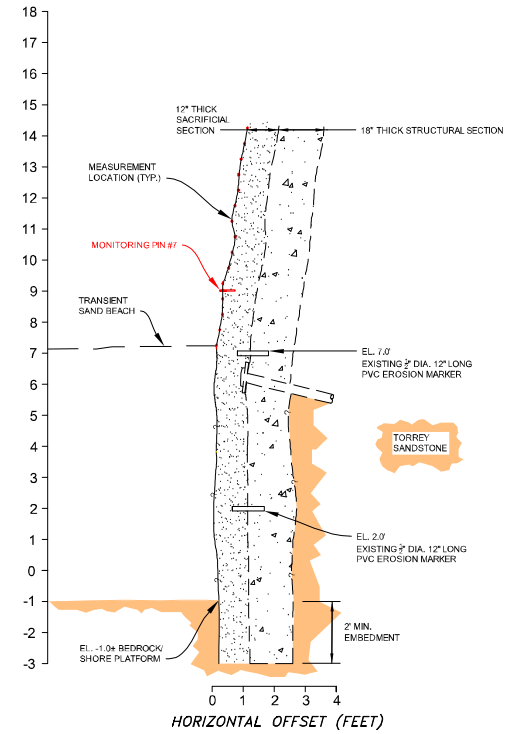

VERTICAL PROFILE @ PIN #7
 265 PACIFIC AVENUE



(SEAWALL SURVEY DATE 04-26-23)



VERTICAL PROFILE
 249-311 PACIFIC AVENUE
 SOLANA BEACH, CALIFORNIA

PROJECT NO.:	T1831H01.001
SCALE:	AS SHOWN
DRAWN BY:	LT
CHECKED BY:	WC

FIGURE NO.
6

ORIGINAL FIGURE PRINTED IN COLOR

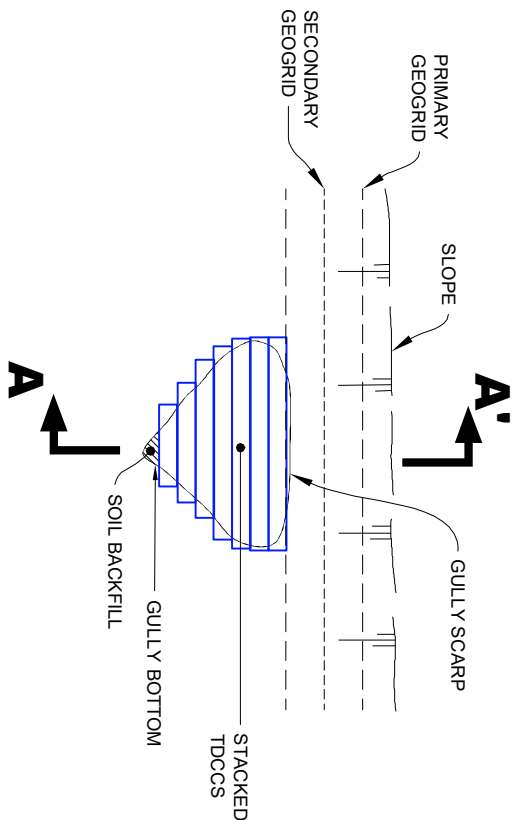

TYPICAL PROFILE OF GULLY REPAIR WITH THREE-DIMENSIONAL CELLULAR CONFINEMENT SYSTEM (TDCCS) CONTROL STRUCTURE

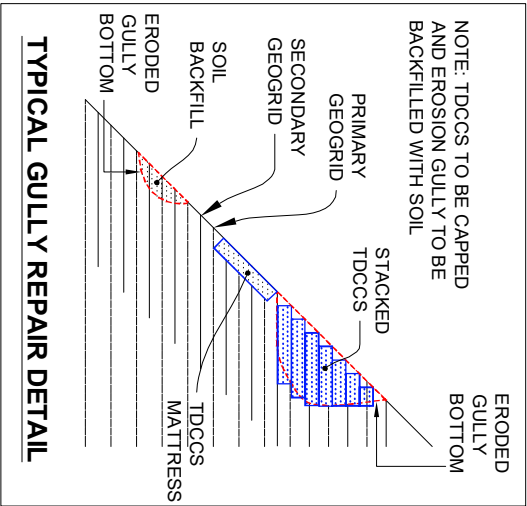

TYPICAL GULLY REPAIR DETAIL

NOTE: FOR THOSE SMALL GULLIES THAT HAVE INTACT GEOGRID EXPOSED IN THE GULLY, BACKFILL THE GULLY WITH SOIL COMPACTED TO 90% OF ASTM D1557 WITH MIRAFI 2XT SECONDARY GEORIDS PLACED IN THE FILL AT 6" VERTICALLY EXTENDING TO THE BACK OF THE GULLY.

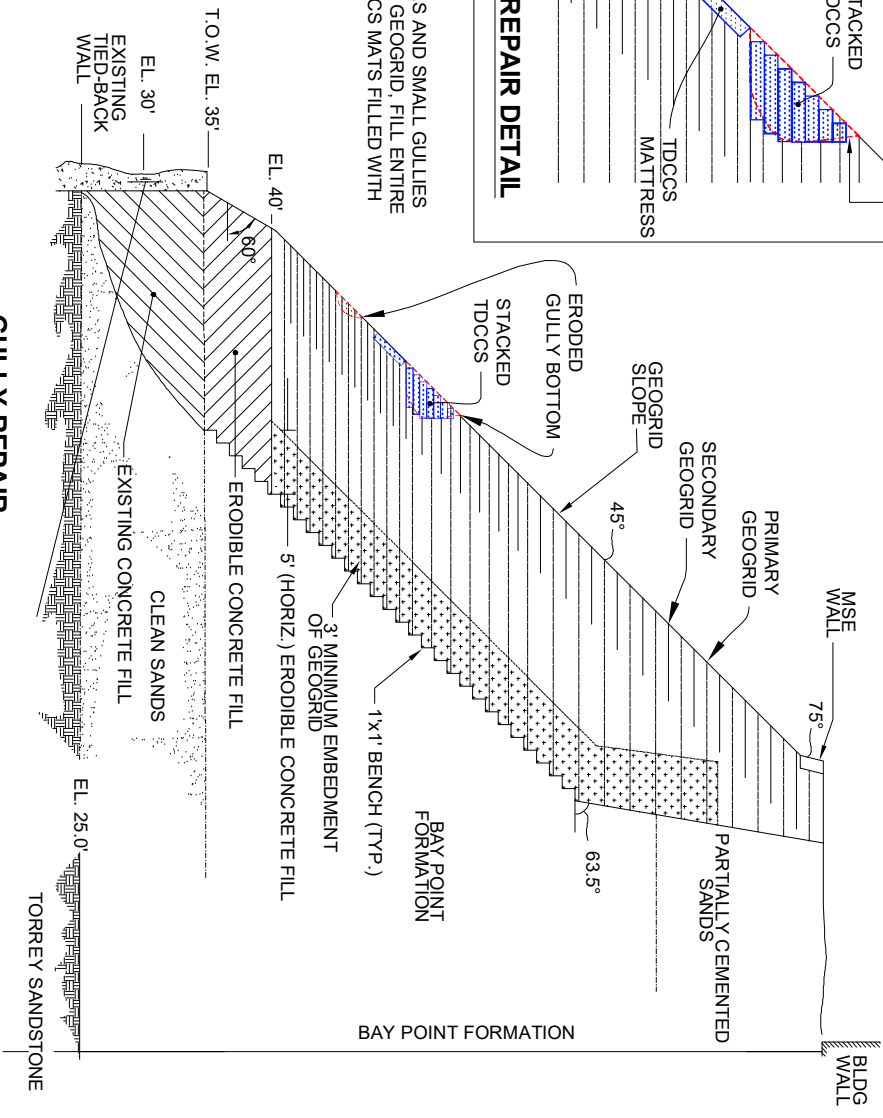

GULLY REPAIR TYPICAL SECTION A-A'

NOTE: FOR LARGER GULLIES AND SMALL GULLIES WITHOUT EXISTING INTACT GEOGRID, FILL ENTIRE GULLY WITH STACKED TDCCS MATS FILLED WITH COMPACTED SOIL.



GULLY REPAIR
249-311 PACIFIC AVENUE
SOLANA BEACH, CALIFORNIA

PROJECT NO.: T1831.H01.001
SCALE: NOT TO SCALE
DRAWN BY: LT

CHECKED BY: W/C

8

FIGURE NO.

ORIGINAL FIGURE PRINTED IN COLOR



BENCH MARK DESCRIPTION: STD 2-1/2" BRASS DISK S D CO ENGR STAMPED "LJ 108 1968" LOCATION: AT SOLANA BEACH ALONG HWY 101 0.5 MILE N OF INTERSECTION OF HWY 101 AND VIA LA VALLE 33 FT E OF CENTERLINE OF HWY 101 82 FT W OF AT AND SFRR TRACKS 24 FEET N OF PROJECTED CENTERLINE OF DAHLIA DRIVE 6 FEET N OF PP JP128081 A COPPER ROD 13.5 FEET DEEP WITH STANDARD DISK STAMPED LJ 108 1968 T145 R4W 02 ELEV. 63.78 DATUM: W.S.L.		SITE PLAN SCALE: 1"=10' COASTAL COMMISSION PERMIT NO. CDP 6-99-100	
SOLANA BEACH FIRE DEPARTMENT By: _____ Fire Chief Date: _____	SANTA FE IRRIGATION DISTRICT By: _____ District Engineer Date: _____	ENGINEER OF WORK RF By: WALTER F. CRAMPTON Date: 03/28/24 Drawn By: _____ R.C.E. 23792 Exp 12/31/25	CITY APPROVED CHANGES APP'D DATE RECOMMENDED FOR APPROVAL By: _____ Date: _____ By: _____ Date: _____ APPROVED FOR CONSTRUCTION By: Mohammad Sammak, City Engineer R.C.E. 37146 Exp 06-30-24

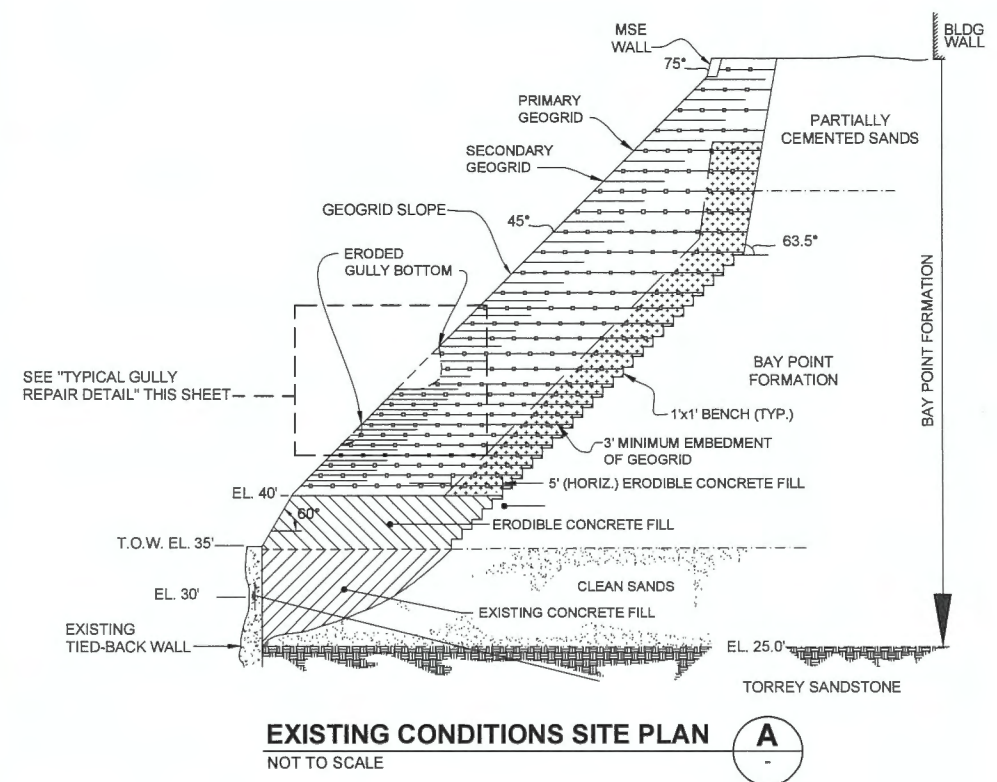

EXISTING CONDITIONS SITE PLAN (A)
NOT TO SCALE

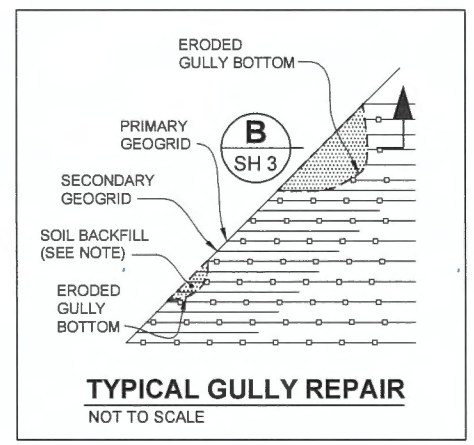

TYPICAL GULLY REPAIR
NOT TO SCALE

NOTE:
FOR THOSE SMALL GULLIES THAT HAVE INTACT GEOGRID EXPOSED IN THE GULLY, BACKFILL THE GULLY WITH SOIL COMPACTED TO 90% OF ASTM D1557 WITH MIRAFI 2XT SECONDARY GEOGRIDS PLACED IN THE FILL AT 6" VERTICALLY EXTENDING TO THE BACK OF THE GULLY.

ENGEO
Expect Excellence
3890 MURPHY CANYON ROAD
SUITE 200
SAN DIEGO, CALIFORNIA 92123
(658) 573-6900



CITY OF SOLANA BEACH ENGINEERING DEPARTMENT GRADING SITE PLAN & CROSS SECTION FOR 255, 261, & 265 PACIFIC AVENUE BLUFF REVEGETATION		DRAWING NO. SBGR- SHEET 2 OF 8
--	--	---

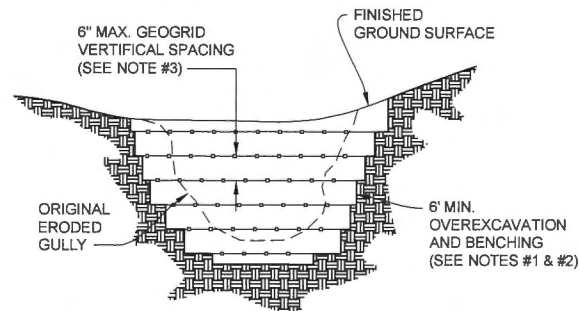

SURFICIAL EROSION GULLY REPAIR **B**
NOT TO SCALE

GULLY REPAIR NOTES:

- OVEREXCAVATE EXISTING EROSION GULLY A MINIMUM OF 6 INCHES, OR UNTIL FIRM SOILS ARE ENCOUNTERED.
- BENCH GULLY EROSION IN 6-INCH STEPS TO ACCOMMODATE PROGRESSIVE GEOGRID LAYERING.
- BACKFILL GULLY WITH COMPACTED FILL SOILS. FILL MATERIALS SHALL BE AS INDICATED IN "REINFORCED EARTH FILL MATERIALS" NOTES ON THIS SHEET.
- DURING BACKFILL OPERATIONS, INSTALL GEOGRIDS AT A MAXIMUM 6" VERTICAL SPACING. SEE "CONSTRUCTION SEQUENCE FOR SLOPE REPAIR" NOTES ON THIS SHEET.

SITE SAFETY

THE CONTRACTOR IS ADVISED THAT THE UPPER BLUFFS, THE CLEAN SANDS ABOVE ELEVATION 25 FEET, ARE HIGHLY UNSTABLE AND SUBJECT TO PROGRESSIVE FAILURES, WITH THE POTENTIAL FOR TENS TO HUNDREDS OF YARDS OF BLUFF-TOP MATERIALS TO COLLAPSE WITH LITTLE, IF ANY, WARNING. PAST FAILURES HAVE BEEN TRIGGERED BY THE VIBRATION INDUCED FROM LOW-FLYING HELICOPTERS TRANSITING THE COASTLINE, AND CORMORANTS PERCHING ON THE SMALL SHELF THAT IS NOW DEVELOPING AT THE GEOLOGIC CONTACT WITH THE UNDERLYING CLIFF-FORMING TORREY SANDSTONE. SUFFICE TO SAY A HAZARDOUS CONDITION EXISTS FOR CONSTRUCTION WORKERS WORKING AT THE BASE OF THE SEA CLIFF. THE CONTRACTOR IS RESPONSIBLE FOR IMPLEMENTING WHATEVER SAFETY PRECAUTIONS HE DEEMS NECESSARY TO MINIMIZE THIS HAZARD.

REINFORCED EARTH FILL MATERIALS

- EXCEPT AS OTHERWISE INDICATED BELOW, UNCLASSIFIED FILL SHALL CONFORM TO THE REQUIREMENTS OF SSPWC SECTION 300-4.
- CLODS OR HARD LUMPS OF EARTH SHALL BE BROKEN UP BEFORE COMPACTING THE MATERIAL IN THE FILL.
- MATERIALS FOR COMPACTED FILL SHALL CONSIST OF ANY ONSITE OR IMPORTED MATERIAL THAT, IN THE OPINION OF THE ENGINEER, IS SUITABLE FOR USE IN CONSTRUCTING FILLS. THE MATERIAL SHALL CONTAIN NO ROCKS OR HARD LUMPS GREATER THAN 6 INCHES IN SIZE AND SHALL CONTAIN AT LEAST 40% OF MATERIAL SMALLER THAN 1/4 INCH IN SIZE. ROOTS, TREE BRANCHES AND OTHER MATTER MISSED DURING CLEARING, SHALL BE REMOVED FROM THE FILL AS DIRECTED BY THE ENGINEER.
- SILT PLUS CLAY CONTENT OF THE UNCLASSIFIED FILL IS NOT TO EXCEED 40% BY WEIGHT. CLAY CONTENT SHALL NOT BE LESS THAN 10% BY WEIGHT, AND NO MORE THAN 5% SHALL BE RETAINED ON THE 2.0 MM SIEVE.
- THE SOIL SHALL HAVE A COHESION OF 100 PSF MINIMUM AND A MINIMUM PHI OF 33 DEGREES.
- THE PLASTICITY INDEX (P.I.), AS DETERMINED BY THE ASTM D-4318, SHALL NOT EXCEED 25.
- ALL FILL SHALL BE COMPACTED TO A MINIMUM RELATIVE COMPACTION OF 90%.

FILL NOT CONFORMING TO THESE SPECIFICATIONS SHALL NOT BE USED WITHOUT THE WRITTEN CONSENT OF THE ENGINEER.

THE FREQUENCY OF SAMPLING OF UNCLASSIFIED FILL, NECESSARY TO ASSURE GRADATION CONTROL AND ALL SUPPLEMENTAL REQUIREMENTS OUTLINED ABOVE THROUGHOUT CONSTRUCTION, SHALL BE AS DIRECTED BY THE ENGINEER.

CONSTRUCTION SEQUENCE FOR SLOPE REPAIR

- PLACE GEOGRIDS (2XT) FLAT ON LEVEL GROUND AND EXTEND TO THE FULL AVAILABLE EMBEDMENT LENGTH. THE FRONT ENDS OF THE GEOGRIDS SHOULD EXTEND BEYOND FINISHED SLOPE LINE, AND THEN TRIMMED TO MATCH SLOPE.
- PLACE BACKFILL ON TOP OF GEOGRIDS AND COMPACT TO A MINIMUM OF 90% RELATIVE COMPACTION UNTIL COMPACTED LIFT EQUALS THAT SHOWN ON THE CONSTRUCTION DRAWINGS.
- PLACE NEXT LAYER OF GEOGRIDS FLAT ON LEVEL GROUND AND EXTEND TO THE FULL AVAILABLE LENGTH. THE FRONT ENDS OF THE GEOGRIDS SHOULD EXTEND BEYOND FINISHED SLOPE LINE, AND THEN TRIMMED TO MATCH SLOPE.
- FILL MATERIAL ALONG THE FRONT FACE OF THE SLOPE SHOULD BE COMPACTED AND GRADED TO MATCH THE SURROUNDING BLUFF SURFACE.
- REPEAT STEPS 2 THROUGH 5 UNTIL GULLY IS COMPLETELY FILLED.

PROCESS OF RECONSTRUCTION

- ACCESS AND SITE PREPARATION
 - ACCESS TO THE CONSTRUCTION AREA WILL BE FACILITATED THROUGH THE HOMEOWNERS' YARDS AT THE TOP OF THE BLUFF.
 - FILL SOILS WILL BE TRANSFERRED TO THE BACKYARD FOR TRANSPORTATION TO THE GULLY AREA.
 - INSTALLATION OF A 12" DIAMETER PVC PIPE CHUTE (CUT IN HALF) FOR SOIL TRANSPORT FROM THE TOP OF THE BLUFF TO THE CONSTRUCTION SITE.
 - LADDERS WILL BE PLACED ALONG THE SLOPE FACE TO FACILITATE SAFE MOVEMENT ON, AND MINIMIZE DAMAGE TO THE FACE OF THE BLUFF.
 - CONSTRUCTION AND PLANTING MATERIALS WILL BE HAND CARRIED TO AND FROM THE SLOPE.
- EXCAVATION AND STABILIZATION
 - THE RECONSTRUCTION WILL COMMENCE WITH THE EXCAVATION FOR THE LOWEST SECTION OF THE GULLY.
 - VERTICAL AND HORIZONTAL KEYWAYS WILL BE CREATED TO ENHANCE STABILITY.
 - GEOGRID WILL BE STRATEGICALLY PLACED ON THE EXCAVATED SECTION, EXTENDING TO THE BACK OF THE BENCHING.
 - EXCAVATED SOIL WILL BE UTILIZED TO FILL THE SECTION ATOP MECHANICALLY STABILIZED EARTH (MSE).
 - ANY ADDITIONAL DIRT REQUIRED WILL BE TRANSPORTED VIA THE PVC CHUTE.
 - SIMILAR EXCAVATION AND STABILIZATION PROCEDURES WILL BE CONDUCTED IN SECTIONS MOVING UP THE SLOPE.
 - THE PROCESS WILL CONTINUE UNTIL REACHING THE TOP OF THE ERODED SLOPE.
 - ANY SURPLUS SOIL WILL BE MANAGED BY A TEAM MEMBER, WHO WILL MOBILIZE TO CLEAR A SPACE ON THE BEACH FOR DISPOSAL.
- TEMPORARY IRRIGATION INSTALLATION
- PERFORM WEED CONTROL
 - IRRIGATE FOR A PERIOD OF TWO WEEKS OR UNTIL WEED HEIGHT EXCEEDS 2 TO 3 INCHES.
 - APPLY ROUND UP.
 - REMOVE ALL WEEDS.
- HYDROSEED APPLICATION
 - SPRAY APPLY HYDROSEED SLURRY.
 - PERFORM GERMINATION STAGE IRRIGATION.
- PLANTING
 - EXCAVATE PITS TO RECEIVE PLANTS.
 - PLACE PLANTS INTO PREPARED PITS AND BACKFILL.
 - APPLY INITIAL IRRIGATION AND FERTILIZER MIX.
 - SMOOTH PLANTING AREAS
- RESTORATION AND CLEANUP
 - REMOVE EXCESS DEBRIS AND SPOILS.
 - SMOOTH PLANTING AREAS.

BENCH MARK
DESCRIPTION: STD 2-1/2" BRASS DISK S D CO ENGR STAMPED "LJ 108 1988"
LOCATION: AT SOLANA BEACH ALONG HWY 101 0.5 MILE N OF INTERSECTION OF HWY 101 AND VIA LA VALLE 53 FT E OF CENTERLINE OF HWY 101 82 FT W OF AT AND SPRR TRACKS 34 FEET N OF PROJECTED CENTERLINE OF DANLIA DRIVE 6 FEET N OF PP JP-129001 A COPPER ROD 12.5 FEET DEEP WITH STANDARD DISK STAMPED "LJ 108 1988 T145 R4W 02 ELEV. 62.78 DATUM W.S.L.

COASTAL COMMISSION PERMIT NO. **CDP 6-99-100**

SOLANA BEACH FIRE DEPARTMENT	SANTA FE IRRIGATION DISTRICT	ENGINEER OF WORK	CITY APPROVED CHANGES	APPD DATE	RECOMMENDED FOR APPROVAL	APPROVED FOR CONSTRUCTION	BENCH MARK	CITY OF SOLANA BEACH	ENGINEERING DEPARTMENT	DRAWING NO
By _____ Fire Chief Date _____	By _____ District Engineer Date _____	RF Drawn By By WALTER F. CRAMPTON Date 03/28/24 R.C.E. 23792 Exp 12/31/25			By _____ Date _____	By _____ Date _____ Mohammad Sammak, City Engineer R.C.E. 37146 Exp 06-30-24	SEE DETAILED BLOCK ABOVE LEFT	GRADING GULLY REPAIR DETAIL & NOTES FOR 255, 261, & 265 PACIFIC AVENUE BLUFF REVEGETATION		SBGR- SHEET 3 OF 8

ENGEO
Expect Excellence
3890 MURPHY CANYON ROAD
SUITE 200
SAN DIEGO, CALIFORNIA 92123
(858) 573-6900



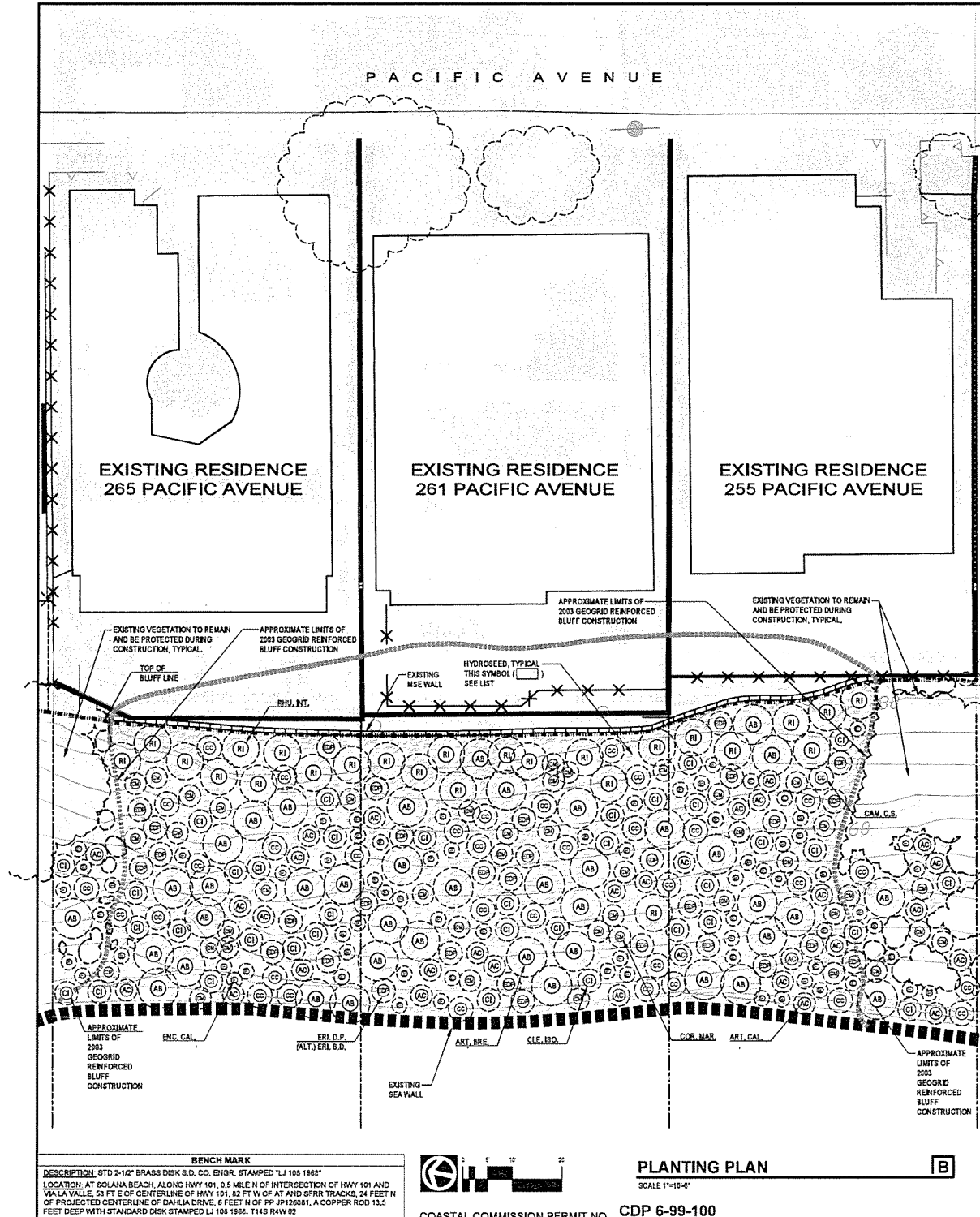

HYDROSEED MIX

SCIENTIFIC OR PRODUCT NAME	COMMON NAME	P.L.S.	RATE/ACRE	SEEDS/LB.
BINDER	AZTEC™ OR APPROVED EQUAL		225 LBS.	
FERTILIZER	TR-C 6-2-4		500 LBS.	
MULCH	VIRGIN WOOD FIBER		3000 LBS.	
AMBROSIA VILLOSA	SAND VERBENA	15%	1 LBS.	15,000
AMBRASIA CHAMISSONIS	BEACH BUR	42%		40,000
ARTEMISIA CALIFORNICA	COASTAL SAGEBRUSH	9%	3 LBS.	55,000,000
CAMISSONIA CHERANTHIFOLIA SSP. SUFRUTICOSA	SUN CUP (BEACH EVENING PRIMROSE)	72%	1/2 LBS.	4,000
CLEOME ISOMERIS	BLADDER POD	60%	5 LBS.	4,000
COREOPSIS MARITIMA	SAN DIEGO SEA DAHLIA	2 LBS.		
CORETHROGYNE FLANGIFOLIA SSP. LINFOLIA	DEL MAR MESA SAND ASTER	1 1/2 LBS.		940,000
ENCELLA CALIFORNICA	CALIFORNIA ENCELLA	24%	8 LBS.	175,000
ERIOGONUM FASCICULATUM	CALIFORNIA BUCKWHEAT	7%	10 LBS.	450,000
LASTHENIA CALIFORNICA	DWARF GOLDFIELDS	0.30%	1-1/2 LBS.	3,250,000
LASTHENIA GLABRA	GOLDFIELDS	77%	1-1/2 LBS.	1,800,000
LUPINUS BICOLOR	PYGMY-LEAFED LUPINE	7%	5 LBS.	115,000
MIMULUS PUNICEUS	MONKEY FLOWER	1%	1-1/2 LBS.	1,200,000
SARVON™			20Z/100 GALS OF HYDROSEED SLURRY	8 GALS.
SUPERTHRIVE™			1800 LBS.	
ADD GYPSUM OR FLOWABLE GYPSUM TO THE MIX AND CONFIRM BEFORE APPLICATION			40 OZ.	
MYCORRHIZAL INOCULUM, OLONIS INTRARADICES				

- #### HYDROSEED NOTES:
- NP.L.S. = % PURITY TIMES % GERMINATION OF SEED. THIS INDICATES THE MINIMUM PERCENTAGE OF PURITY OF THE SEED TO BE PROVIDED.
 - THE SEED COMPANY SHALL APPLY ALL SEED WITHIN ONE YEAR OF COLLECTION.
 - HYDROSEEDING WILL BE MOST EASILY ESTABLISHED, IF APPLIED BETWEEN OCTOBER 15 AND JANUARY 15.
 - ADDITIONAL RATES OF MULCH AND BINDER HAVE BEEN SPECIFIED TO BE ADEQUATE FOR THE STEEPNESS OF SLOPE.
 - CONTRACTOR IS ADVISED THAT THE ACTUAL AREA (ON SLOPE) FOR THIS PROJECT IS APPROXIMATELY 141% LARGER THAN THE AREA SHOWN IN THE PLAN VIEW. SEED, MULCH AND BINDER AND FERTILIZER AMOUNTS SHALL BE COMMENSURATE WITH THIS ACTUAL SLOPE AREA. (NOT THE PLANIMETRIC AREA.)
- #### PLANTING NOTES
- ALL VEGETATION PLANTED ON THE SITE SHALL CONSIST OF NATIVE, DROUGHT TOLERANT SPECIES, NON INVASIVE PLANTS. ALL HYDROSEEDING ON THE APPROX. 1:1 SLOPE CONSISTS OF SPECIES NATIVE TO THE SAN DIEGO COUNTY COASTAL BLUFFS.
 - ALL PLANTING SHALL BE COMPLETED WITHIN 90 DAYS OF THE CONSTRUCTION OF THE BLUFF.
 - ALL REQUIRED PLANTINGS WILL BE MAINTAINED IN GOOD GROWING CONDITION THROUGHOUT THE LIFE OF THE PROJECT, AND, WHENEVER NECESSARY, SHALL BE REPLACED WITH AN EQUIVALENT PLANT MATERIALS TO ENSURE CONTINUED COMPLIANCE WITH LANDSCAPE PLANS.
 - SINCE THE HYDROSEED MIX IS NATIVE, IRRIGATION SHALL BE APPLIED ONLY AS NECESSARY TO PROMOTE THE GERMINATION AND EARLY GROWTH OF THE PLANTINGS, AND THEREAFTER FOR UP TO 24 MONTHS AFTER SEEDING, ONLY AS REQUIRED TO MAINTAIN THE PLANTINGS IN A HEALTHY CONDITION.
 - LANDSCAPE CONTRACTOR SHALL RECEIVE THE SITE AS IS.
 - THE PLANTING PLANS ARE DIAGRAMMATIC. MINOR ADJUSTMENTS IN PLANT LOCATIONS AND TYPE MAY BE MADE AT THE DISCRETION OF THE LANDSCAPE ARCHITECT.
 - ALL PLANT MATERIAL SHALL BE SUBJECT TO THE APPROVAL OF THE LANDSCAPE ARCHITECT AND REPLACED UPON REQUEST BEFORE OR AFTER THE PLANTING.
 - LANDSCAPE ARCHITECT SHALL APPROVE FINAL PLACEMENT OF ALL SHRUBS PRIOR TO PLANTING.
 - 1 GAL. SHRUB PITS SHALL BE TWO TIMES ROOTBALL DIAMETER WIDE AND 1-1/2 TIMES CONTAINER DEPTH.
 - DO NOT DAMAGE PLANT ROOTBALL DURING TRANSPORTATION OR PLANTING.
 - NITROLOGIC ORGANIC AMENDMENT SHALL BE WILBUR-ELLIS WIL-GRO™ SOIL AMENDMENT, LOAMEX™, OR APPROVED EQUAL.
 - A PLANTING BACKFILL MIX FOR ALL CONTAINER PLANTS SHALL CONSIST OF 1/2 NITROLOGIC ORGANIC AMENDMENT AND 45% EXISTING SOIL, PLUS 2 LBS. PER CU. YD. OF SOIL SULFUR, 1/2 LBS. OF IRON SULFATE, 4 LBS. OF TRIC ORGANIC FERTILIZER 5-2-4 PER CUBIC YARD. IN ADDITION APPLY 1/2 LBS. OF TRIC WOOD DRENCH FOR THE TOTAL OF BACKFILL OR PER MFG'S SPECIFICATIONS.
 - ALL PLANTED AREAS SHALL BE WATERED IN THOROUGHLY WITH SARVON™ PER MANUFACTURER'S SPECIFICATION IN ADVANCE OF PLANTING. ALL PLANTS SHALL BE WATERED THOROUGHLY WITH SUPERTHRIVE™ WITHIN 2 HOURS OF PLANTING.
 - ALL PLANTS 1-GALLON SIZE OR LARGER SHALL RECEIVE AGRIFORM 21-GRAM 20-10-5 FERTILIZER TABLETS AT THE FOLLOWING RATES:
1-GALLON ONE, TWO PER 5-GALLON; PLACE TABLETS AT HALF THE DEPTH OF THE PLANTING PIT AND 1" FROM ROOTBALL.
 - ALL PLANTS PLANTED FROM CONTAINERS SHALL HAVE THEIR ROOTBALLS SCORED WITH A SHARP TOOL TO A DEPTH OF 1" IN THREE LONGITUDINAL INCISIONS AT LOCATIONS SPACED AROUND THE ROOTBALL BEFORE PLACING PLANT IN PLANTING HOLE.
 - ALL SHRUB BASINS (ONLY) SHALL BE COVERED WITH A 1" DEEP LAYER OF A HIGH QUALITY MULCH (BAGGED PRODUCT). ALL BARK TO BE NITROLOGIZED WITH 5% NITROGEN.
 - A LANDSCAPE MAINTENANCE PERIOD OF 1 YEAR SHALL BE CONSIDERED PART OF THIS CONTRACT. PLEASE BID AS A SEPARATE ITEM.

HYDROSEEDING SPECIFICATIONS

- SUPERVISION: ALL HYDROSEEDING IS SUBJECT TO APPROVAL BY THE LANDSCAPE ARCHITECT OR HIS REPRESENTATIVE, AND THEY SHALL, IF NECESSARY, BE RELOCATED AS DIRECTED AS PART OF THE CONTRACT. THE LANDSCAPE ARCHITECT OR HIS REPRESENTATIVE SHALL SUPERVISE THE HYDROSEEDING.
- HYDROSEED APPLICATION: A SLURRY OF FERTILIZER, SEED, AND WOOD PULP OR FIBER SHALL BE AGITATED TO PROVIDE A UNIFORM MIX. THE OPERATOR SHALL SPRAY THE AREA WITH A COMPLETE UNIFORM VISIBLE COAT USING THE COLOR OF THE CELLULOSE FIBER AS A VISUAL GUIDE. THE SLURRY SHALL BE APPLIED IN A DOWNWARD DRIBBLING MOTION (EXCEPT ON SLOPES WELL ABOVE THE OPERATOR) VIA A FAN STREAM NOZZLE. THE MATERIALS SHOULD BE UNIFORMLY IMPREGNATED WITH SEED AND SHALL ALLOW PENETRATION OF RAINFALL AND PERCOLATION OF MOISTURE INTO THE UNDERLYING SOIL.
- THE HYDROMULCHING SLURRY COMPONENTS SHALL NOT BE LEFT IN THE HYDROMULCH MACHINE FOR MORE THAN TWO HOURS. IF SLURRY COMPONENTS ARE LEFT FOR MORE THAN TWO HOURS IN THE MACHINE, THE CONTRACTOR SHALL ADD 50% MORE OF THE ORIGINALLY SPECIFIED SEED MIX TO ANY SLURRY MIX WHICH HAS NOT BEEN APPLIED WITHIN THE TWO HOURS AFTER MIXING. THE CONTRACTOR SHALL ADD 15% MORE OF THE ORIGINAL SEED MIX TO ANY SLURRY MIXTURE WHICH HAS NOT BEEN APPLIED EIGHT HOURS AFTER MIXING. ANY MIXTURE WHICH HAS NOT BEEN APPLIED WITHIN 8 HOURS OF MIXING SHALL BE REJECTED AND DISPOSED OF OFF-SITE AT CONTRACTOR'S EXPENSE.
- SPECIAL CARE IS TO BE EXERCISED BY THE CONTRACTOR TO PREVENT THE SLURRY FROM BEING SPRAYED ON TO ANY ADJACENT PLANTERS, PROPERTY, OR ON TOWLS OR WALLS. ANY SLURRY SPRAYED ON THESE AREAS SHOULD BE CLEANED OFF BY THE CONTRACTOR.
- GERMINATION STAGE IRRIGATION: WITHIN 12 HOURS AFTER HYDROMULCHING THE PLANTING AREAS, THE WATERING SEQUENCE SHOULD BE INITIATED. THE WATER SHOULD BE LEFT ON LONG ENOUGH TO MOISTEN THE SOIL THOROUGHLY TO THE DEPTH OF THE SLURRY MULCH, TAKING CARE NOT TO SUPER SATURATE OR WASH AWAY THE SLURRY AND SEED. THE CONTRACTOR WILL REPAIR ALL SEED WASHING OR EROSION. A LIGHT, FREQUENT IRRIGATION SEQUENCE SHOULD CONTINUE UNTIL THE SEEDLINGS HAVE GROWN BEYOND THE GERMINATION STAGE. THE GERMINATION STAGE WILL RANGE FROM 45 TO 60 DAYS.
- PREPLANTING FERTILIZER MAY BE APPLIED WITH THE HYDROSEED. FERTILIZER SHALL BE AN ORGANIC, PELLETTED OR CHIP TYPE, UNIFORM IN COMPOSITION, FREE-FLOWING, SUITABLE FOR APPLICATION WITH APPROVED EQUIPMENT, AND DELIVERED TO THE SITE IN UNOPENED, ORIGINAL CONTAINERS, EACH BEARING THE MANUFACTURER'S STATEMENT OF GUARANTEED ANALYSIS. FERTILIZERS SHALL BE AT RATES RECOMMENDED BY AGRICULTURAL SUITABILITY SOIL TESTING RESULTS OR THE LANDSCAPE ARCHITECT.
- GUARANTEE: ALL HYDROSEEDING SHALL BE GUARANTEED BY THE CONTRACTOR AS TO GROWTH AND HEALTH FOR A PERIOD OF THIRTY (30) DAYS AFTER FINAL ACCEPTANCE BY THE LANDSCAPE ARCHITECT. AREAS THAT FAIL TO GROW SHALL BE RESEEDED UPON DIRECTION OF THE LANDSCAPE ARCHITECT. THE CONTRACTOR IS SUBJECT TO A SIXTY (60) DAY MAINTENANCE PERIOD OF THE RESEEDED AREAS.

AS A FIRST ITEM OF WORK CONTRACTOR SHALL PROVIDE THE LANDSCAPE ARCHITECT WITH A COMPOSITE SOIL SAMPLE, COLLECTED AT THE DIRECTION OF THE LANDSCAPE ARCHITECT, OF FOUR (4) EQUAL AMOUNTS, FROM A MINIMUM OF 6 LOCATIONS ON THE PROJECT SITE. SOIL SAMPLE WILL BE PROCESSED BY THE LANDSCAPE ARCHITECT. ACTUAL SOIL AMENDMENTS WILL BE BASED ON THE RESULTS OF THE LAB TEST OF THIS SAMPLE. THE AMENDMENT SPECIFICATIONS HAVE BEEN CONSTRUCTED SO AS TO COVER MOST CONTINGENCIES FOR AMENDMENT, THEREBY ELIMINATING THE POSSIBILITY OF A CHANGE IN COST.

NOTES:
-THE NATIVE NON-IRRIGATED HYDROSEED MIX SHALL BE APPLIED TO THE SLOPE BETWEEN OCTOBER 15 AND JANUARY 15 TO PROMOTE NATURAL GERMINATION AND EARLY GROWTH OF THE PLANTINGS WITHIN THE MONTHS WITH MORE PRECIPITATION.
-PRIOR TO LANDSCAPE CONSTRUCTION, CONTRACTOR SHALL MEET ON-SITE WITH THE LANDSCAPE ARCHITECT TO REVIEW THE SITE CONDITIONS AS GRADED SOILS. SUCCESS CRITERIA AND OTHER REQUIREMENTS OF THE PROJECT.

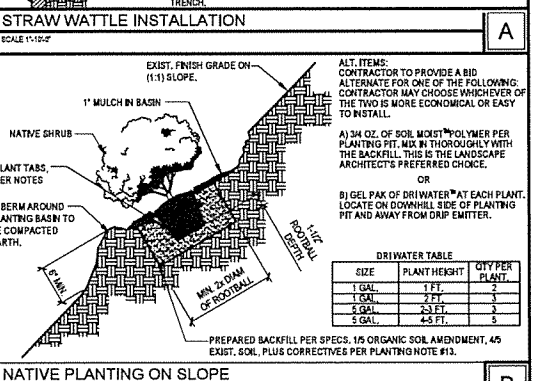
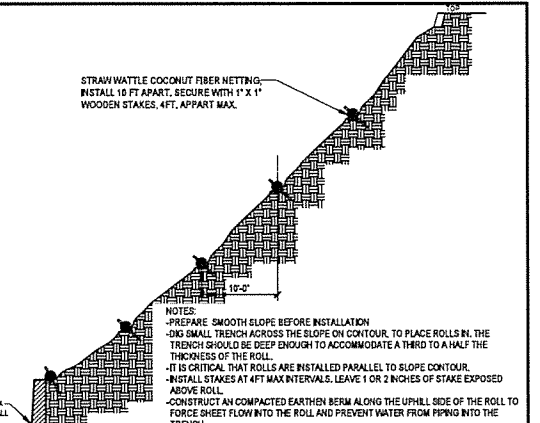

NATIVE CONTAINER PLANTS

ABBR.	SIZE	QTY.	SCIENTIFIC NAME	COMMON NAME
ART. CAL.	1 GAL.	31	ARTEMISIA CALIFORNICA	CALIFORNIA SAGEBRUSH
ATR. BRE.	1 GAL.	40	ATRIPLEX L. BREWERT	BREWERT SALTBUSH
CAM. C.S.	1 GAL.	35	CAMISSONOPSIS CHERANTHIFOLIA	BEACH PRIMROSE
CLE. ISO.	1 GAL.	35	CLEOME ISOMERIS	BLADDER POD
COR. MAR.	1 GAL.	42	COREOPSIS MARITIMA	SEA DAHLIA
ENC. CAL.	1 GAL.	71	ENCELLA CALIFORNICA	CALIFORNIA ENCELLA
ERL. D.P.	1 GAL.	21	ERIOGONUM 'DIANA POINT'	DIANA POINT BUCKWHEAT
(ALT.) ERL. B.D.	1 GAL.	1	ERIOGONUM FASCICULATUM 'BRUCE DICKINSON'	BRUCE DICKINSON BUCKWHEAT
RHU. INT.	1 GAL.	25	RHUS INTEGRIFOLIA	LEMONADE BERRY



BENCH MARK
DESCRIPTION: STD 2-1/2" BRASS DISK S.D. CO. ENGR. STAMPED "LJ 105 1968"
LOCATION: AT SOLANA BEACH, ALONG HWY 101, 0.5 MILE N OF INTERSECTION OF HWY 101 AND VIA LA VALLA; 50 FT E OF CENTERLINE OF HWY 101, 32 FT W OF AT AND SPR TRACKS, 24 FEET N OF PROJECTED CENTERLINE OF DANLA DRIVE, 6 FEET N OF PP, JN120241, A COPPER ROD 13.5 FEET DEEP WITH STANDARD DISK STAMPED LJ 105 1968, T145 R4W 02
ELEV.: 63.78 DATUM: M.S.L.

PLANTING PLAN
SCALE 1"=10'-0"

COASTAL COMMISSION PERMIT NO. CDP 6-99-100

AS Drawn By: ANGELINA SOTELO Date: 12/05/23
R.L.A. 5254 Exp: 12/31/25

RECOMMENDED FOR APPROVAL: By: _____ Date: _____
APPROVED FOR CONSTRUCTION: By: Mohammad Sammak, City Engineer R.C.E. 37146 Exp: 05-30-24

BENCH MARK: SEE DETAILED BLOCK ABOVE LEFT

CITY OF SOLANA BEACH ENGINEERING DEPARTMENT DRAWING NO. L-1
PLANTING PLAN, NOTES & DETAILS FOR: 255, 261, & 265 PACIFIC AVENUE BLUFF VEGETATION
SBGR- SHEET 4 OF 8

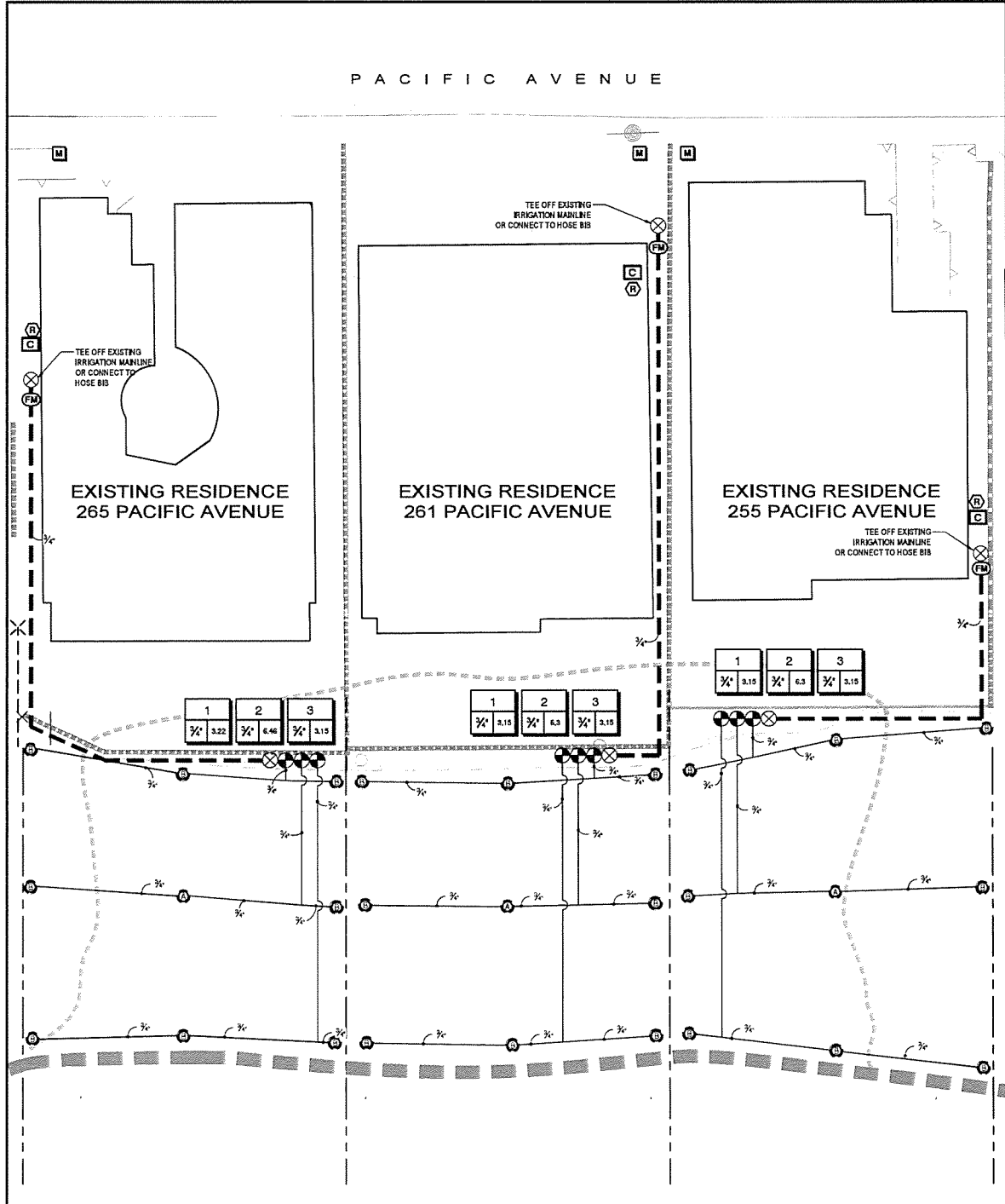

IRRIGATION LEGEND

SYMBOL	MANUFACTURER/MODEL/DESCRIPTION	PSI	GPM	DETAIL
(A)	HUNTER MP3000 PROS-00-PRS30 A ABOVE GRADE SHRUB ROTATOR, FIXED-RISER, PRESSURE REGULATED TO 30 PSI, MP ROTATOR NOZZLE B=BLUE ADJ ARC 90-210, Y=YELLOW ADJ ARC 210-270, A=GRAY 360 ARC.	30	3.15	DETAIL F, SHEET 7
(B)	HUNTER MP3000 PROS-00-PRS30 B ABOVE GRADE SHRUB ROTATOR, FIXED-RISER, PRESSURE REGULATED TO 30 PSI, MP ROTATOR NOZZLE B=BLUE ADJ ARC 90-210, Y=YELLOW ADJ ARC 210-270, A=GRAY 360 ARC.	30	3.15	DETAIL F, SHEET 7
(C)	HUNTER HC-12 12 STATION IRRIGATION CONTROLLER WITH W-FI CONNECTION			DETAIL D, SHEET 7
(D)	HUNTER RFC RAIN AND FREEZE SENSOR, WITH CONDUIT INSTALLATION, MOUNT AS NOTED, NORMALLY CLOSED SWITCH.			DETAIL C, SHEET 7
(E)	HUNTER HC-075-FLOW 3/4\"/>			

IRRIGATION NOTES

- S.C. 1. DUE TO THE SENSITIVE NATURE OF THIS COASTAL BLUFF, TEMPORARY IRRIGATION SHALL BE ACCOMPLISHED BY MANUALLY OPERATED WATERING, AS NECESSARY, UNDER THE SUPERVISION OF THE OWNER'S LANDSCAPE MAINTENANCE CONTRACTOR. HAND WATERING MAY BE ACCOMPLISHED WITH THE USE OF LOW PRECIPITATION RATE (< .5\"/>
- S.C. 2. THIS RECONSTRUCTED BLUFF SHALL HAVE TEMPORARY AND LIMITED IRRIGATION THAT MUST BE REMOVED WITHIN 365 DAYS OF PLANTINGS, UNLESS THE OPINION OF LANDSCAPE ARCHITECT MORE TIME IS REQUIRED.
- S.C. 3. SINCE THE HYDROSEED MIX IS NATIVE, IRRIGATION SHALL BE APPLIED ONLY AS NECESSARY TO PROMOTE THE GERMINATION AND EARLY GROWTH OF THE PLANTINGS, AND THEREAFTER FOR UP TO 26 MONTHS AFTER SEEDING, AND ONLY AS REQUIRED TO MAINTAIN THE PLANTINGS IN A HEALTHY CONDITION.
- S.C. 4. BEFORE THE END OF 6 MONTHS INTO THE LANDSCAPE MAINTENANCE PERIOD, CONTRACTOR TO ADJUST LOCATION OF XERISUE TO AVOID SATURATED ROOT GROWTH.
- S.C. 5. THESE TEMPORARY SYSTEMS SHALL BE DISCONNECTED AND REMOVED WITHIN 26 MONTHS AFTER PLANTING.
- S.C. 6. EXISTING SLOPES ON THIS PROJECT ARE LARGE AND STEEP (MOSTLY 1.5:1 IN STEEPNESS), CONTRACTOR SHALL EXERCISE CAUTION AND SAFETY IN ALL MATTERS PERTAINING TO WORK ON THE SLOPE.
- 1. CONTRACTOR SHALL INSTALL IRRIGATION SYSTEMS THAT ARE COMPLETE AND FUNCTIONING IN EVERY WAY.
- 2. PLANS ARE PRECISE, AND YET DIAGRAMMATIC. PRECISE LOCATION OF EMITTERS SHALL BE FIELD ADJUSTED TO MEET MINOR VARIATIONS IN PLAN.
- 3. CONTRACTOR SHALL CHECK AND VERIFY ALL SITE CONDITIONS, UTILITIES, AND SERVICES PRIOR TO BEGINNING OF WORK.
- 4. CONTRACTOR SHALL CHECK AND VERIFY WATER PRESSURE OF AT LEAST AT 50 PSI AT POINT OF CONNECTION (P.O.C.) PER PLAN, PRIOR TO BEGINNING OF WORK. NOTIFY LANDSCAPE ARCHITECT OF ANY DISCREPANCY.
- 5. POINT OF CONNECTION (P.O.C.) SHALL BE AT EXISTING HOSE BIB AT BACK OF HOUSE. CONTRACTOR TO PROVIDE A NEW VACUUM BREAKER AT EXISTING HOSE BIB FOR THIS PROJECT.
- 6. FLUSH ALL PIPES CLEAN PRIOR TO INSTALLING EMITTERS.
- 7. OBTAIN AN IRRIGATION COVERAGE APPROVAL FROM THE LANDSCAPE ARCHITECT PRIOR TO PLANTING. CONTACT LANDSCAPE ARCHITECT AT LEAST 24 HOURS IN ADVANCE OF DESIRED INSPECTION TIME.
- 8. PROVIDE ANTI-DRAIN VALVES OF CORRECT LINE SIZE WHERE FIELD CONDITIONS DEMAND, PER PLANS, AND/OR AS REQUIRED.
- 9. ALL "DRIP" IRRIGATION DEVICES, SHALL HAVE VALVES THAT SERVICE "DRIP" IRRIGATION AND SHALL BE INSTALLED WITH AN APPROVED FILTER, PER PLAN.
- 10. ALL TRENCHES SHALL BE WETTED AND RECOMPACTED TO 90% MINIMUM UNDER FLATWORK AND 85% IN PLANTING AREAS.
- 11. CONTRACTOR SHALL MOUNT IRRIGATION SCHEDULING GUIDELINES (PROVIDED BY LANDSCAPE ARCHITECT) TO OWNER FOR MANUAL OPERATION. CONTRACTOR IS REQ. TO USE MULTIPLE STARTS FOR EACH VALVE TO ACHIEVE DEEP WATERING.
- 12. "AS-BUILT" DRAWINGS SHALL INCLUDE LOCATIONS OF ALL MAINS, VALVES, & EMITTERS, IF DIFFERENT THAN PLANS. LOCATE BY DIMENSIONING FROM TWO FIXED POINTS (CONTRACTOR MAY USE A BLUEPRINT OF THE SPARKLER PLAN AND EDIT IN PERMANENT RED INK FOR THE AS-BUILT DRAWING).
- 13. PROVIDE THE FOLLOWING TOOLS AND MATERIALS AS PART OF THIS CONTRACT:
 - A. ALL EQUIPMENT OPERATION MANUALS AND GUARANTEES.
 - B. 1 PLASTIC SEALED DIAGRAM OF SYSTEM AREAS. GET REDUCED PRINT FROM LANDSCAPE ARCHITECT.
 - C. 1 AS-BUILT DRAWINGS.

BENCH MARK
 DESCRIPTION: STD 2-1/2" BRASS DISK S.D. CO. ENGR. STAMPED "LJ 105 1968"
 LOCATION: AT SOLANA BEACH, ALONG HWY 101, 0.5 MILE N OF INTERSECTION OF HWY 101 AND VANDERVALE, 50 FT E OF CENTERLINE OF HWY 101, 82 FT W OF AT AND SPRR TRACKS, 24 FEET N OF PROJECTED CENTERLINE OF DANJAN DRIVE, 6 FEET N OF PP JPI25031, A COPPER ROD 13.5 FEET DEEP WITH STANDARD DISK STAMPED LJ 105 1968, T145 R4W 02
 ELEV.: 63.78 DATUM: M.S.L.

IRRIGATION PLAN
 SCALE 1"=10'-0"
 COASTAL COMMISSION PERMIT NO. **CDP 6-99-100**

NOTE: PLAN IS DIAGRAMMATIC. LOCATE MAIN, LATERAL LINE AND VALVES INSIDE PLANTED AREA.



SOLANA BEACH FIRE DEPARTMENT	SANTA FE IRRIGATION DISTRICT	LANDSCAPE ARCHITECT OF WORK	CITY APPROVED CHANGES	APP'D DATE	RECOMMENDED FOR APPROVAL	APPROVED FOR CONSTRUCTION	BENCH MARK	CITY OF SOLANA BEACH	ENGINEERING DEPARTMENT	DRAWING NO. L-3
By: _____ Date: _____ Fire Chief	By: _____ Date: _____ District Engineer	AS Drawn By: ANGELINA SOTELO Date: 12/05/23 R.L.A. 5254 Exp 12/31/25			By: _____ Date: _____	By: Mohammad Sammak, City Engineer R.C.E. 37146 Exp 05-30-24	SEE DETAILED BLOCK ABOVE LEFT	IRRIGATION PLAN, NOTES & DETAILS FOR 255, 261, & 265 PACIFIC AVENUE BLUFF REVEGETATION		SBGR- SHEET 6 OF 8

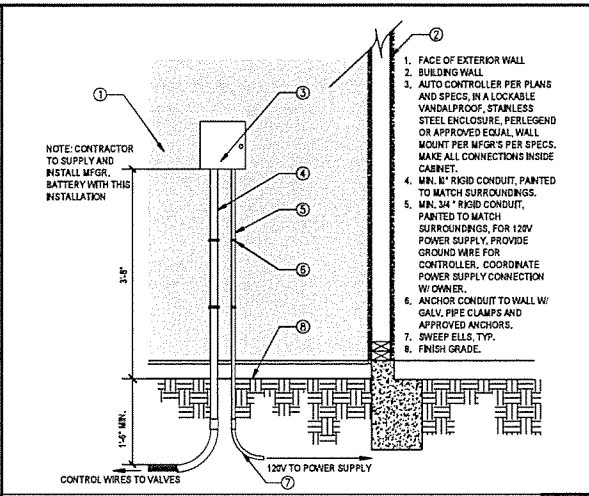

AUTOMATIC CONTROLLER
NOT TO SCALE

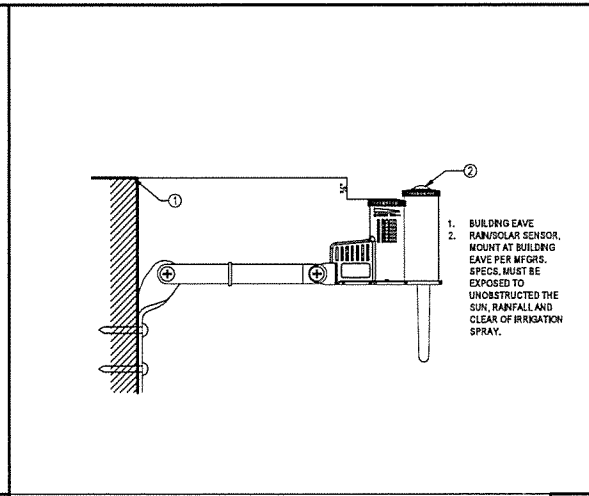

RAIN / SOLAR SENSOR
NOT TO SCALE

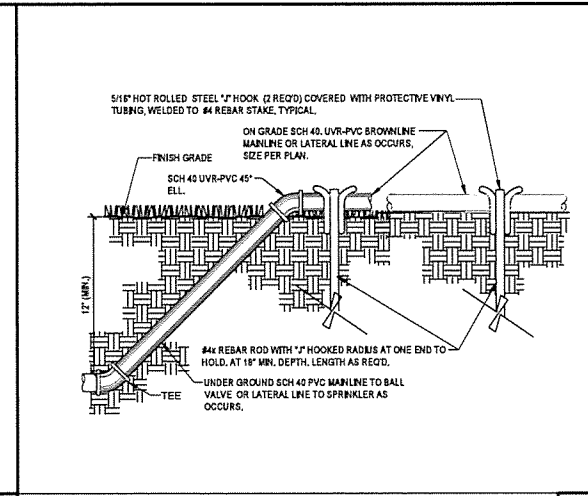

ON GRADE PIPE AND STABILIZER
NOT TO SCALE

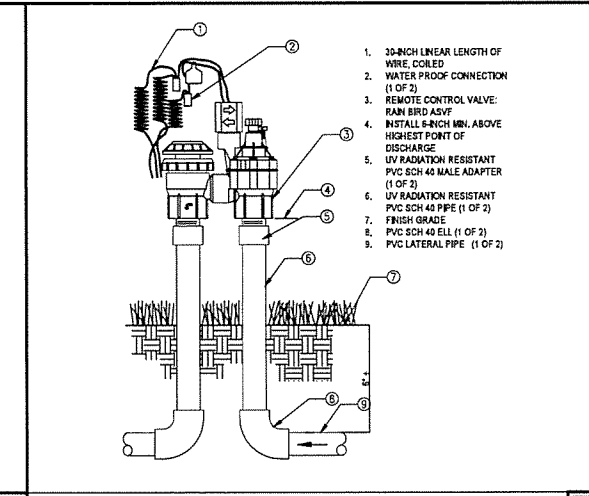

AUTOMATIC ANTI-SIPHON VALVE
NOT TO SCALE

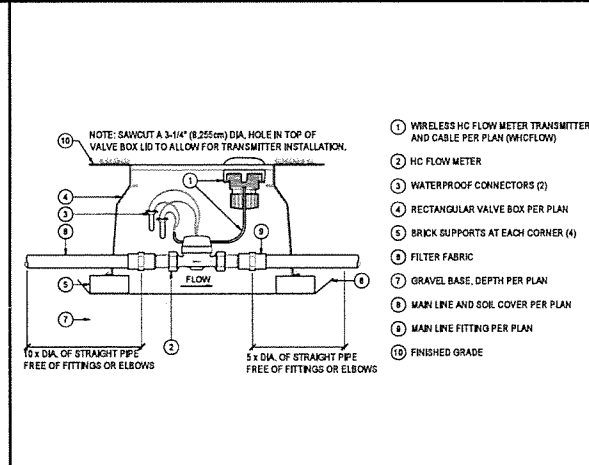

SUB-METER
NOT TO SCALE

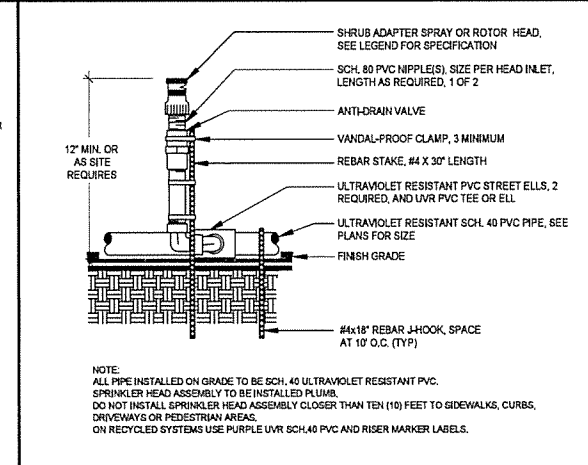

ON-GRADE SPRAY HEADS
NOT TO SCALE

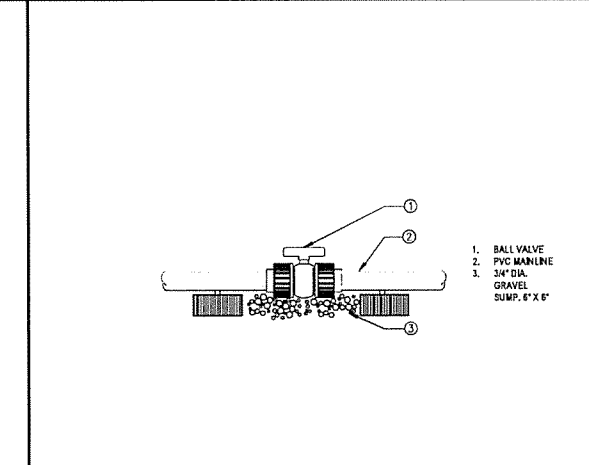

BALL VALVE
NOT TO SCALE

BENCH MARK
DESCRIPTION: STD 2-1/2" BRASS DISK S.D. CO. ENGR. STAMPED "LJ 108 1968"
LOCATION: AT SOLANA BEACH, ALONG HWY 101, 0.5 MILE N OF INTERSECTION OF HWY 101 AND VIAJA VALLE, 55 FT E OF CENTERLINE OF HWY 101, 82 FT W OF AT AND SPRR TRACKS, 24 FEET N OF PROJECTED CENTERLINE OF DANILA DRIVG, 6 FEET N OF PP JP135031, A COPPER ROD 13.5 FEET DEEP WITH STANDARD DISK STAMPED LJ 108 1968, T145 R4W 02
ELEV.: 63.78 DATUM: M.S.L.

COASTAL COMMISSION PERMIT NO. **CDP 6-99-100**

SOLANA BEACH FIRE DEPARTMENT	SANTA FE IRRIGATION DISTRICT	LANDSCAPE ARCHITECT OF WORK	CITY APPROVED CHANGES	APP'D DATE	RECOMMENDED FOR APPROVAL	APPROVED FOR CONSTRUCTION	BENCH MARK	CITY OF SOLANA BEACH	ENGINEERING DEPARTMENT	DRAWING NO. L-4
By: _____ Date: _____	By: _____ Date: _____	AS Drawn By: _____ Date: 12/05/23			By: _____ Date: _____	By: Mohammad Sammak, City Engineer R.C.E. 37146 Exp: 06-30-24	SEE DETAILED BLOCK ABOVE LEFT	IRRIGATION PLAN, NOTES & DETAILS FOR 255, 261, & 265 PACIFIC AVENUE BLUFF REVEGETATION		SBGR- SHEET 7 OF 8



IRRIGATION SPECIFICATIONS

PART 1 - GENERAL

1.01 DESCRIPTION
 A. WORK DISCUSSED IN THIS SECTION INCLUDES THE FURNISHING OF ALL LABOR, MATERIALS, AND EQUIPMENT REQUIRED TO COMPLETE WORK INDICATED ON THE DRAWINGS. THE WORK SHALL BE PERFORMED IN ACCORDANCE WITH THE BEST STANDARDS OF PRACTICE RELATING TO THE VARIOUS TRADES AND UNDER THE CONTINUOUS SUPERVISION OF A COMPETENT FOREMAN, CAPABLE OF INTERPRETING THE DRAWINGS, NOTES, AND THESE SPECIFICATIONS.
 B. IRRIGATION AND LANDSCAPE WORK MAY BE DONE CONCURRENTLY, HOWEVER, PLANTING MAY NOT START IN ANY SECTION PRIOR TO INSPECTION AND APPROVAL OF THE SPRINKLER WORK.
 C. PRIOR TO EXCAVATION FOR IRRIGATION PIPE, LOCATE ALL ELECTRICAL CABLE, CONDUITS, AND ALL UTILITY LINES SO THAT PROPER PRECAUTIONS MAY BE TAKEN NOT TO DAMAGE SUCH IMPROVEMENTS OR EXISTING CONDITIONS. IN THE EVENT OF A CONFLICT BETWEEN SUCH LINES AND PIPE LOCATIONS, PROMPTLY NOTIFY THE OWNER WHO SHALL ARRANGE FOR RELOCATION OF ONE OR THE OTHER. FAILURE TO FOLLOW THIS PROCEDURE PLACES UPON THE CONTRACTOR THE RESPONSIBILITY FOR (AT HIS OWN EXPENSE) MAKING ANY AND ALL REPAIRS FOR DAMAGE RESULTING FOR WORK HEREUNDER.
1.02 SPECIAL CONDITIONS
 THE GENERAL CONDITIONS ARE A PART OF THIS SECTION AND THE CONTRACT FOR THIS WORK, AND APPLY TO THIS SECTION FULLY AS IF REPEATED HERE.
1.03 GENERAL REQUIREMENTS
 FURNISH AND INSTALL IRRIGATION SYSTEM, INCLUDING ANY INCIDENTAL WORK NOT SHOWN OR SPECIFIED WHICH CAN REASONABLY BE INFERRED AS PART OF THE WORK, AS NECESSARY TO PROVIDE A COMPLETE AND WORKABLE SYSTEM.
1.04 WORK INCLUDED
 THE FOLLOWING ITEMS ARE DETERMINED TO BE A PART OF THE IRRIGATION WORK (OR WORK OF LANDSCAPE SUBCONTRACTOR) WHEN APPLICABLE TO THE PLANS.
 A. P.O.C. CONNECTION OF SYSTEM TO EXISTING WATER SUPPLY
 B. REVIEW OF UTILITY PLANS SHOWING OTHER UNDERGROUND FACILITIES.
 C. TRENCHING AND BACKFILL
 D. ALL IRRIGATION MATERIAL AND EQUIPMENT INDICATED ON DRAWINGS.
 E. WATER CONNECTION.
1.05 CODES, RULES, AND SAFETY ORDERS
 ALL WORK AND MATERIALS SHALL BE IN FULL ACCORDANCE WITH THE LATEST RULES AND REGULATIONS OF THE SAFETY ORDERS OF THE DIVISION OF INDUSTRIAL SAFETY, THE UNIFORM PLUMBING CODE PUBLISHED BY THE WESTERN PLUMBING ASSOCIATION, AND OTHER APPLICABLE LAWS OR REGULATIONS. NOTHING IN THESE DRAWINGS OR SPECIFICATIONS IS TO BE CONSTRUED TO PERMIT WORK NOT CONFORMING TO THESE CODES.
1.06 SUBSTITUTIONS AND APPROVAL
 WHEREVER THE TERMS "APPROVE", "APPROVAL", OR "APPROVED EQUAL" ARE USED IN THE PLANS & SPECIFICATIONS, THEY SHALL MEAN THE APPROVAL OF LANDSCAPE ARCHITECT IN WRITING.
1.07 SCHEDULE OF WORK
 SCHEDULE AND COORDINATE HYDROSEEDING AND WATER CONNECTIONS, AND THE PLACEMENT OF MATERIAL AND EQUIPMENT IN A MANNER THAT WILL EFFECT THE EARLIEST COMPLETION OF THE WORK IN CONFORMANCE WITH THE CONSTRUCTION PROGRESS SCHEDULE.

PART 2 - DELIVERY, STORAGE AND HANDLING

2.01 NOTIFICATION
 PROVIDE NOTIFICATION OF DELIVERY SCHEDULE IN ADVANCE SO MATERIAL MAY BE INSPECTED UPON ARRIVAL AT THE JOB SITE. REMOVE UNACCEPTABLE MATERIAL FROM THE JOB SITE IMMEDIATELY.
2.02 PROTECTION
 A. PROTECT WORK AND MATERIALS UNDER THIS SECTION FROM DAMAGE DURING CONSTRUCTION AND STORAGE. POLYVINYL CHLORIDE (PVC) POLYETHYLENE PIPE (PE) AND FITTINGS SHALL BE SHIELDED FROM DIRECT SUNLIGHT.
 B. ASSUME ALL RESPONSIBILITY FOR DAMAGE TO EXISTING CONSTRUCTION AND RESTORE PROPERTY TO ITS ORIGINAL CONDITION SHOULD DAMAGE OCCUR AS A RESULT OF THE WORK OF THIS SECTION.
 C. HANDLE PLASTIC PIPE AND FITTINGS CAREFULLY AND STORE UNDER COVER TO AVOID DAMAGE. BEDS ON WHICH MATERIALS ARE STORED MUST BE FULL LENGTH OF PIPE TO AVOID DAMAGE. ANY PIPE THAT HAS BEEN DAMAGED OR DENTED SHALL NOT BE USED IN THE WORK.

PART 3 - MATERIALS

3.01 GENERAL
 ALL MATERIALS THROUGHOUT THE SYSTEM SHALL BE NEW AND IN PERFECT CONDITION. FOR ALL MATERIALS, AN INVOICE SHALL BE SUBMITTED SHOWING QUANTITIES OF MATERIALS.
3.02 DESCRIPTION
 A. PLASTIC PIPING: ALL MAIN LINE PIPE SHALL BE AN APPROVED BRAND, CLASS 315 PVC. ALL LATERAL PIPE TO SPRINKLERS SHALL BE SCH 40 UHVPVC, TYPE 1120-1220 POLYVINYL CHLORIDE (PVC) PIPE. ALL PIPE SHALL CONFORM TO ASTM D1785 AND ASTM D2241.
 B. PLASTIC FITTINGS AND OTHER PARTS: SCHEDULE 40 POLYVINYL CHLORIDE (PVC) STANDARD WEIGHT, AS MANUFACTURED BY SLOANE, LASC0, OR AN APPROVED EQUAL, ASTM D2464, ASTM D2466, OR ASTM D2467 AS REQUIRED.
 C. SOLVENT CEMENT: COMPATIBLE WITH PVC PIPE AND OF PROPER CONSISTENCY. NO MIXING OF SOLVENT WITH THINNER WILL BE ALLOWED.
 D. PIPE PRIMER, COMPATIBLE WITH PVC PIPE AND OF PROPER CONSISTENCY.
 E. DRIP EMITTERS: OF MANUFACTURERS SPECIFIED IN LEGEND OF DRAWINGS.
 F. FLEXIBLE (BLACK STRIPE) TUBING AND DIGT. TUBING OF THE MANUFACTURE SPECIFIED IN LEGEND ON DRAWINGS. DRIPPER FLOW RATE AND SPACING SHALL BE AS INDICATED ON DRAWINGS.
 1. DRIPLINE FITTINGS: ALL CONNECTIONS SHALL BE MADE WITH DRIPLINE (MANUFACTURE APPROVED) INSERT FITTINGS.
 2. SOIL STAPLES: ALL ON-SURFACE INSTALLATIONS SHALL BE HELD IN PLACE WITH SOIL STAKE DOWNS SPACED EVENLY EVERY 5' ON CENTER, AND WITH TWO STAKE DOWNS ON EACH CHANGE OF LOCATION.
 G. LINE FLUSHING VALVES: OF THE MANUFACTURE SPECIFIED IN LEGEND ON DRAWINGS. ALL DRIPLINE SYSTEMS SHALL BE INSTALLED WITH AN AUTOMATIC LINE FLUSHING VALVES AS INDICATED ON DRAWINGS. DRIPLINE WITH INTEGRATED CHECK VALVES DO NOT REQUIRE AN AUTOMATIC LINE FLUSHING VALVE BUT MUST HAVE A MANUAL FLUSHING PORT(S) IN THE POSITION THAT AN AUTOMATIC FLUSH VALVE WOULD BE POSITIONED.
 H. AIR/VACUUM RELIEF VALVES: OF THE MANUFACTURE SPECIFIED IN LEGEND ON DRAWINGS. EACH INDEPENDENT DRIPLINE SUBSURFACE IRRIGATION ZONE SHALL BE INSTALLED WITH AN AIR/VACUUM RELIEF VALVE AT THE ZONE'S HIGHEST POINT(S). DRIPLINE WITH INTEGRATED CHECK VALVES ZONES DO NOT REQUIRE AN AIR/VACUUM RELIEF VALVE.

PART 4 - INSTALLATION

4.01 LAYOUT
 A. LAYOUT WORK AS ACCURATELY AS POSSIBLE TO THE DRAWINGS. THE DRAWINGS, THOUGH CAREFULLY DRAWN, ARE GENERALLY DIAGRAMMATIC TO THE EXTENT THAT PIPE NOT SHOWN. JOB CONDITIONS WILL NOT ALWAYS PERMIT LOCATING PIPING, VALVES, AND HEADS WHERE SHOWN. WHEN THIS SITUATION OCCURS, IT SHALL BE BROUGHT TO THE OWNER'S ATTENTION IMMEDIATELY AND THE RELOCATION DETERMINED IN A JOINT CONFERENCE. THE CONTRACTOR WILL BE HELD RESPONSIBLE FOR THE RELOCATING OF ANY ITEMS WITHOUT FIRST OBTAINING OWNER'S APPROVAL. HE SHALL REMOVE AND RELOCATE SUCH ITEMS AT HIS OWN EXPENSE IF SO DIRECTED BY THE OWNER.
 B. MINOR CHANGES IN LOCATIONS TO THE ABOVE FROM LOCATIONS SHOWN SHALL BE MADE WHEN DIRECTED BY OWNER AT NO ADDITIONAL COST (TO THE OWNER) PROVIDING SUCH CHANGE IS ORDERED BEFORE SUCH ITEMS OF WORK OR WORK DIRECTLY CONNECTED TO SAME ARE INSTALLED, AND PROVIDING NO ADDITIONAL MATERIALS ARE REQUIRED.
4.02 EXCAVATING AND TRENCHING (NO TRENCHING ON SLOPE)
 A. PRIOR TO EXCAVATION, LOCATE ALL UTILITIES. SEE NOTE 1.01 C AT THE BEGINNING OF THIS SECTION. PERFORM ALL EXCAVATIONS AS REQUIRED FOR THE INSTALLATION OF THE WORK INCLUDED UNDER THIS SECTION, INCLUDING SHORING OF EARTH BANKS TO PREVENT CAVE-INS. RESTORE ALL SURFACES, EXISTING UNDERGROUND INSTALLATIONS, ETC., DAMAGED OR CUT AS A RESULT OF THE EXCAVATIONS, TO THEIR ORIGINAL CONDITION AND IN A MANNER APPROVED BY OWNER.
 B. ALL TRENCHES SHALL BE A MINIMUM OF 6 INCHES FROM PAVING, TRENCHING ADJACENT TO STRUCTURES SHALL BE CLEARLY OUTSIDE THE ANGLE OF INFLUENCE OF FOOTINGS (A HORIZONTAL DISTANCE TWICE THE DEPTH FROM FINISHED GRADE TO THE TOP ONE THIRD OF THE FOOTING).
 C. TRENCHES SHALL BE MADE WIDE ENOUGH TO ALLOW A MINIMUM OF 4 INCHES BETWEEN PARALLEL PIPE LINES. MAINTAIN A MINIMUM OF 1 INCH VERTICAL CLEARANCE BETWEEN LINES. TRENCHES FOR PIPE LINES SHALL BE MADE OF SUFFICIENT DEPTHS TO PROVIDE THE MINIMUM COVER FROM FINISH GRADE OF 12-INCH MINIMUM COVER OVER LATERAL LINES TO HEADS.
 1. 18-INCH MINIMUM COVER OVER MAINLINES TO REMOTE CONTROL VALVES.
 2. 12-INCH MINIMUM COVER OVER LATERAL LINES TO HEADS.
 D. MAINTAIN ALL WARNING SIGNS, SHORING, BARRICADES, FLARES, AND RED SIGNAL LANTERNS AS REQUIRED BY THE SAFETY ORDERS OF THE DIVISION OF INDUSTRIAL SAFETY AND ANY LOCAL ORDINANCES.
4.03 PIPE LINE ASSEMBLY
 A. BACKFLOW PREVENTER: INSTALL 12-INCH MINIMUM ABOVE GRADE WITH CONCRETE THRUST BLOCKS.
 B. REMOTE CONTROL VALVES: INSTALL WHERE SHOWN. GROUP TOGETHER WHERE PRACTICAL. PLACE NO CLOSER THAN 3 INCHES AND PARALLEL TO PAVING, AND HOUSE IN VALVE BOXES WITH TOPS SET TO GRADE.
 C. PLASTIC PIPE AND FITTINGS: PIPE MAY BE ASSEMBLED AND WELDED ON THE SURFACE. SNAKE PIPE FROM SIDE TO SIDE OF TRENCH BOTTOM TO ALLOW FOR EXPANSION AND CONTRACTION. SOLVENT-WELD PLASTIC PIPE AND FITTINGS, USING SOLVENTS AND METHODS AS RECOMMENDED BY MANUFACTURER OF THE PIPE, EXCEPT WHERE SCREWED CONNECTIONS ARE REQUIRED. PIPE AND FITTINGS SHALL BE THOROUGHLY CLEANED OF DIRT, DUST, AND MOISTURE BEFORE APPLYING SOLVENT. INSTALL PIPE AT TEMPERATURES OVER 40 DEGREES F.
 IMPORTANT! - CLEAN OFF EXCESS SOLVENT. ALL WELDED JOINTS SHALL CURE AT LEAST 15 MINUTES BEFORE MOVING OR HANDLING, AND AT LEAST 24 HOURS BEFORE WATER IS PERMITTED IN THE PIPE.
 D. PLASTIC TO METAL PIPE CONNECTIONS: MAKE ALL CONNECTIONS BETWEEN PLASTIC PIPE AND METAL PARTS OR PIPE WITH THREADED FITTINGS USING PLASTIC MALE ADAPTERS. APPLY A NON-HARDENING PIPE DOPE OR TEFLON TAPE TO MALE THREADS. TAKE UP WITH LIGHT WRENCH PRESSURE.
 E. DRIP EMITTERS: INSTALL ON HIGH SIDE OF PLANT BASIN
 F. FLUGGING PIPE: CAP OR PLUG ALL OPENINGS AS SOON AS LINES HAVE BEEN INSTALLED TO PREVENT THE ENTRANCE OF MATERIALS THAT COULD OBSTRUCT THE PIPE, AND LEAVE IN PLACE UNTIL REMOVAL IS NECESSARY FOR COMPLETION OF INSTALLATION.
 G. FLUSHING IRRIGATION SYSTEM: THOROUGHLY FLUSH OUT ALL WATERLINES, THEN INSTALL HEADS, VALVES, AND OTHER HYDRANTS. TEST IN ACCORDANCE WITH THE FOLLOWING GUIDELINES:
 1. REQUEST THE PRESENCE OF OWNER OR HIS REPRESENTATIVE AT LEAST FORTY-EIGHT (48) HOURS IN ADVANCE OF TESTING. TEST IS TO BE ACCOMPLISHED AT THE EXPENSE OF CONTRACTOR, AND IN THE PRESENCE OF THE OWNER OR HIS REPRESENTATIVE IF SO DESIRED, OR WITH SUBMITTAL OF RECORDED RESULTS OF TEST.
 2. CENTER LOAD PIPING WITH SUFFICIENT AMOUNT OF BACKFILL TO PREVENT ARCHING OR SLIPPING UNDER PRESSURE. APPLY CONTINUOUS WATER PRESSURE OF THE NUMBER OF POUNDS PER SQUARE INCH SPECIFIED ON THE PLANS AT THE POINT OF CONNECTION.
 A. PRESSURE LINES TO BE TESTED FOR FOUR HOURS.
 B. LATERAL LINES TO BE TESTED FOR TWO HOURS.
 3. REPAIR LEAKS RESULTING FROM TESTS AND RETEST UNTIL SYSTEM MEETS SPECIFIED TESTS.
 H. DRIPPERLINE INSTALLATION:
 1. INSTALL ALL FLEXIBLE PIPE (BLACK STRIPE) TUBING AS INDICATED ON DRAWINGS. USE ONLY TEFLON TAPE ON ALL THREADED CONNECTIONS.
 2. CLAMP FLEXIBLE PIPE (BLACK STRIPE) TUBING FITTINGS WITH GALVANIZED STAKE DOWN MOD. #TDS-050 W/END BY RAINBRO @ 9 O.C. MAX.
 3. CAP OR PLUG ALL OPENINGS AS SOON AS LINES HAVE BEEN INSTALLED TO PREVENT THE INTRUSION OF MATERIALS THAT WOULD OBSTRUCT THE PIPE. LEAVE IN PLACE UNTIL REMOVAL IS NECESSARY FOR COMPLETION OF INSTALLATION.
 4. THOROUGHLY FLUSH ALL WATER LINES BEFORE INSTALLING VALVES AND OTHER HYDRANTS.
 5. TEST IN ACCORDANCE WITH PARAGRAPH ON HYDROSTATIC TESTS.
 I. UPON COMPLETION OF THE TESTING, THE CONTRACTOR SHALL COMPLETE ASSEMBLY AND ADJUST SPRINKLER HEADS FOR PROPER DISTRIBUTION.

4.04 BACKFILL AND COMPACTING
 A. AFTER SYSTEM IS OPERATING, AND REQUIRED TESTS AND INSPECTIONS HAVE BEEN MADE, BACKFILL EXCAVATIONS AND TRENCHES WITH CLEAN SOIL, FREE FROM RUBBISH.
 B. BACKFILL FOR ALL TRENCHES, REGARDLESS OF THE TYPE OF PIPE COVERED, SHALL BE COMPACTED TO 90% DENSITY.

PART 5 - JOB COMPLETION

5.01 "AS-BUILT" IRRIGATION DRAWINGS
 PREPARE AN "AS-BUILT" DRAWING ON A BLUELINE PRINT WHICH SHALL SHOW DEVIATIONS FROM THE BID DOCUMENTS MADE DURING CONSTRUCTION AFFECTING THE MAIN LINE PIPE, CONTROLLER LOCATIONS, VALVES AND SPRINKLER HEADS. THE DRAWINGS SHALL BE DELIVERED TO OWNER OR HIS REPRESENTATIVE BEFORE FINAL ACCEPTANCE OF WORK. LANDSCAPE CONTRACTOR SHALL KEEP REDLINES AS-BUILTS UP TO DATE IN A DAILY BASIS.
5.02 GUARANTEE
 A. ALL WORK SHALL BE GUARANTEED FOR ONE YEAR FROM DATE OF ACCEPTANCE AGAINST ALL DEFECTS IN MATERIAL, EQUIPMENT, AND WORKMANSHIP. GUARANTEE SHALL ALSO COVER REPAIR OF DAMAGE TO ANY PART OF THE PREMISES, RESULTING FROM LEAKS OR OTHER DEFECTS IN MATERIAL, EQUIPMENT, AND WORKMANSHIP TO THE SATISFACTION OF OWNER OR HIS REPRESENTATIVE.
 B. REPAIRS, IF REQUIRED, SHALL BE DONE PROMPTLY UPON NOTIFICATION BY OWNER OR HIS REPRESENTATIVE AT NO ADDITIONAL COST.
 C. MAINTENANCE DATA: SUBMIT MAINTENANCE DATA AND PARTS LISTS FOR IRRIGATION SYSTEM MATERIALS AND PRODUCTS. INCLUDE THESE DATA, PRODUCT DATA, SHOP DRAWINGS AND RECORD DRAWINGS IN MAINTENANCE MANUAL.

BENCH MARK	
DESCRIPTION:	STD 2-1/2" BRASS DISK S.D. CO. ENGR. ETAMPED "LJ 108 1868"
LOCATION:	AT SOLANA BEACH, ALONG HWY 101, 0.5 MILE N OF INTERSECTION OF HWY 101 AND WALA VALLE, 50 FT E OF CENTERLINE OF HWY 101, 82 FT W OF AT AND BFR TRACKS, 24 FEET N OF PROJECTED CENTERLINE OF DANILA DRIVE, 6 FEET N OF PP, JPI 10041, A COPPER ROD 13.5 FEET DEEP WITH STANDARD DISK STAMPED LJ 108 1958, T145 R4W 02
ELEV.:	63.78 DATUM: M.S.L.

COASTAL COMMISSION PERMIT NO. **CDP 6-99-100**

SOLANA BEACH FIRE DEPARTMENT		SANTA FE IRRIGATION DISTRICT		LANDSCAPE ARCHITECT OF WORK		CITY APPROVED CHANGES		APP'D	DATE	RECOMMENDED FOR APPROVAL	APPROVED FOR CONSTRUCTION	BENCH MARK	CITY OF SOLANA BEACH	ENGINEERING DEPARTMENT	DRAWING NO. L-5
By: _____ Fire Chief	Date: _____	By: _____ District Engineer	Date: _____	AS Drawn By: _____ R.L.A. 5254	Date: 12/05/23 Exp: 12/31/25					By: _____ Date: _____	By: _____ Date: _____ Mohammad Sammak, City Engineer R.C.E. 37148 Exp 05-30-24	SEE DETAILED BLOCK ABOVE LEFT	255, 261, & 265 PACIFIC AVENUE BLUFF REVEGETATION		SHEET 8 OF 8



T18312



March 7, 2024

UES Job No. 4830.2400020

City of Solana Beach
635 South Highway 101
Solana Beach, California 92075

Attention: Ms. Corey Andrews
(858) 720-2434
candrews@cosb.org

Subject: Application Submittal Geotechnical Review
255 – 265 Pacific Avenue (Alamo)
Solana Beach, California

References: At End of Document

Ms. Andrews:

As requested, Universal Engineering Sciences (UES) has reviewed the provided submittal application documents referenced at the end of this letter. The purpose of our review was to assess whether the proposed project is in substantial compliance with the City of Solana Beach's (City) Local Coastal Plan (LCP) policies.

The proposed construction consists of repairs to deep erosional gullies formed within an existing permitted upper bluff retention device (i.e., geogrid reinforced upper slope), and no repairs or alterations to the lower bluff seawall are proposed. The proposed repairs are described as infilling, with geogrid reinforcement, of deep erosional gullies that have formed over time. The proposed repairs appear to restore the upper bluff to its previously permitted condition.

Based on UES's review, the proposed upper bluff repairs described herein appear to substantially conform to the City's referenced Local Coastal Plan (LCP). Specifically, the proposed upper bluff repairs appear to be in substantial conformance with LCP Policy 4.54, which states that "Any bluff retention device shall be reasonably maintained and repaired by the bluff property owner on an as-needed basis...".

UES's review is based on the referenced and provided submittal documents. If the proposed improvements or referenced documents are revised or updated, or new documents are provided, they should be provided to UES for additional review and comment, as warranted.

We appreciate this opportunity to be of service on this project. If you have any questions regarding this report, please do not hesitate to contact the undersigned.

Respectfully submitted,

UNIVERSAL ENGINEERING SCIENCES (UES)

A handwritten signature in blue ink, appearing to read "C. Kenny", written in a cursive style.

Colm J. Kenny, GE #3201
Senior Engineer



REVIEWED DOCUMENTS:

Grading Plans

255, 261 & 265 Pacific Avenue Bluff Revegetation
Solana Beach, California 92075
Prepared by Engeo, Dated November 16, 2023

Seawall Monitoring Report

California Coastal Commission; CDP No. 6-99-100 (249-11 Pacific Avenue and CDP No. 6-13-0437
249 Pacific Avenue Seawall Extension
Prepared by Engeo, Dated August 17, 2023

City of Solana Beach Local Coastal Plan

Adopted February 27th, 2013, As Amended November 2018

Solana Beach Resolution No. 98-101

Applicant Buzz and Diana Colton, Case 17-98-25
Dated November 9, 1998



STAFF REPORT CITY OF SOLANA BEACH

TO: Honorable Mayor and City Councilmembers
FROM: Alyssa Muto, City Manager
MEETING DATE: May 22, 2024
ORIGINATING DEPT: Engineering Department
SUBJECT: **Public Hearing: City Council Consideration of Resolution 2024-042 Adopting the Regional Transportation Improvement Program (RTIP) for Fiscal Years 2025 through 2029**

BACKGROUND:

The San Diego Association of Governments (SANDAG) is required by State and Federal laws to develop and adopt a Regional Transportation Improvement Program (RTIP) every two years. The RTIP is a multi-year program of proposed major highway, arterial, transit, and bikeway projects including the *TransNet* Program of Projects. The current 2023 RTIP was adopted by the SANDAG Board on September 23, 2022, and covers the five-year fiscal period 2022/23 through 2026/27. The RTIP includes projects funded by the 2004 Proposition A (*TransNet* Extension). The 2023 RTIP can be downloaded at the following SANDAG website:

<https://www.sandag.org/-/media/SANDAG/Documents/PDF/funding/funding-and-programming/regional-transportation-improvement-program/final-2023-rtip-2022-11-30.pdf>

To meet the requirements of the *TransNet* Extension Ordinance, SANDAG will develop the 2025 RTIP covering the five-year period from FY 2024/25 through FY 2028/29. It is anticipated that the 2025 RTIP will be presented for adoption to the SANDAG Board in September 2024.

This item is before the City Council for the consideration of Resolution 2024-042 (Attachment 1) approving the five-year 2025 Regional Transportation Improvement Program for Fiscal Years (FY) 2024/25 through FY 2028/29.

CITY COUNCIL ACTION:

DISCUSSION:

The RTIP is a planning document that lists all major transportation improvement projects for the region. A transportation project generally has to be listed on the RTIP in order to be eligible for *TransNet*, State or Federal funding. The RTIP for San Diego County is prepared by SANDAG. SANDAG prepares a five-year program and updates this program every two years with input provided from local agencies in the county.

SANDAG requires local agencies to submit a separate project submittal form for each project that is to be included in the RTIP. The submittal of the projects to SANDAG must include evidence of formal action by the legislative body of the City, preferably by resolution. SANDAG also requires that the local agency hold a public hearing prior to adoption of the 2025 RTIP. After all public agencies in the region submit a resolution to SANDAG approving their portion of the RTIP, SANDAG will then adopt the 2025 RTIP for the entire region. It is anticipated that SANDAG will adopt the RTIP in September 2025.

The City has advertised a public hearing for May 22, 2024 to receive public input with regards to the 2025 RTIP. SANDAG recently provided a five-year forecast projecting that the City will receive the following amounts in *TransNet* revenues:

FY 2024-25	FY 2025-26	FY 2026-27	FY 2027-28	FY 2028-29
\$244,000	\$250,000	\$257,000	\$272,000	\$286,000

The above amounts exclude debt service payments for the Highway 101 Westside Improvements.

For the 2025 RTIP, Attachment 2 lists five projects to be carried over from the 2023 RTIP: 1) Pavement Resurfacing, 2) Pavement Maintenance, 3) Sidewalks and associated street improvements, 4) Lomas Santa Fe Drive Improvements, and 5) Traffic Signal Upgrades. Attachment 2 details the proposed funding program for the upcoming years for the carried over projects. While no new projects are proposed as part of the adoption, the City may add or modify projects through the quarterly amendment process.

CEQA COMPLIANCE STATEMENT:

Adoption of the RTIP is not a project under CEQA. Environmental review will be addressed prior to City Council approval to advertise construction bids for each project.

FISCAL IMPACT:

Adopting the RTIP will allow the City to receive *TransNet* funding. There is no fiscal impact currently.

WORK PLAN:

While the RTIP is not specifically included in the Work Plan, the projects programmed in the RTIP are included in the Work Plan.

OPTIONS:

- Adopt Staff recommendation.
- Deny Staff recommendation.
- Provide direction to Staff.

DEPARTMENT RECOMMENDATION:

Staff recommends that the City Council:

1. Conduct the Public Hearing: Open the public hearing, Report Council disclosures, Receive public testimony, and Close the public hearing.
2. Consider Adoption of Resolution 2024-042, approving the 2025 Regional Transportation Improvement Program for Fiscal Years (FY) 2024/25 through FY 2028/29.

CITY MANAGER'S RECOMMENDATION:

Approve Department Recommendation.



Alyssa Muto, City Manager

Attachments:

1. Resolution 2024-042
2. 2025 RTIP Projects List



STAFF REPORT

CITY OF SOLANA BEACH

TO: Honorable Mayor and City Councilmembers
FROM: Alyssa Muto, City Manager
MEETING DATE: May 22, 2024
ORIGINATING DEPT: Engineering Department
SUBJECT: **Update on Potential Sidewalk Improvements Along
Glencrest Drive from Lomas Santa Fe Drive to Dell Street**

BACKGROUND:

Construction of sidewalks along both sides of Glencrest Drive from Lomas Santa Fe Drive to Dell Street (Project) has been identified as a high priority project for consideration. This potential project is a priority as it is identified in the City's Comprehensive Active Transportation Strategies (CATS) as well as the City's Safe Routes to School (SRTS) programs.

This item is before the City Council to provide an update on this potential project, and to receive feedback and direction for possible implementation.

DISCUSSION:

Glencrest Drive is a local street serving many residents not just for vehicular traffic but also for walking and biking. Historically, many residents expressed concerns about traffic speeds along Glencrest Drive. City Staff, in collaboration with and in response to concerns raised by residents, implemented traffic calming measures such as creative striping, installation of speed cushions, and placement of electronic speed limit signs to make the road safer and more user friendly for all modes of transportation. While these measures were relatively successful, residents, particularly parents of Skyline and Earl Warren school students, are still concerned about the lack of a separate sidewalk facility. The subject segment of the road (Glencrest Drive, between Lomas Santa Fe Drive and Dell Street) is used by many local students and their parents as one of the primary paths of travel to and from Skyline and Earl Warren schools. It is important to note that, during the preparation of the City's Safe Routes To School Program, many parents of students recommended sidewalks within the study area.

COUNCIL ACTION:

Construction of a sidewalk will impact 20 homes along the study area, nine homes on the east side and 11 homes on the west side. In general, the homes along the east side of the study area are either at or slightly below the street grade. The homes on the west side are slightly or significantly above the street grade. Some homes have two driveways, similar to a horseshoe design, and all homes have private improvements encroaching well into the public right of way.

The existing improvements within the right of way consist of two 11-foot wide lanes, two 6-foot wide paved shoulders and many different types of private improvements beyond the edge of pavement within the 60 foot of right of way. The street fronts for some of the more recently remodeled properties are improved with City Standard 9-inch sloping curb and 10-foot-wide decomposed granite (DG) walking and parking surface. There are many variations of landscaping, hardscaping, and other types of private improvements in the parkway area on both sides. Parking is allowed on both sides of the road and most people park partially on the pavement and partially in the parkway area. As mentioned, pedestrian activities are relatively high in this segment of the road particularly during school time. Pedestrians move on and outside of the paved section of the road, often in between the parked cars depending on availability of space in the right of way.

Staff reached out to a few residents within the study area. Most residents were receptive to the idea of a sidewalk as long as their private improvements are maintained or minimally impacted. Many homeowners requested that the sidewalk to be installed on the opposite side of the road from their properties. Staff mentioned to those residents that were contacted that City Staff would develop plans for the improvements of the sidewalks and would reach out to them again.

The proposed project would construct a concrete curb and sidewalk on both sides of the study area. To avoid acquisition of additional right of way, to maintain the existing private improvements to the extent feasible, and to minimize the cost of construction, the proposed design would result in two 10.5 feet wide lanes and 5-foot-wide sidewalks on both sides. This design would result in 30 on-street parking stalls placed in strategic locations. The driveways would be extended towards the street to provide a better view of the traffic before entering the street. The sidewalks and curbs would meander from extended driveways to inset parking areas. The number of parking spaces for the proposed project is substantially the same as the existing parking spaces. The proposed project would maintain the locations of every existing driveway.

If the proposed project is conceptually acceptable to the City Council, the following tentative steps are recommended for the City Council's consideration:

- Perform a more detailed analysis of the proposed design. Specific attention should be given to the profile of each driveway, walkway, and other existing improvements within the public right of way along each property frontage.
- Conduct community workshop/engagement meeting(s).
- Meet with property owners individually, if requested.
- Complete final Plans Specification, and Estimate (PS&E).

- Advertise for bids.
- Award construction contract by the City Council.
- Start construction.

The proposed design is prepared by in-house City Staff and needs to be further analyzed before any future steps for the project. The objective of this Staff Report is to introduce the project, answer any questions and seek any feedback and recommendations the City Council may have.

CEQA COMPLIANCE STATEMENT:

The project is exempt from the California Environmental Quality Act (CEQA) pursuant to Section 15301(c) of the State CEQA Guidelines.

FISCAL IMPACT:

The construction cost for this project will be prepared when the final design is prepared. The preliminary construction cost is estimated between \$300,000 to \$400,000 depending on many factors such as timing of the construction, number and nature of driveway improvements to be removed and reconstructed. There is \$75,000 allocated for this project in the FY24 CIP in which the full amount is still available.

WORK PLAN:

This project has been added to the draft 2024/25 Work Plan as Community Character Priorities, Item B.22.

OPTIONS:

- Receive report.
- Provide direction to Staff.

DEPARTMENT RECOMMENDATION:

Receive this report and provide direction to Staff.

CITY MANAGER'S RECOMMENDATION:

Approve Department Recommendation.

Alyssa Muto, City Manager